



YAMAHA

**JT1-JT2
SERIES
SERVICE
MANUAL**

NOTICE

This manual has been written by Yamaha Motor Company for use by Authorized Yamaha Dealers and their qualified mechanics. In light of this purpose it has been assumed that certain basic mechanical precepts and procedures inherent to our product are already known and understood by the reader.

Without such basic knowledge, repairs or service to this model may render the machine unsafe, and for this reason we must advise that all repairs and/or service be performed by an Authorized Yamaha dealer who is in possession of the requisite basic product knowledge. Other information is produced by the U. S. distributor, Yamaha International Corporation, and is necessary to provide total technical coverage regarding the product. The Research, Engineering, and Service Departments of Yamaha are continually striving to further improve all models manufactured by the company. Modifications are therefore inevitable and changes in specifications or procedures will be forwarded to all Authorized Yamaha Dealers and will, where applicable, appear in future editions of this manual.

YAMAHA JT SERIES SERVICE MANUAL

1st EDITION, DECEMBER 1973

2nd EDITION, MAY 1976

©DECEMBER 1973 YAMAHA INTERNATIONAL CORPORATION
BUENA PARK, CALIFORNIA 90620

LIT-11612-88-99

FOREWORD

The new YAMAHA MINI ENDURO, though small in size, is a fully functional motorcycle in the Yamaha Enduro vein. The 60cc engine, four speed gearbox, tubular frame and fully functional suspension combine to provide an ideal vehicle for the younger rider.

Its rugged design and excellent performance also make it an intriguing diversion for older, more experienced riders as well.

This service manual has been prepared in order to provide all Yamaha dealers and their service technicians the repair instructions and technical information required to keep the MINI-ENDURO in top condition. We hope that you will find this manual most helpful and valuable in carrying out this goal.

**YAMAHA MOTOR CO., LTD.
ENGINEERING & SERVICE DEPARTMENT**

MODEL IDENTIFICATION

This manual was originally printed for the JT2 Mini-Enduro. It has been edited to include information for the JT1, JT1L and JT2M models.

Generally speaking, there were no major changes to any of the Mini-Enduro models since the JT1 was released for the 1971 model year. The JT1L (1971½ release) was a JT1 with lighting kit. The JT2 had various internal engine changes to improve reliability and carburetor changes to improve performance. JT2 lights were upgraded in intensity. The JT2M was styled after the JT1 for those people who wanted a Mini-motocrosser without lights. Additional identification information is given in the table below.

MODEL	YEAR	IBM ID NUMBER	STARTING ENGINE NUMBER	IDENTIFYING COLOR
JT1	1971	288	JT1-000101	Desert Orange
JT1L	1971 (½)	338	JT1-200101	Desert Orange
JT2	1972	288	JT1-050101	Mandarin Orange
JT2M	1972	288	JT1-300101	Competition Yellow

CONTENTS

CHAPTER 1 GENERAL	1
1- 1 Profile	1
1- 2 Features	2
1- 3 Specifications and Performance	3
1- 4 Performance Curves	5
1- 5 Tools and Instruments for shop service	6
CHAPTER 2 YAMAHA AUTOLUBE	7
2- 1 What is Yamaha Autolube?	7
2- 2 Features of Yamaha Autolube	7
2- 3 Handling the Oil Pump	7
CHAPTER 3 ENGINE	11
3- 1 Engine Removal	11
3- 2 Cylinder Head	15
3- 3 Cylinder	16
3- 4 Piston Pin	17
3- 5 Piston Ring	18
3- 6 Piston	19
3- 7 Flywheel Magneto	20
3- 8 Crankcase Cover (R.H.)	21
3- 9 Clutch	22
3-10 Primary Drive Gear	27
3-11 Kick Starter Mechanism	27
3-12 Shift Mechanism	29
3-13 Rotary Valve	31
3-14 Drive Sprocket	33
3-15 Crankcase	35
3-16 Transmission Assembly	36
3-17 Crankshaft	38
3-18 Bearings and Oil Seals	41
3-19 Carburetor	42

3-20 Air Cleaner	44
CHAPTER 4 CHASSIS	46
4- 1 Front Wheel	46
4- 2 Rear Wheel	49
4- 3 Rear Wheel Sprocket	53
4- 4 Tires and Tubes	54
4- 5 Front Forks	54
4- 6 Rear Shocks	57
4- 7 Gas Tank	58
4- 8 Rear Swing Arm	58
4- 9 Steering Head	60
4- 10 Oil Tank and Tool Box	61
4- 11 Frame	61
4- 12 Handlebars	61
4- 13 Miscellaneous	61
CHAPTER 5 ELECTRICAL SYSTEM	62
5- 1 Electrical Equipment.....	62
5- 2 List of Electrical Components	62
5- 3 Ignition System-Function and Service	63
5- 4 Ignition Timing	63
5- 5 Ignition Coil	64
5- 6 Condenser	64
5- 7 Charging System	65
5- 8 Battery	67
5- 9 Checking the main Switch	69
5- 10 Spark Plug	69
APPENDICES.....	72
I Parts and Service Bulletins	72
II Parts Illustrations	82
III Maintenance and Lubrication Intervals	86
IV Pre-operation Check List	87
Torque Values for Common Components.....	87
V Cleaning and Storage Hints	88
VI Metric Inch Conversion Tables	89

CHAPTER 1 GENERAL

JT1 - JT2M

1-1 Profile

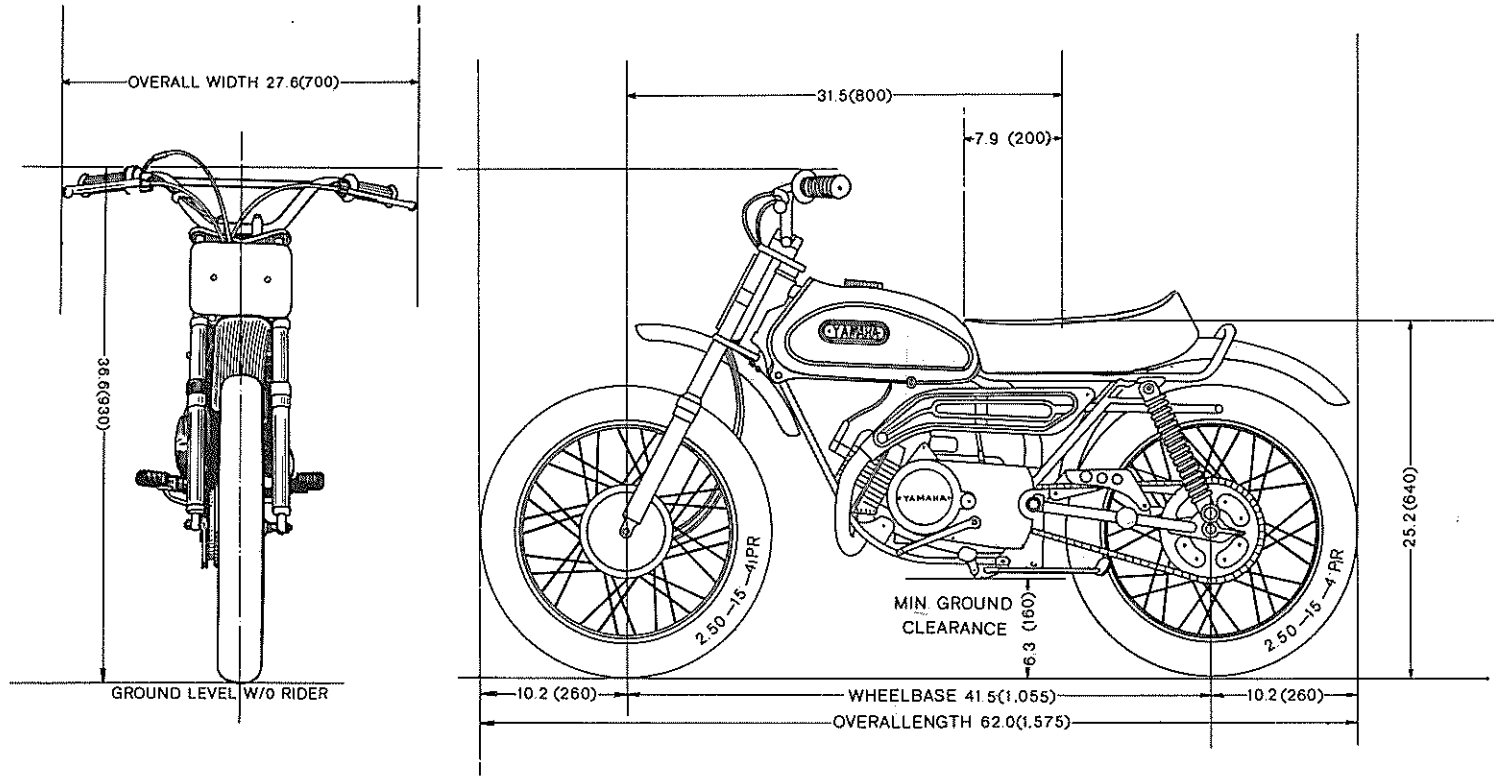

DIMENSIONS/PROFILES TYPICAL FOR ALL MODELS

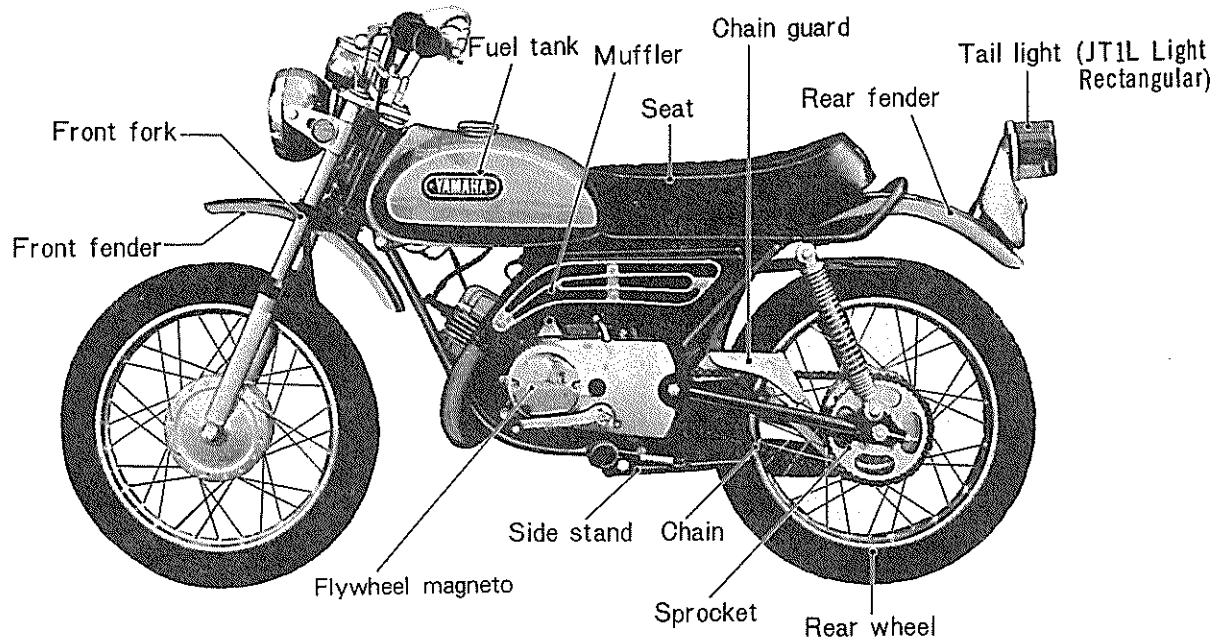

JT1L - JT2

1-3 Specifications & Performance JT2

Model	YAMAHA 60 JT2	<JT1>
Dimensions :		
Overall length	62.4 in (1580 mm)	<62.0>
Overall width	27.6 in (700 mm)	
Overall height	36.6 in (930 mm)	
Wheelbase	41.5 in (1055 mm)	
Min. ground clearance	6.3 in (160 mm)	
Weight : Gross	60 kg	132 lbs
Performance :		
Fuel consumption (on paved level roads)	17.6 mile/gal (19 mph)	
Climbing ability	22 degrees	
Min. turning radius	59.1 in (1500 mm)	
Braking distance	24.6 ft/22 mph (7.5 m/35 km/h)	
Engine :		
Model	JT1	
Type	2 stroke, gasoline	
Lubricating system	Separate lubrication (YAMAHA Autolube)	
Cylinder	Single, forward inclined.	
Displacement	3.54 cu. in (58 cc)	
Bore x Stroke	1.654 in x 1.654 in (42 mm x 42 mm)	
Compression ratio	6.4 : 1	
Max. power	4.5 hp/7,500 r.p.m.	
Max. torque	3.62ft-lb/5,500 r.p.m (0.5 kg-m/5,500 r.p.m)	
Starting system	Kick starter	
Ignition system	Magneto ignition	
Ignition timing	1.8 mm. B.T.D.C.	
Carburetor :		
Type		
M. J.	(See 3-19-C)	
J. N.	Carb. Specs.	
Air cleaner	Wet, foam rubber	
Transmission :		
Clutch	Wet, multiple-disk	
Primary reduction system	Gear	
Primary reduction ratio	3.895 (74/19)	

GENERAL - Specifications and Performance

Model	YAMAHA 60 JT2
Gear box Type Reduction ratio 1st 2nd 3rd 4th Secondary reduction system Secondary reduction ratio Oil capacity	Constant mesh, 4-speed forward 3.077 (40/13) 1.889 (34/18) 1.304 (30/23) 1.038 (27/26) Chain 3.153 (41/13) 0.85 US qts (800-850 cc)
Chassis Frame Suspension system, front Suspension system, rear Cushion system, front Cushion system, rear	Tubular-Double loop Telescopic fork Swinging arm Coil spring, oil damper Coil spring, oil damper
Steering system Steering angle Caster Trail	47° both right and left 63.5° 2.7 in (68mm)
Braking system Type of brake Operation system, front Operation system, rear	Internal expansion Right hand operation Right foot operation
Tire size Front Rear	2.50-15-4PR 2.50-15-4PR
Dynamo Model Manufacturer	F11-L46 <F11-L42> HITACHI Ltd
Tanks Gasoline tank capacity Oil tank capacity	11 U.S. gals (4.3 l) 1.1 U.S. qts (1.0 l)

1-4 PERFORMANCE CURVES

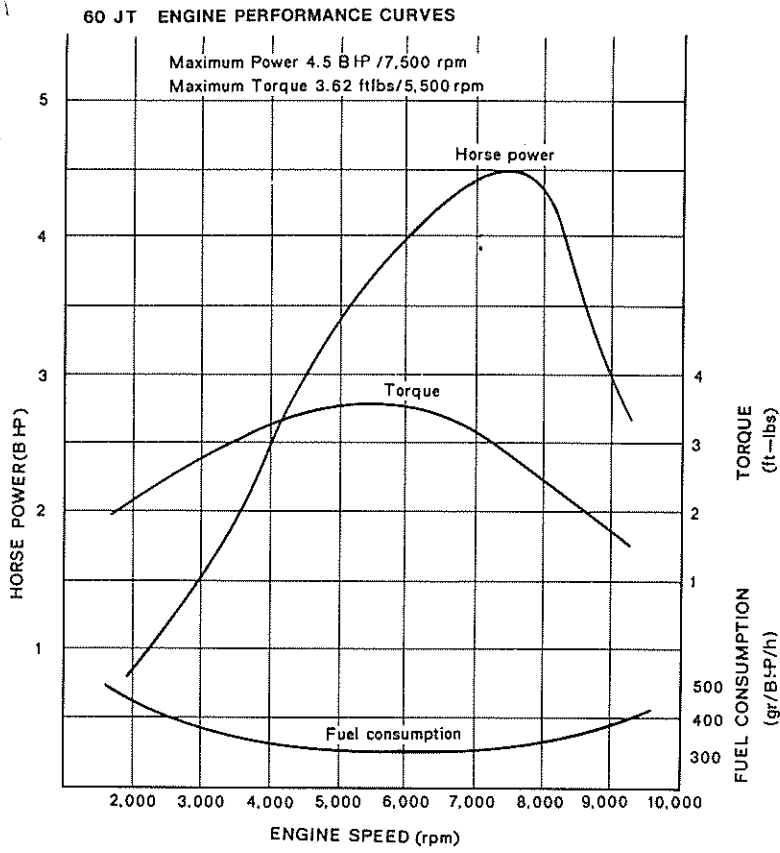

3-port Cylinder Exploded View

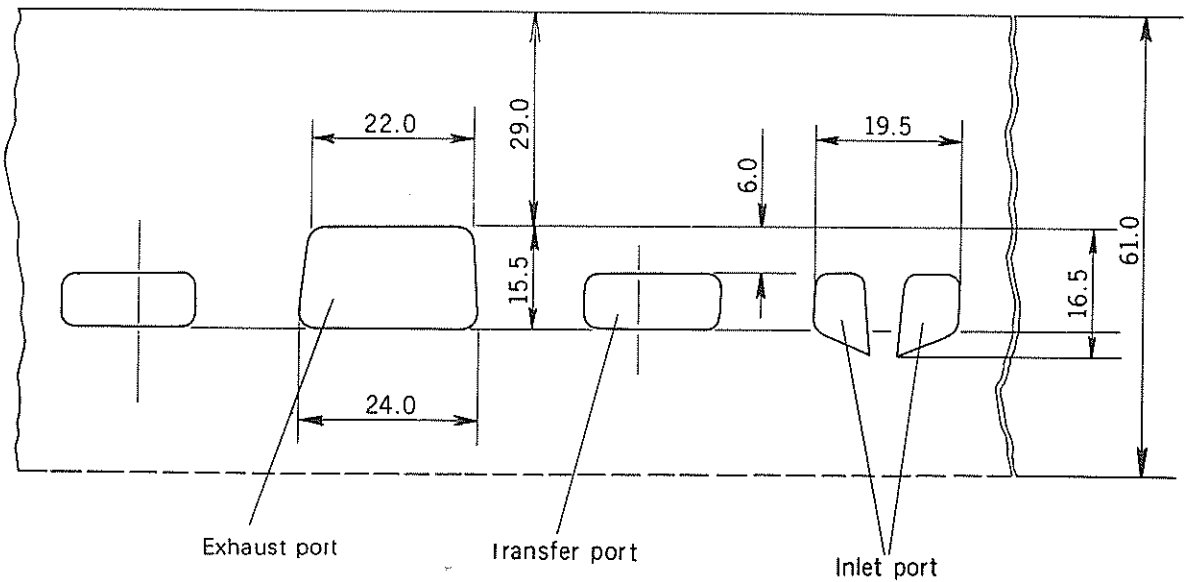

GENERAL - Tools and Instruments for Shop Service

1-6 Tools and Instruments for Shop Service

The following tools and instruments are required to service the JT2

1 General Tools

- 1) Plug wrench 23x29 mm.
- 2) A set of wrenches
- 3) A set of socket wrenches
- 4) Plastic tip hammer
- 5) Steel hammer
- 6) Circlip pliers (ST type)
- 7) Circlip pliers (RT type)
- 8) Needle nose pliers
- 9) Pliers
- 10) Phillips-head screwdriver
- 11) Phillips-head screwdriver (L)
- 12) Phillips-head screwdriver (M)
- 13) Phillips-head screwdriver (S)
- 14) Slot-head screwdriver (M)
- 15) Slot-head screwdriver (S)
- 16) T-handle socket wrench

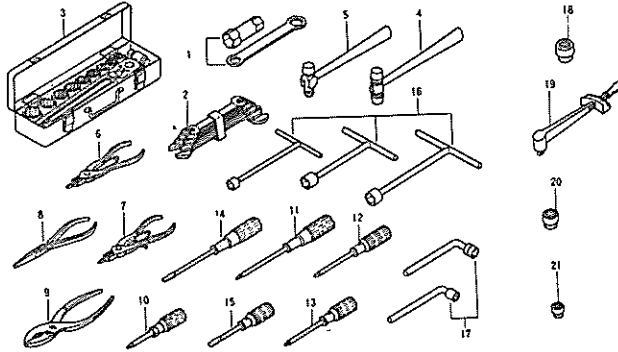

Fig 1-6-1

2 Special Tools and Instruments

- 1 Clutch holding tool
- 2 Crankcase disassembling tool
- 3 Crankshaft assembling tool
- 4 Flywheel magneto holding tool
- 5 Flywheel magneto puller

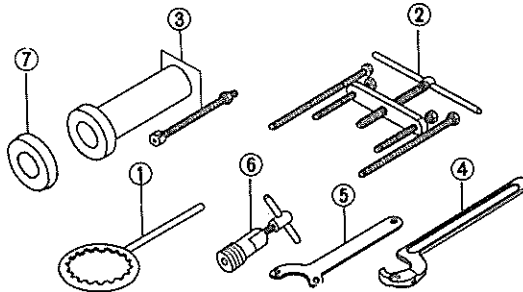

Fig. 1-6-2

In addition an electro-testor, tachometer (engine rpm meter) hydrometer ,etc. should and available.

3 Other Material

- 1) Yamaha Bond (No.5)
- 2) Gear oil
- 3) Grease
- 4) Wiping material
- 5) Yamaha Bond No.4
- 6) Wooden box
- 7) Oiler
- 8) Oil jug



Fig. 1-6-3

The use of a wooden box as shown in the above photo will facilitate engine service and overhaul. Consumable parts (such as gaskets) and replacement parts must also be on hand.

CHAPTER 2 YAMAHA AUTOLUBE (Automatic, Separate Lubrication System)

2-1 What is Yamaha Autolube?

Conventional 2-stroke engines are lubricated by oil pre-mixed in gasoline, but YAMAHA's Autolube furnishes an automatic, separate lubrication system. That is, the oil in a separate oil tank is automatically regulated by the oil pump and fed to the engine according to engine speed and load.

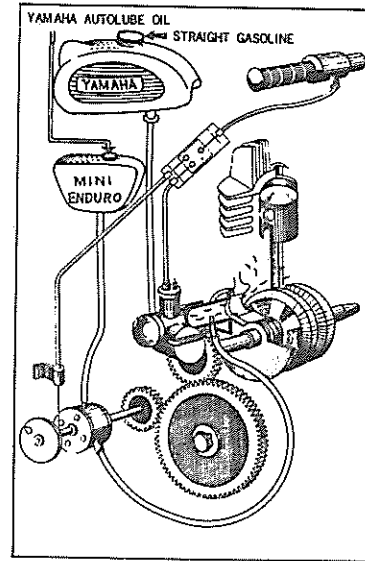

Fig 2-1-1

2-2 Features of Yamaha Autolube

The oil pump is driven by the engine through a reduction gear and is connected to the carburetor throttle cable, which in turn is controlled by the accelerator grip. The oil pump automatically regulates the volume of lubricating oil according to engine speed and throttle valve opening, thus pumping the optimum amount of oil for engine lubrication under any operating condition.

This "automatic, separate lubrication" does not merely eliminate disadvantages in the conventional pre-mix system, but it further improves the performance and efficiency of 2-stroke designs by eliminating certain oil-starvation conditions which formerly existed.

- 1 The Autolube feeds an optimum amount of lubricating oil to the engine under any operating condition, thus featuring:
 - * Less oil consumption.
 - * Less carbon accumulation.
 - * Less exhaust smoke.
 - * Improved lubricating efficiency.
- 2 The Autolube simplifies fuel supply, thus featuring:
 - * Using straight gasoline directly in the gas tank.
 - * Less fuel contamination.
- 3 The Autolube improves the reliability of lubrication, thus eliminating:
 - * Special care concerning oil/fuel mixing ratios.

2-3. Handling the Oil Pump

The oil pump is a precision-machined assembly. Make no attempt to disassemble it. When you remove the oil pump from the engine, protect it from dust, dirt, etc., and after reinstalling it, bleed and adjust the pump correctly. Proper handling will keep the pump free from trouble.

The oil pump is similar in both construction and operation to other Autolube systems. The only difference is the employment of a 4.0 ϕ plunger.

2-3-1 Checking Minimum Pump Stroke

1 Checking

- a Fully close the accelerator grip.
- b Turn the oil pump starter plate in the direction of the arrow marked on the plate. Then measure the gap between the adjustment pulley and the adjustment plate. Keep the gap as wide as possible by observing it with the eye prior to measuring.

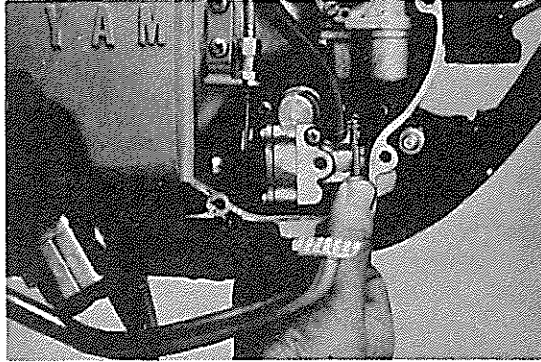

Fig 2-3-1

- c. Insert a feeler gauge (0.15 mm) into the gap.
If the gap allows it to enter
.....Stroke is correct.
If the gap does not allow
.....Stroke is insufficient.

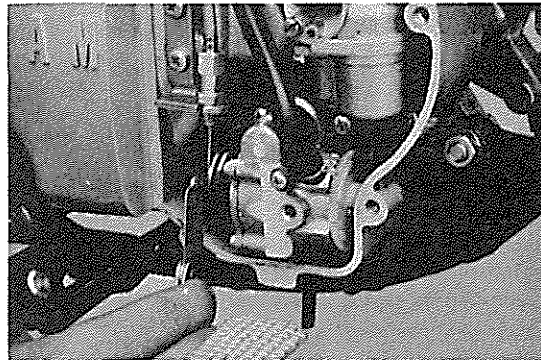

Fig 2-3-2

2 Adjustment

- a Remove the adjustment plate lock nut, and then remove the adjustment plate.

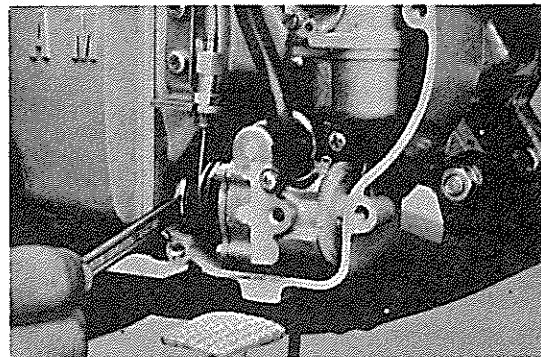

Fig 2-3-3

- b Install a 0.1 mm adjustment shim where the adjustment plate was
 - c Reinstall the adjustment plate lock nut, and measure minimum stroke. When the gap allows a 0.20 mm. feeler gauge to enter but does not allow a 0.25 mm. the stroke is correctly adjusted
- Stroke adjustment tolerance....0.20 to 0.25 mm.

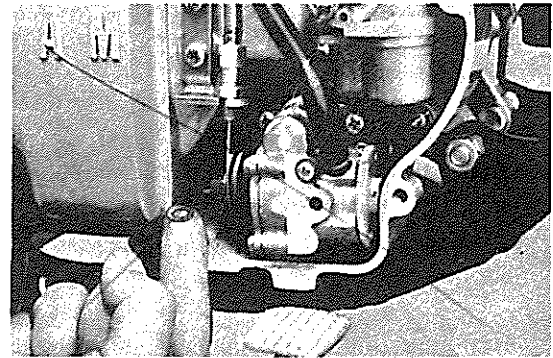

Fig 2-3-4

2-3-2 Carburetor and Autolube Cable Adjustment

Follow the preceding in section 2-3-1 steps to check minimum stroke, and adjust it if incorrect. Then adjust the pump and carburetor as described in the steps below.

1) Throttle Cable Adjustment

- a Adjust the carburetor with the engine at idle, and remove all but 1 mm of slack from cable B
 - To bring the play of the throttle cable into correct adjustment, loosen or tighten the throttle cable adjustment screw
 - To check this adjustment, lightly pull throttle cable B, and engine speed should slightly increase from idling r.p.m. after 1mm of travel.

- b Next, adjust throttle cable(A) so that the gap as shown in Fig 2-3-6 below will be between 0.5 and 1.0 mm. (0.02 ~ 0.04 in.)
 - Check the play of the throttle cable (A) by pulling on the outer part of the throttle cable. If the play is excessive or insufficient, adjust the play using the adjustor.

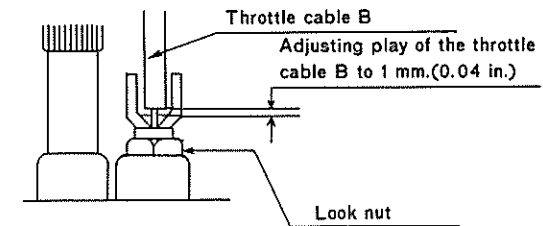

Fig 2-3-5

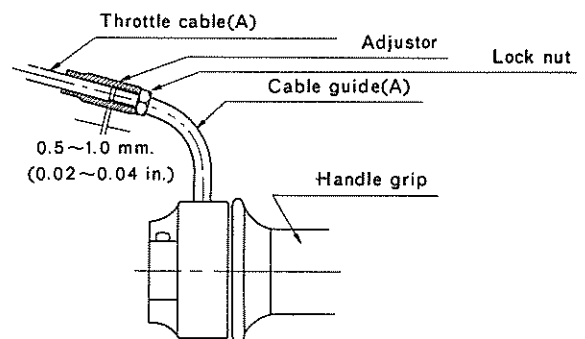
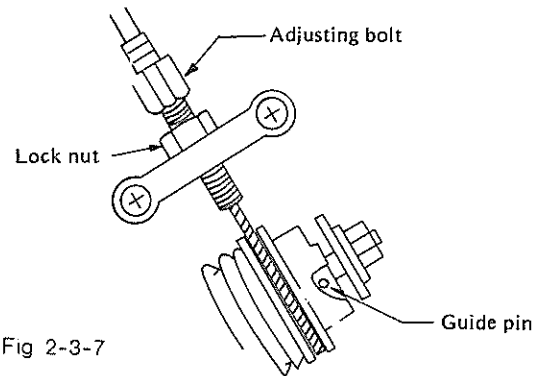

Fig 2-3-6

2) Autolube Cable Adjustment

With the throttle cable properly adjusted, check the pump guide pin location. It should be no closer than 1.5mm (.060") to the raised boss of the pump pulley. If it is too close, loosen the lock nut (see Figure 2-3-7) and turn the adjusting bolt until adjustment is correct. Tighten lock nut.

Next, turn throttle to full open position, the guide pin should not strike the raised boss of the pump pulley in this position, if it does, loosen the adjusting bolt slightly to provide clearance.



2-3-3 Bleeding

When the pump has been removed or the Autolube oil has run out, air will enter the pump. The air will cause an irregular flow of oil after the pump is mounted again or the oil tank is refilled. In order to prevent such an irregular flow of oil, bleed the pump in the following manner:

- 1) Remove the bleeder bolt.

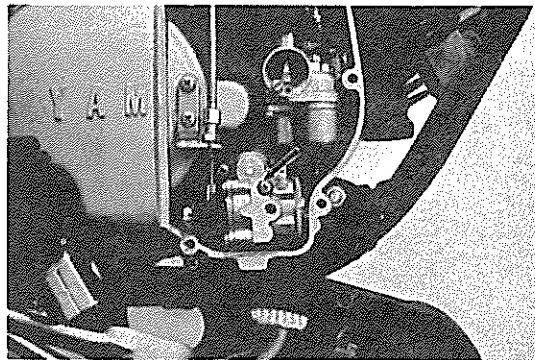

Fig 2-3-8

- 2) Next, rotate the starter plate in the direction of the arrow marked on the plate. Continue turning the plate until no air comes out with the oil and tighten the bleeder bolt. To facilitate this bleeding, fully open the accelerator grip and rotate the starter plate. As the plunger stroke becomes greater, the air can be quickly bled.

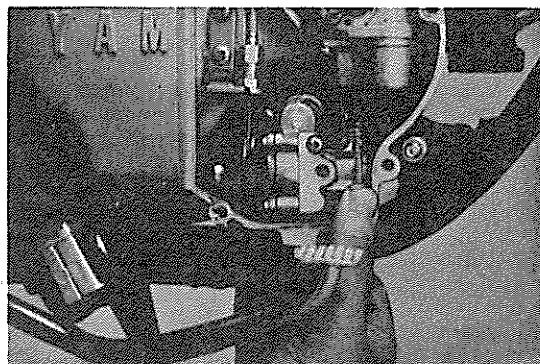

Fig 2-3-9

CHAPTER 3 ENGINE

This chapter describes the disassembly and reassembly of the engine, its removal from the chassis, and the necessary service data. However, except when overhauling the crankshaft assembly, transmission, shifter mechanism or bearings and oil seals in the crankcase, it is suggested that engine be serviced without removing it from the chassis. This will save a lot of time and labor.

Preparation for disassembly of the engine :

- 1) All dirt, mud, dust, and foreign material should be thoroughly removed from the exterior of the engine assembly before removal and disassembly. This will prevent any harmful foreign material from entering the interior of the engine assembly.
- 2) Before engine removal and disassembly, be sure you have proper tools and cleaning equipment so you can perform a clean and efficient job.
- 3) During disassembly of the engine, clean all parts and place them in trays in order of disassembly. This will make assembly time faster and easier, and insure correct installation of all engine parts.

3-1 Engine Removal

- 1 Start the engine and warm it up for a few minutes, then turn off the engine and drain the transmission oil

(Volume of oil 800-850 cc 10.85 US qt)
YAMALUBE 4-CYCLE or SAE 10W-30 "SE"

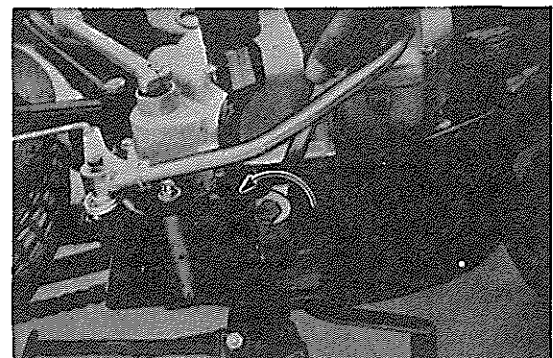

Fig 3-1-1

- 2 Pull out the seat fitting pin and remove the seat by pulling it backward.



Fig 3-1-2

ENGINE - Engine Removal

- 3 Disconnect the fuel line at the bottom of the fuel tank. Remove the tank mounting bolt (13) and lift the fuel tank off.

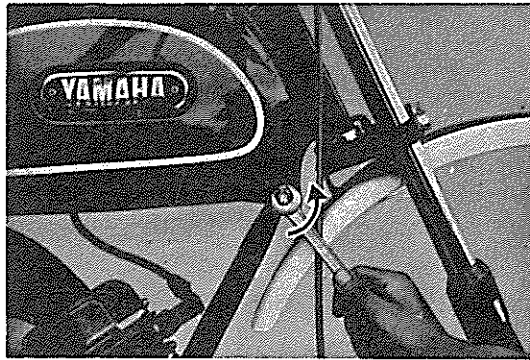

Fig 3-1-3

- 4 Remove the connector from the magneto lead wire and remove the plug cap.

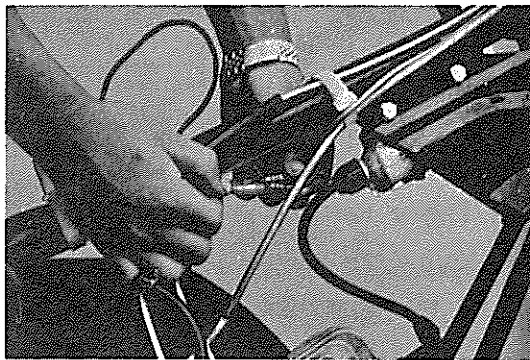

Fig 3-1-4

- 5 Remove the muffler
 - a) Remove the exhaust pipe nut.

Use the special wrench. Hammering on the nut will only damage it and/or the cylinder.

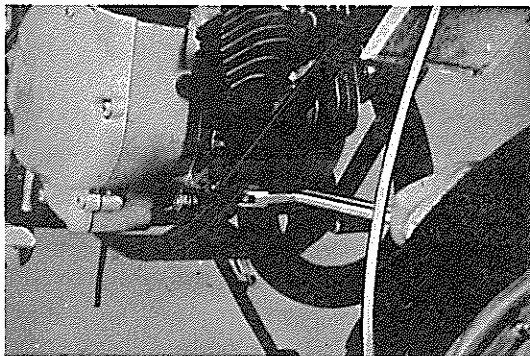

Fig 3-1-5

- b) Remove the muffler holding bolts (13 mm)

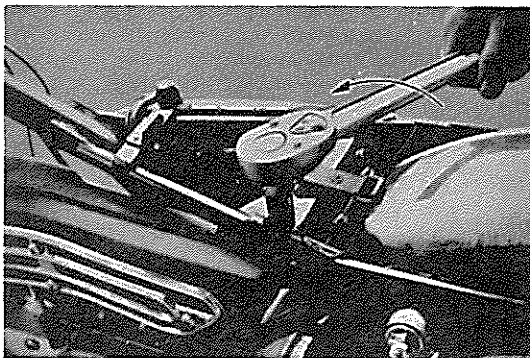

Fig 3-1-6

- 6 Remove the change pedal
(10 mm)

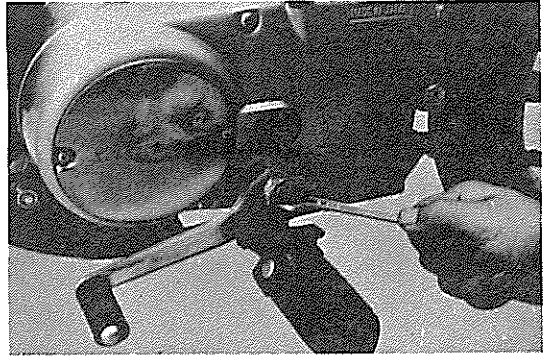

Fig 3-1-7

- 7 Remove the lefthand crankcase cover
(⊕ screwdriver)

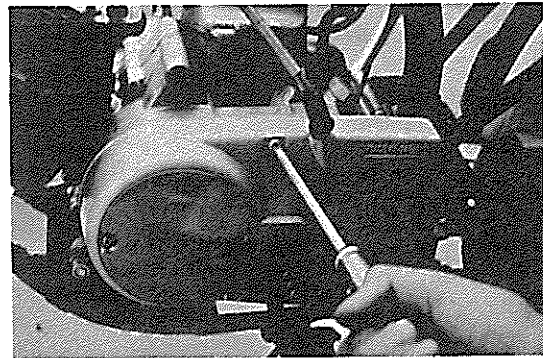

Fig 3-1-8

- 8 Disconnect the master link and remove the chain.

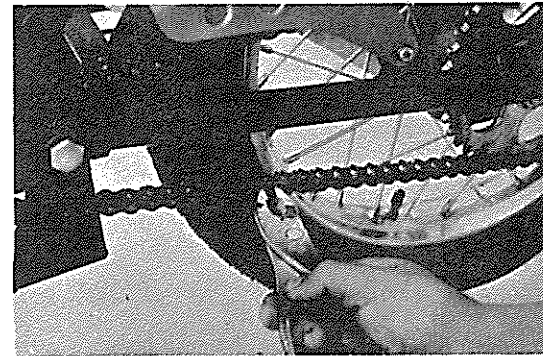
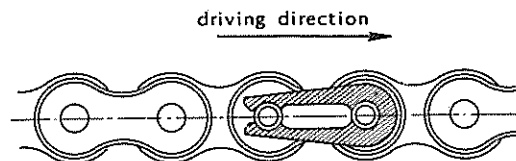

Fig 3-1-9

When reconnecting the chain be sure the master link is facing in the correct direction.



After reconnecting the chain adjust the free play to 25 mm. (1 in.) up and down at the center of the lower section with the rear wheel on the ground.

ENGINE - Engine Removal

- 9 Remove the pump cover and pump cable
(⊕ screwdriver)



Fig 3-1-10

- 10 Remove the oil pipe and plug the hole with a bolt to stop the flow of oil from the tank.

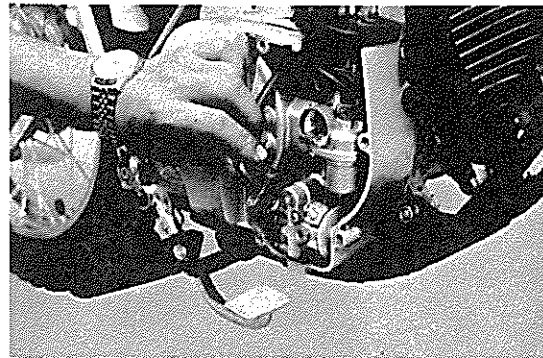

Fig 3-1-11

- Remove the fuel line and remove the carburetor
(⊖ screwdriver)

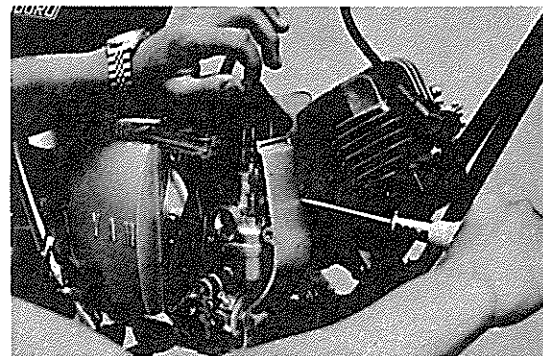

Fig 3-1-12

12. Remove the four engine mounting bolts
(13 mm)

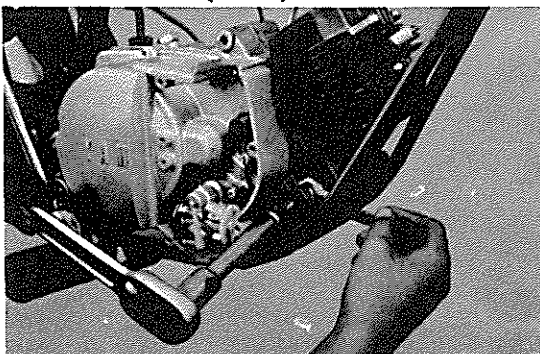

Fig 3-1-13

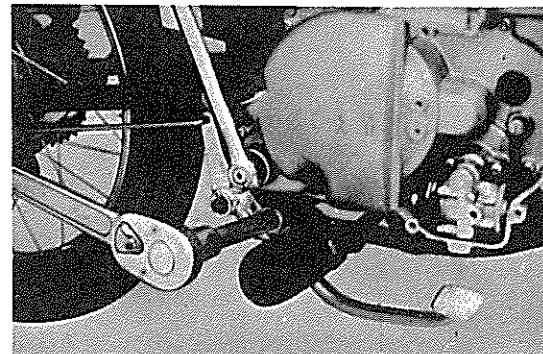

Fig 3-1-14

- 13 Remove the engine from the frame.

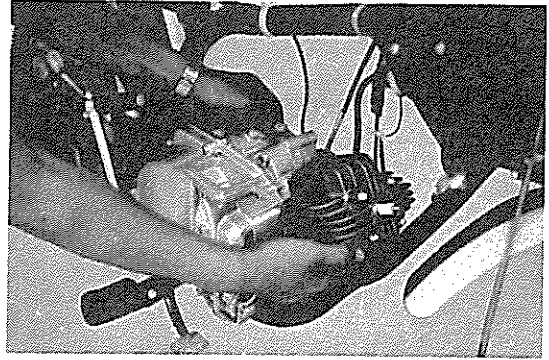

Fig 3-1-15

3-2 Cylinder Head

The cylinder head is bolted on the cylinder with special nuts.

A Removing

Remove the four special nuts from the top of the cylinder head, then the head and head gasket. Reverse the sequence for reinstallation. Replace the gasket, if damaged or in questionable condition.

(10 mm)

Note: During reassembly the head bolts must be torqued to 90 in/lbs in pattern, and in successive stages. Do not torque a hot engine and for most accurate readings, place a small amount of light weight oil on the threads first.

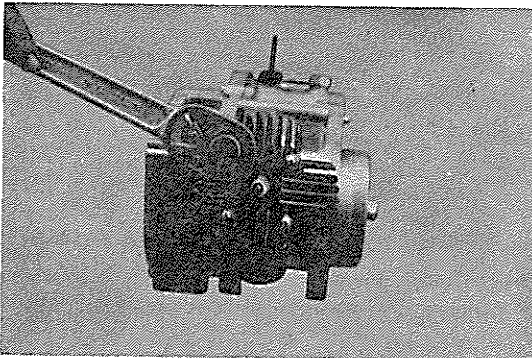

Fig 3-2-1

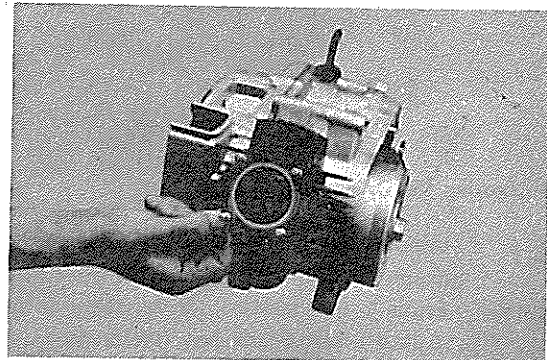

Fig 3-2-2

B Removing Carbon Deposits

Carbon deposits on the cylinder head combustion chamber and top of the piston will result in an increase in the compression ratio, as well as pre-ignition and engine overheating.

Scrape the cylinder head and piston dome clean. Use a rounded scraper to avoid damaging the aluminum.

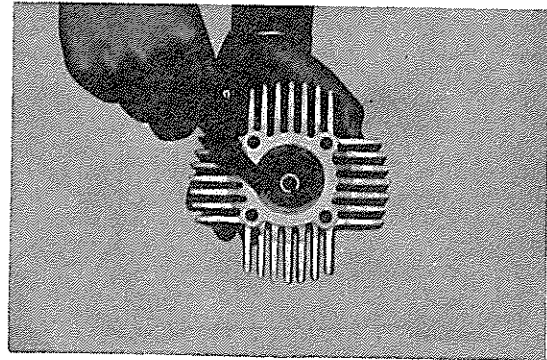

Fig 3-2-3

3-3 Cylinder

- A 1) Remove the cylinder by striking it lightly with a soft faced hammer.

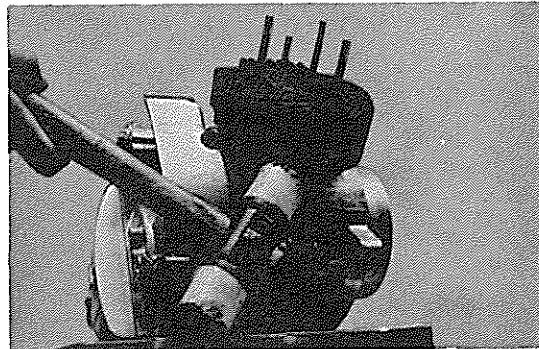

Fig 3-3-1

- 2) Always replace the cylinder base gasket when reassembling.

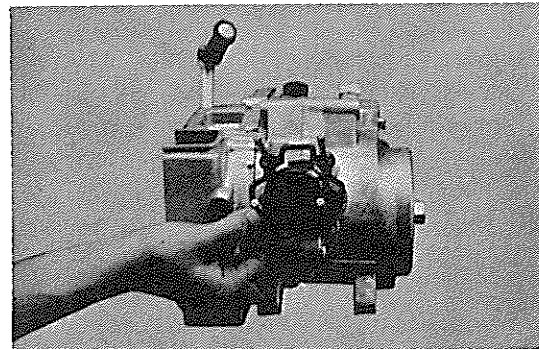
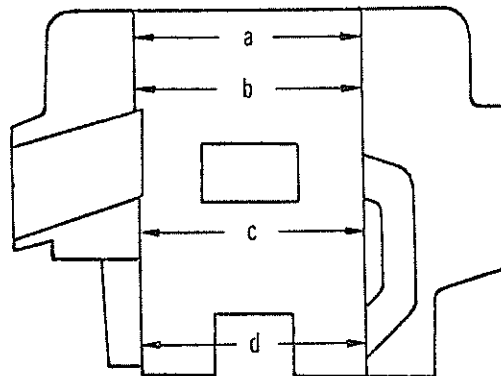
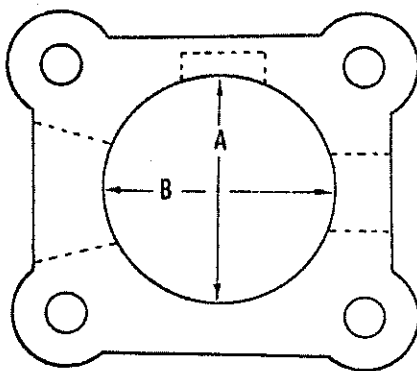

Fig 3-3-2

B Checking the Cylinder for Wear

- 1) Measure the amount of wear of the cylinder wall with a cylinder bore measuring micrometer or cylinder gauge. (Measure it at four depths while positioning the instrument parallel, and then at right angles to the crankshaft.) If the difference between the maximum and minimum diameter exceeds 0.05 mm. (0.0019") rebore and hone the cylinder.



- 2) The piston clearance between the piston and the cylinder is 0.040-0.045 mm (0.0016"-0.0018")

C Cylinder Reconditioning

- 1) Pistons are available in 0.25 and 0.50 mm. (0.010" and 0.020") oversizes.
- 2) The cylinder should be rebored and honed to the diameter of the oversize piston plus the minimum allowable clearance.
- 3) The error between the maximum and minimum diameters after honing should be no more than 0.04 mm. (0.0015")
- 4) If cylinder rebores is necessary, be sure to chamfer all port edges to prevent the rings from catching and breaking on a sharp port edge.

D Removing Carbon Deposits

Scrape off the carbon accumulation in the exhaust port of the cylinder with the dulled end of a hacksaw blade.

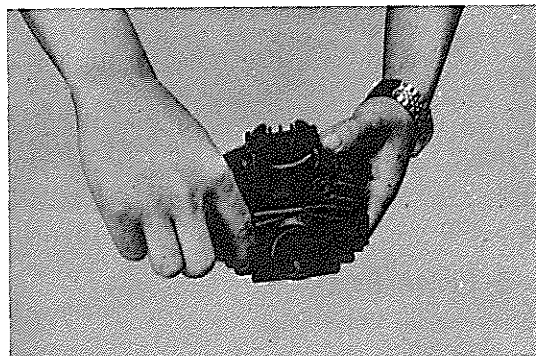

Fig 3-3-3

E Installing the Cylinder

Put your fingers at each end of the piston ring, expand the ring, and slip it onto the piston. Align both ends of the ring with the knock pin in each ring groove. Next, slip the cylinder down over the piston. Compress the rings to prevent ring breakage during installation.

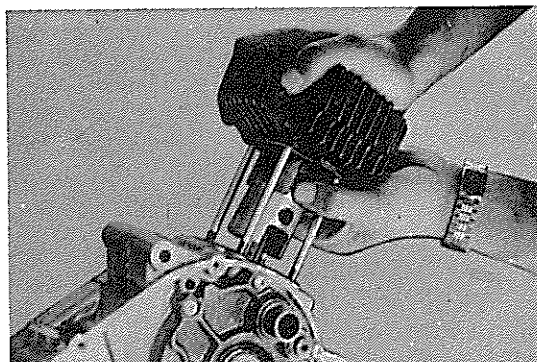

Fig 3-3-4

3-4 Piston Pin

A Pulling out the Piston Pin

Remove the clips at both ends of the piston pin with needle nose pliers, and press out the piston pin with a finger or a slot-head screwdriver.

Note : Before removing the piston pin clips, cover the crankcase with a clean rag, so you will not accidentally drop the clip or other foreign particles into the crankcase.

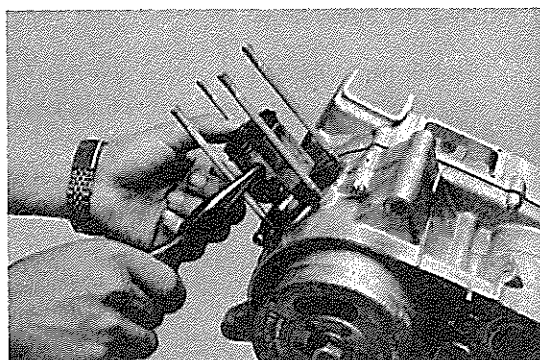

Fig 3-4-1

B Piston-to-Piston pin fit

The piston pin should fit snugly in its bore so that it drags a little as you turn it. If the piston pin is loose replace the pin and/or the piston.

If the pin has step-wear in its center, replace the needle bearing as well as the piston pin. Check the small end of the connecting rod for wear by inserting the piston pin and bearing.



Fig 3-4-2

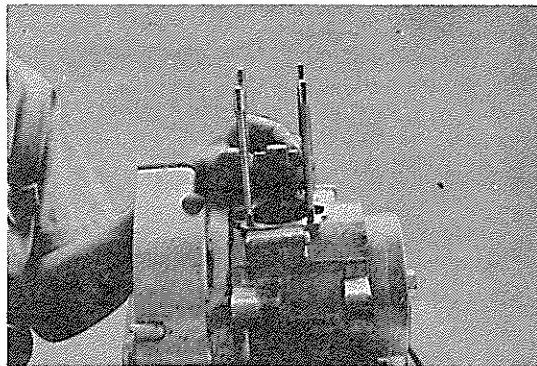

Fig 3-4-3

3-5 Piston Ring

A Removing the Piston Rings

Put your thumbs at each end of the piston ring and pull the piston ring ends apart.

Remove the ring by moving the ring off the piston on the other side of the ring ends and lifting up.

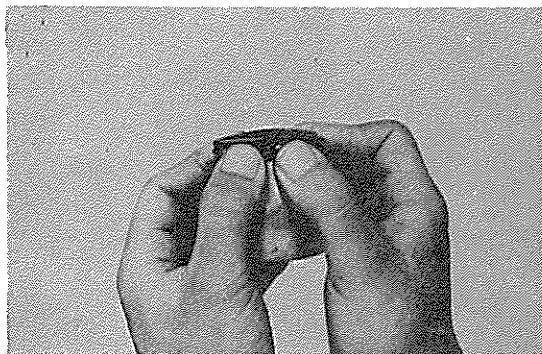

Fig 3-5-1



Fig 3-5-2

B Installing the Piston Rings

First fit No.2 ring over the piston, and then the No.1 ring, and align their end gaps with the locating pin in each ring groove. (Fig. 3-5-3)

The printing on all rings must face up to position the gap properly at the pin.

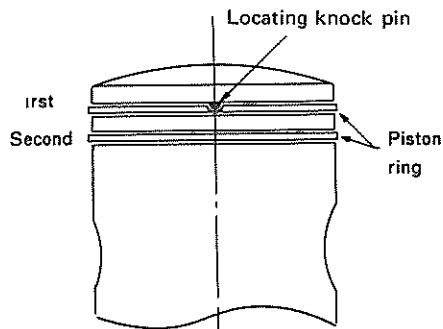

Fig 3-5-3

C. Checking the Piston Rings

- 1) Measuring piston ring wear .Put the ring into the cylinder so that the ring is parallel to the cylinder bottom edge, and then measure the end gap with a feeler gauge (Fig :3-5-4)
The end gap should be between 0.15 and 0.35 mm. (0.006"-0.014") for both No.1 and No.2 rings.

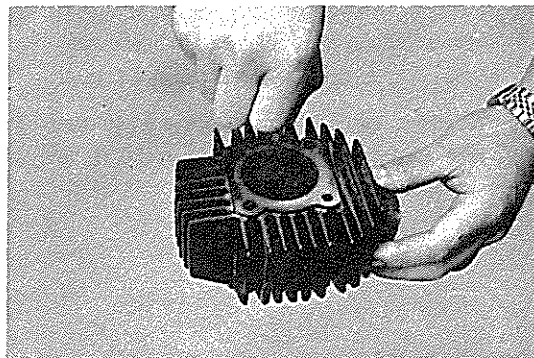

Fig. 3-5-4

- 2) Removing carbon

Carbon on the piston rings and in the ring grooves will make the rings stick in the piston, thus causing gas blow -by.

Remove the rings from the piston, and clean the carbon from the rings and ring grooves, using the end of an old ring as a scraper.

3-6 Piston

The piston is made of a high-silicon aluminum alloy.

A Checking and Correcting the Piston to Cylinder Wall Clearance

- 1) Measuring piston clearance

Piston clearance is the difference between the minimum cylinder bore diameter and the maximum outside diameter of the piston. As described in 4-3 Cylinder, piston clearance should be 0.040-0.045mm (0.0016-0.0018")
To determine the maximum piston diameter, measure the piston with a micrometer at right angles to the skirt 10 mm. (3/8 in.) from its bottom edge. (Fig. 3-6-1)

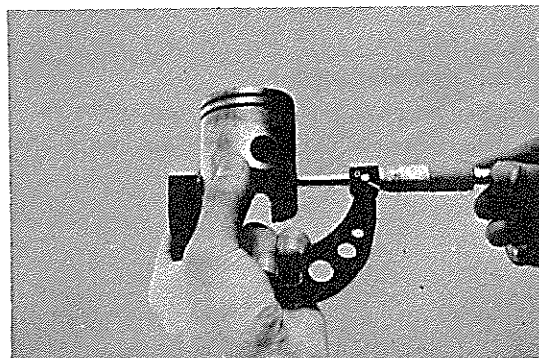

Fig. 3-6-1

- 2) Checking and correcting scratches on the piston

A piston showing signs of seizure will result in noise and loss of engine power. It will also cause damage to the cylinder wall.

If a piston that has seized is used again without correction, another seizure will develop in the same area. Lightly sand the seizure "high spot" on the piston with wet #400 sand paper until smooth.



Fig 3-6-2

ENGINE -Piston Flywheel Magnet

3) Removing Carbon

Remove carbon accumulations on the piston head, using a screwdriver or a saw-blade.

Note Whenever carbon accumulations are removed, take care that the underlying metal is not scored or otherwise damaged.

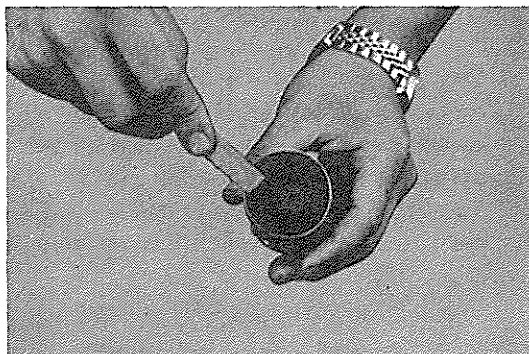

Fig 3-6-3

Carbon and gum accumulations in the piston ring grooves will result in piston ring seizure. Remove them from the ring groove.



Fig 3-6-4

B Piston Installation Direction

Install the piston with the arrow mark on the head pointing forward (toward the exhaust port of the cylinder)

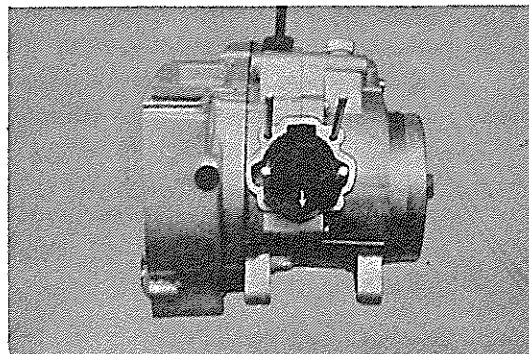

Fig 3-6-5

3-7 Flywheel Magneto

A. Remove the nut using a flywheel magneto holding tool to hold the magneto and a 19 mm socket to loosen it.

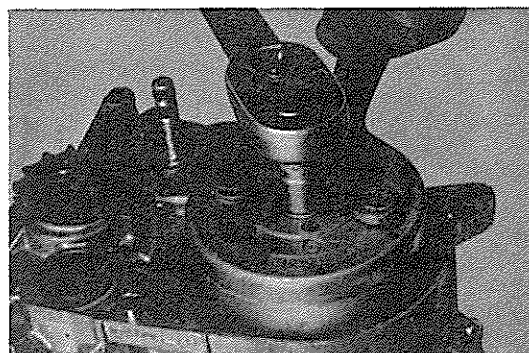

Fig 3-7-1

- B Install the flywheel magneto puller.
Then tighten the bolt. The flywheel magneto will break loose. (left-hand thread)
(Nut: 17 mm)

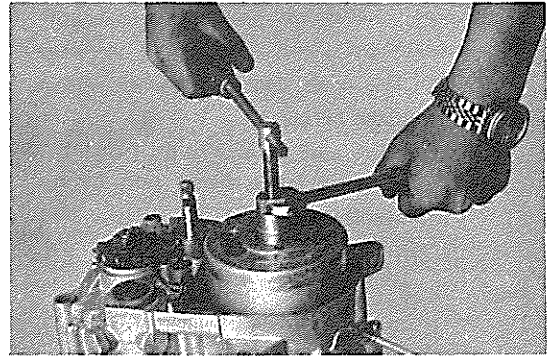

Fig 3-7-2

- C Remove the two screws holding the flywheel magneto base to the crankcase, and remove the flywheel magneto base.

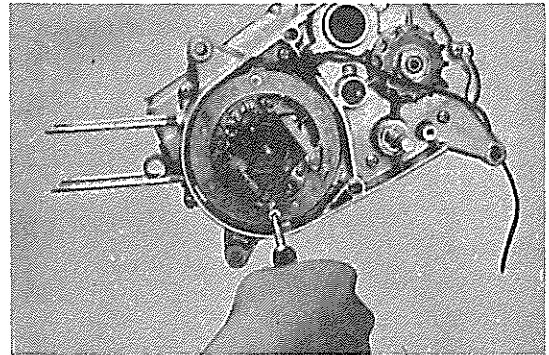

Fig 3-7-3

- D Remove the woodruff key.
It is advisable to place the woodruff key on the flywheel magnets (using its magnetic force) while the key is removed for engine service. This will keep it from becoming lost.
(⊖ Screw driver, hammer)

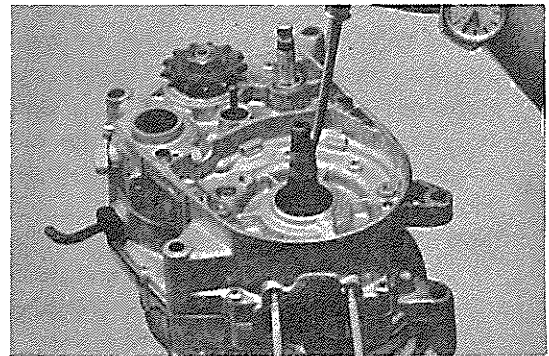

Fig 3-7-4

3-8 Crankcase Cover (R. H.)

A Removal

- 1) Remove the kick crank mounting bolt and the crank.
(10 mm)

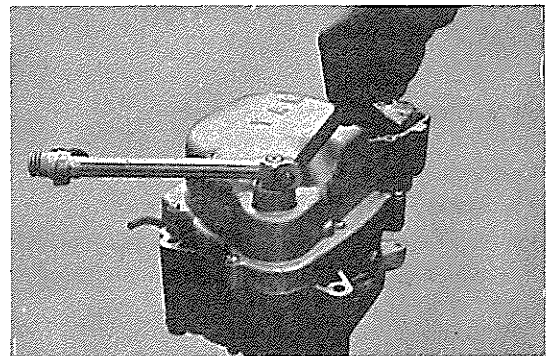

Fig 3-8-1

ENGINE - Crankcase Cover, Clutch

- 2) Remove the seven pan head screws holding the crankcase cover, and then remove the case cover. (The cover can be removed without taking off the oil pump.)

Note : In this case, be sure to pull out the Autolube pump banjo bolt before cover removal.

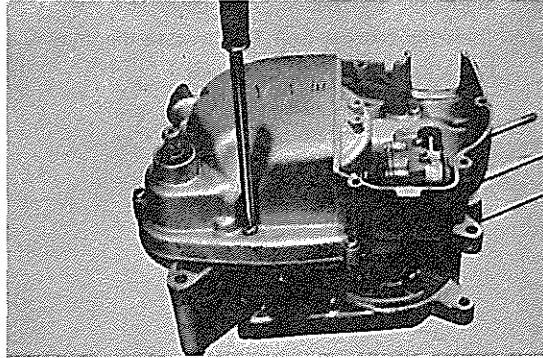

Fig 3-8-2

- 3) Remove the crankcase cover gasket .Replace it, if damaged.

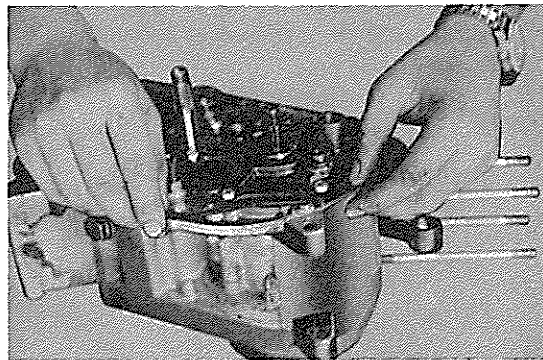

Fig 3-8-3

B Installation

Spread YAMAHA Bond No.5 over the mating surface of the crankcase R. Place the crankcase cover gasket on the crankcase and apply Yamaha Bond No.5 and install the crankcase cover R. Be sure to apply YAMAHA Bond No.5 to the mating surface ; otherwise the crankcase will leak.

Note : When installing the crankcase cover (R) make sure that the pump drive gear (made from synthetic resin) is correctly engaged with the primary drive gear. In addition, make certain that all mating surfaces have been thoroughly cleaned.

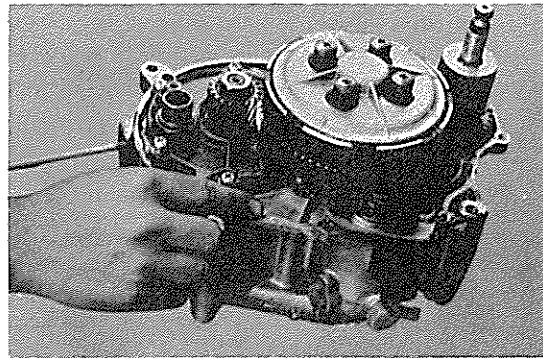
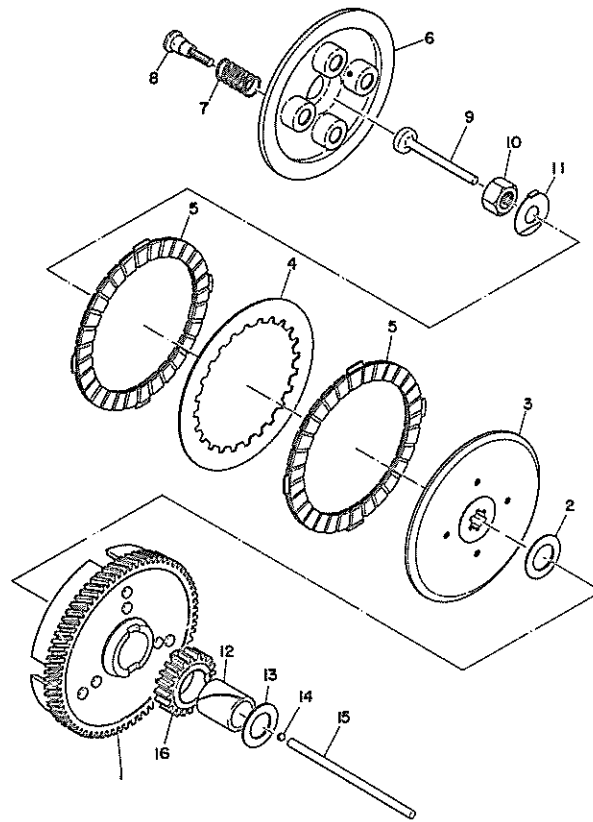

Fig 3-8-4

3-9 Clutch

The clutch is of the wet disc type, consisting of two molded cork friction plates and one steel clutch plate. It is installed on the transmission main shaft.

The clutch housing forms a one piece assembly with the primary driven gear of the primary reduction system. This reduction gear is in mesh with the primary drive gear. The primary reduction ratio is 74/19 (3.894).



1. Primary driven gear ass'y
2. Thrust plate
3. Clutch boss
4. Clutch plate
5. Friction plate
6. Pressure plate
7. Clutch spring
8. Spring screw
9. Push rod 1
10. Lock nut
11. Lock washer
12. Spacer
13. Thrust plate
14. Ball
15. Push rod 2
16. Kick pinion gear

Fig 3-9-1 Clutch ass'y exploded view

A. Removing the Pressure Plate

Remove the four clutch spring holding screws, and take out the pressure plate and push crown.

(⊖ Screwdriver)

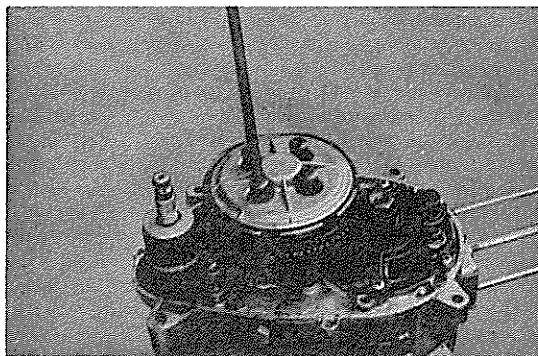

Fig. 3-9-2

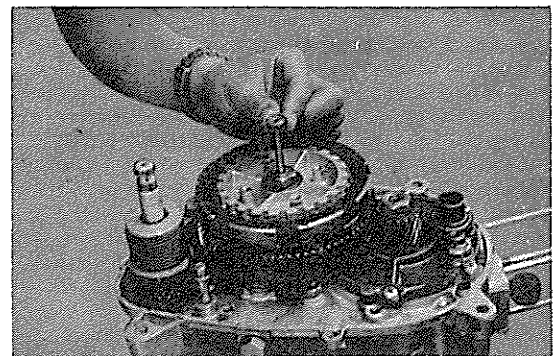

Fig. 3-9-3

ENGINE - Clutch

B. Removing the Clutch Boss

Install the clutch holding tool on the clutch boss.
Loosen the lock nut, and then remove the clutch boss.
(19 mm)

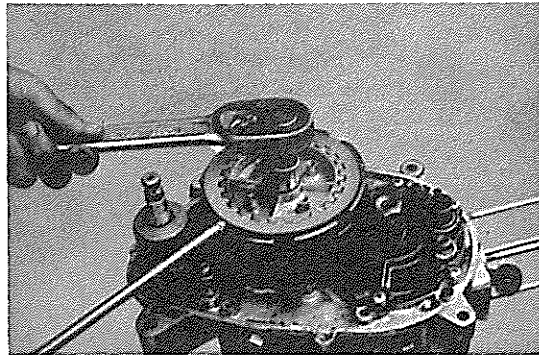

Fig. 3-9-4

C. Checking the Clutch Spring

If the free length of the spring is 1 mm. (0.04 in.) or more shorter than the standard free length, replace it.
(Slide calipers)

Free length 34 mm. (1.340 in.)

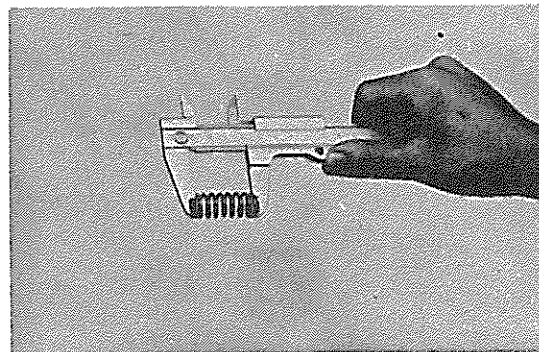

Fig. 3-9-5

D. Checking the Friction Plates

Measure the friction plate at several points for wear.
Replace it if it is worn more than 0.35mm.(0.0137in.) or more. Also replace it if uneven contact is quite evident.
(Slide calipers)

Standard thickness = 3.5 mm. (0.137 in.)

Wear limit = 3.15 mm (0.124 in.)

3.5 mm(Standard Thickness)

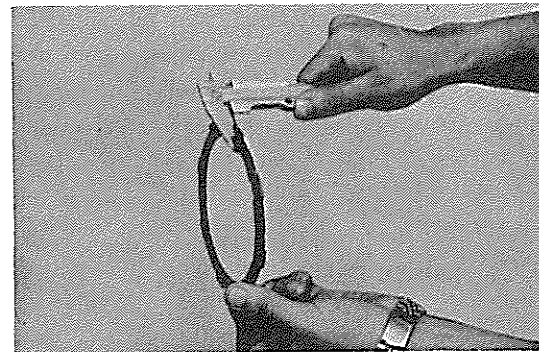
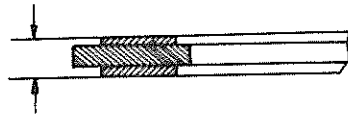

Fig. 3-9-6

E. Clutch Housing Assembly

(integrated with the primary driven gear.)

1) Inspection

Insert the primary gear retaining collar (spacer) in the primary driven gear boss and check it for radial play. If the play is excessive (allowable clearance is between 0.009~0.048 mm.) replace the gear retaining collar because it will cause excessive noise. If any scratches are found, replace the spacer to avoid impaired clutch action.

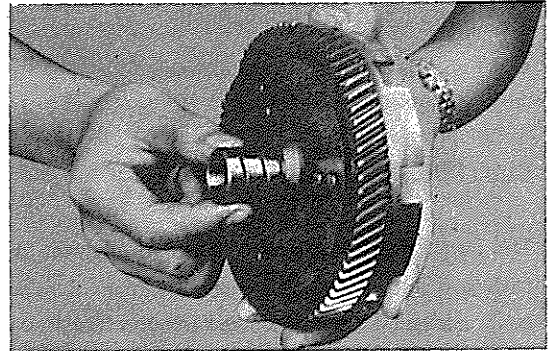

Fig.3-9-7

F. Checking the Primary Gear Retaining Collar (Spacer)

Place the primary gear retaining collar around the main axle and again check it for radial play. If play exists (allowable clearance is between 0.020~0.062 mm.) replace the gear retaining collar. Replace any collar with step-wear on its outer surface.

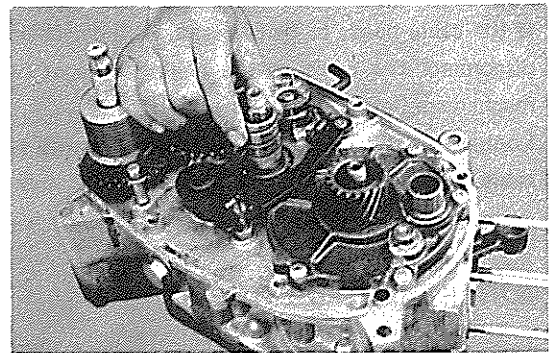

Fig. 3-9-8

G. Checking the Push Rod

Remove the push rod and roll it over a surface plate. If the rod is slightly bent, you could straighten it. Replace it if it is drastically bent or worn.

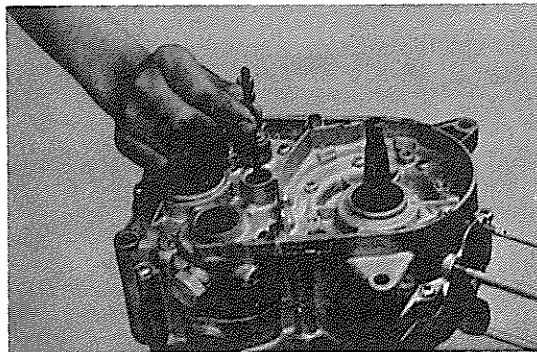

Fig. 3-9-9

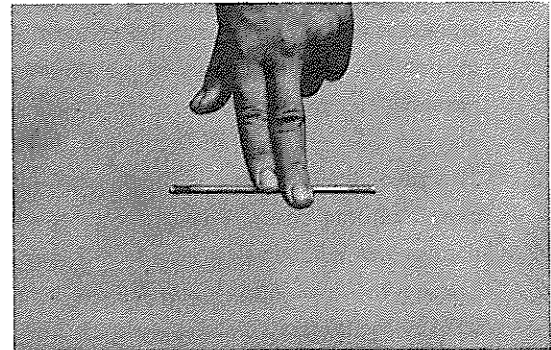

Fig. 3-9-10

2. Inspection and Adjustments

The methods of inspection and adjustment are discussed below. This information will be of value in your daily inspections.

CLUTCH CABLE MAINTENANCE

The clutch cable requires periodic lubrication to prevent the cable strands from rusting or hanging up in the casing. First, disconnect the cable from the clutch lever by screwing the adjuster all the way back to the cable casing. This will provide enough free play in the cable for you to slip the cable out of the lever holder through the slot in the lock nut, adjuster, and holder. Hold the cable upright and allow several drops of liquid graphite to flow down the cable. Hold the cable upright for several minutes to permit complete lubrication.

If the cable needs to be replaced, then perform the steps above and disconnect the cable at the lever. Next, disconnect the cable at the engine. Begin by taking off the cover that houses the clutch activating mechanism (left side of the engine).

Looking at the inside of this cover, you will see the clutch actuating arm. Push the arm up and lift the cable end off. Removing the old cable and hooking up the new one will take but a few moments.

CLUTCH CABLE ADJUSTMENT:

The clutch lever should have .080 to .120 in. (2 to 3mm) free play to maintain full pressure against the clutch facing. If the play is excessive, the clutch will not disengage. If the free play is insufficient, the clutch will slip.

1. First, loosen the lock nut above the left crankcase cover. Then turn the adjuster either in nor out depending on which direction is necessary to arrive at 2-3mm (1/16"-1/8" free play).
2. The second adjustment is located behind the clutch adjuster cover. Removing the cover will expose the adjusting set screw and lock nut. Loosen the lock nut, rotate the set screw in until it lightly seats against a clutch push rod that works with the set screw to operate the clutch. Back the set screw out ¼ turn and tighten the lock nut. This adjustment must be checked because heat and clutch wear will affect this free play, possible enough to cause incomplete clutch operation.

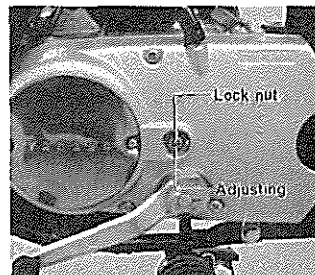
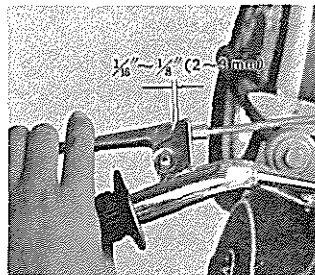

3-10 Primary Drive Gear

A. Removal

Feed a rolled-up rag between the teeth of the primary drive gear and the primary driven gear to lock them, and loosen the primary drive gear lock nut. The primary gear can then be forced off.

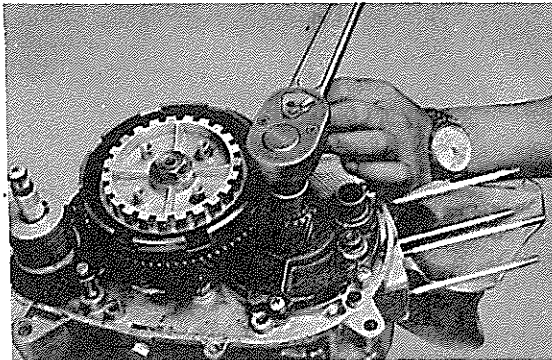

Fig. 3-10-1

3-11 Kick Starter Mechanism

The primary kick-starter system (one-touch kick-starter) is employed. However, a new "non-constant-mesh" mechanism has been introduced into the kick-starter, instead of the constant-mesh kick gear type, such as the ratchet and roller-lock systems.

That is, the kick gear meshes with the idler gear only when the kick starter pedal is kicked. After the engine has started, the kick gear and the idler gear disengage. This mechanism not only eliminates noise resulting from the constant mesh of the kick gear with the idler gear, but also greatly contributes to the durability of the kick starter assembly.

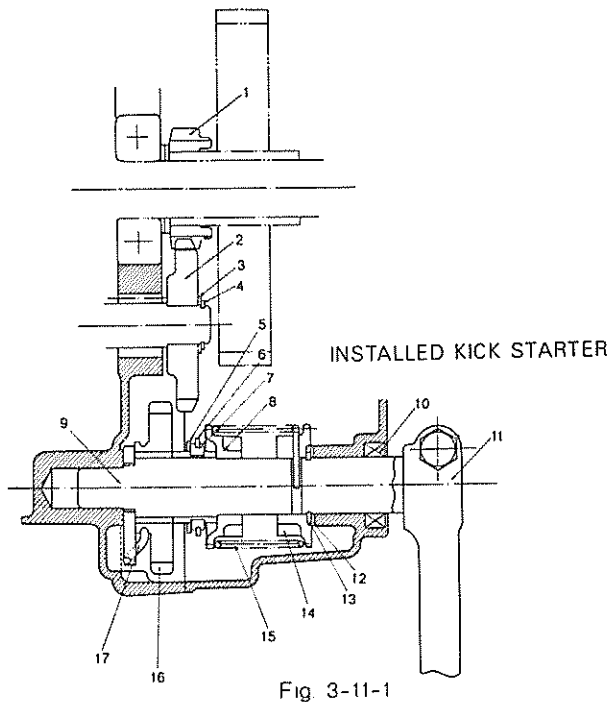
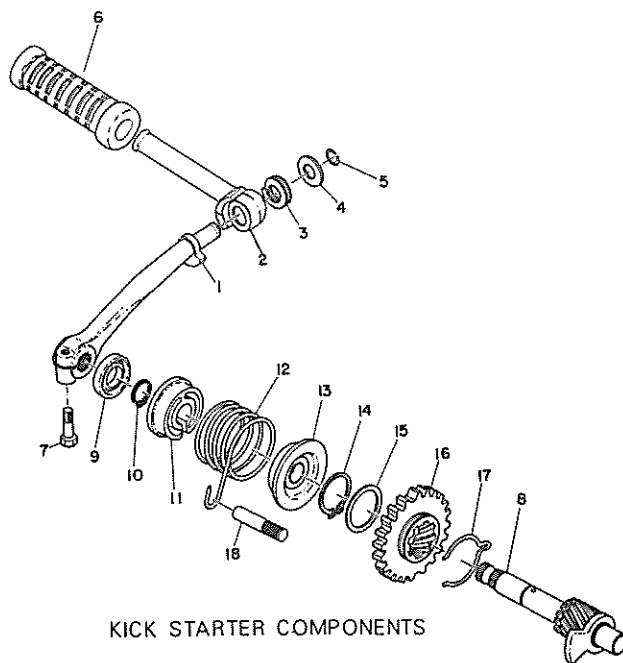

Fig. 3-11-1

1. Kick pinion gear
2. Kick idle gear
3. Thrust washer
4. Circlip
5. Shim
6. Circlip
7. Kick gear holder
8. Spring guide
9. Kick axle
10. Oil seal(S-20-30-7)
11. Kick crank ass'y
12. Shim
13. Circlip
14. Spring cover
15. Kick spring
16. Kick gear
17. Kick clip



KICK STARTER COMPONENTS

Fig. 3-11-2

1. Kick crank
2. Kick lever
3. Spring
4. Washer
5. Clip
6. Kick lever cover
7. Bolt
8. Kick axle
9. Oil seal
10. Circlip
11. Spring cover
12. Kick spring
13. Spring guide
14. Circlip
15. Shim
16. Kick gear
17. Kick clip
18. Stopper

A. Removing the Kick Idler Gear

Remove the circlip with clip pliers. Then the kick idler gear can be easily removed.

Note: The location of the shim directly beneath the circlip.

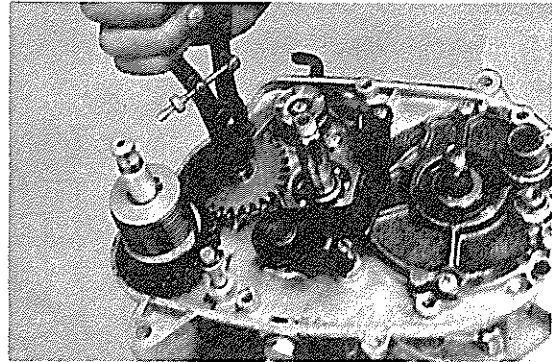

Fig. 3-11-3

b. Removal

1) Remove the kick spring.

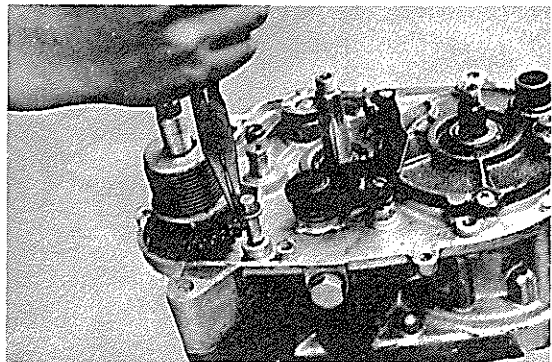

Fig. 3-11-4

2) Then remove the kick starter assembly.

Disassembly of this assembly is unnecessary unless kickstarter repair is required.

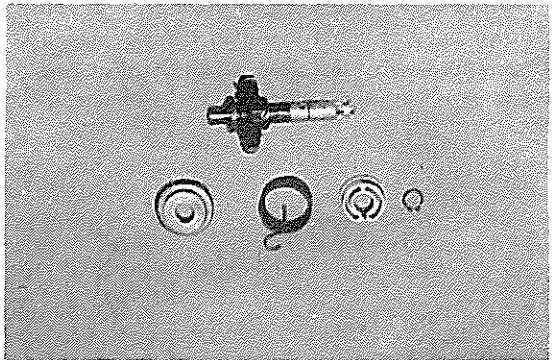

Fig. 3-11-5

3-12 Shift Mechanism

The shift mechanism is designed to select four speeds plus a position neutral position. When the change pedal is moved the gear shift arm A is moved back or forward by the gear shift arm B (see Fig. 3-12-1).

The gear shift drum pin attached to the gear shift drum is pushed by the gear shift arm A, and the gear shift drum begins to rotate.

A total of five gear shift drum pins are attached to the gear shift drum. When the change pedal is moved, the unit is designed to shift through five stages. Neutral, Low, Second, Third and Top, throughout one complete turn of the gear shift drum.

The stopper plate holds the gear shift drum pin so that gear shifting can be correctly positioned at each gear position. The gear shift drum is provided with grooves on its outer surface, and the shift forks move back and forth along their respective grooves to change gears.

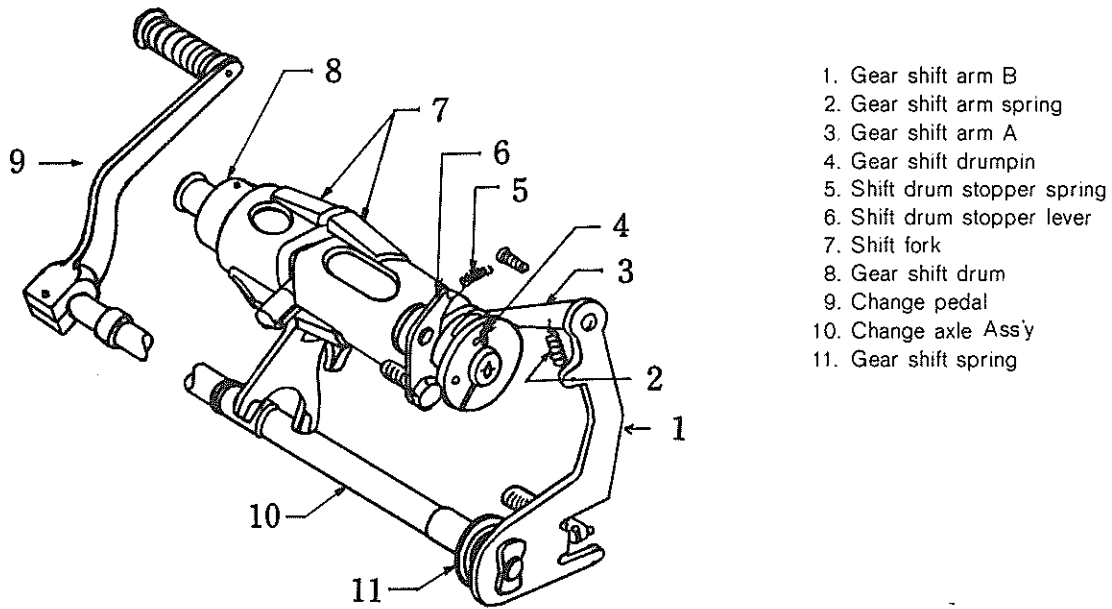

Fig. 3-12-1

A. Gear Shift Pattern

Neutral is at top of the shift pattern. Press down once to select low then remove pressure from the lever. Press down again to select 2nd, and so on for the remainder.

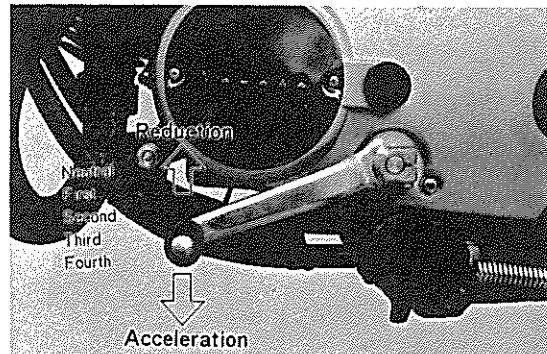

Fig. 3-12-2

A. Removing the Change Axle Assembly

- 1) Remove the circlip and washer from the change axle (left side crank case).
 (⊖ Screw driver)

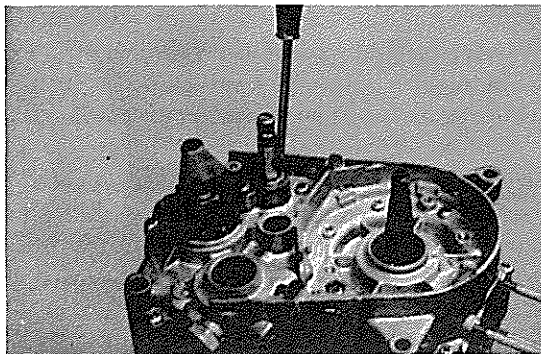

Fig. 3-12-3

- 2) Turn the engine over right side up, and pull out the change shaft assembly.

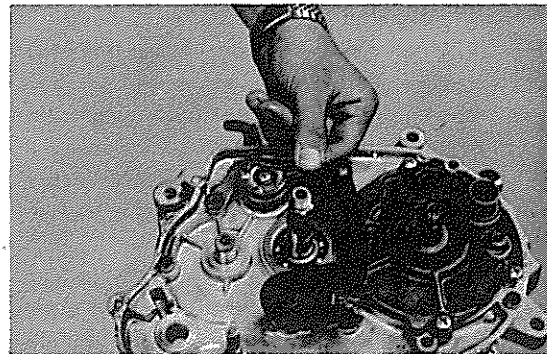

Fig. 3-12-4

B. Checking the gear shift parts (Fig. 3-12-5)

Checking the Gear Shift Return Spring. A broken or fatigued gear shift return spring will impair the return action of the shifting mechanism. Also, check for a bent or damaged shaft.

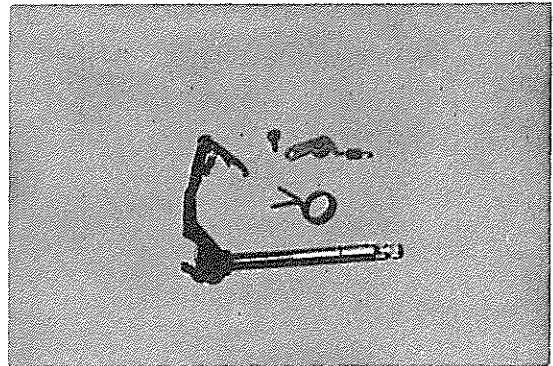

Fig. 3-12-5

C. Adjusting the gear shift arm

Adjusting or correcting the travel of the gear shift arm to prevent improper shifting progression (excess feed or insufficient feed of the gear shift arm) is accomplished by turning the gear shift return spring stop screw (eccentric bolt) in or out.

In second or third gear the measurement A & A' must be equal

(⊖ Screwdriver)

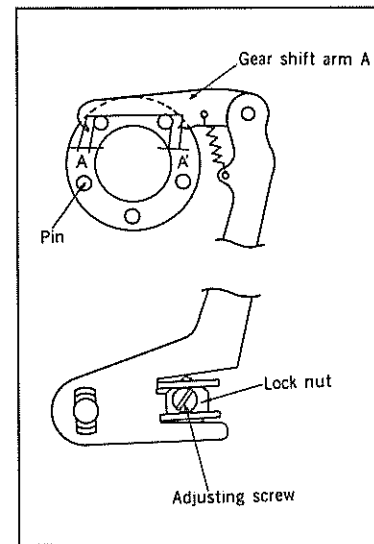

Fig. 3-12-6

3-13 Rotary Valve

A. Removal

- 1) Remove the six valve cover set bolts and remove the valve cover.

(⊕ Screwdriver)

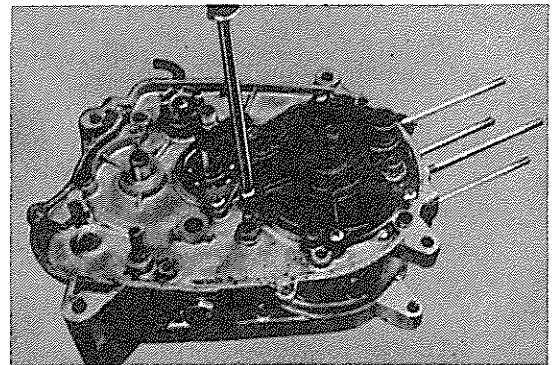

Fig. 3-13-1

2) Remove the valve and valve collar.

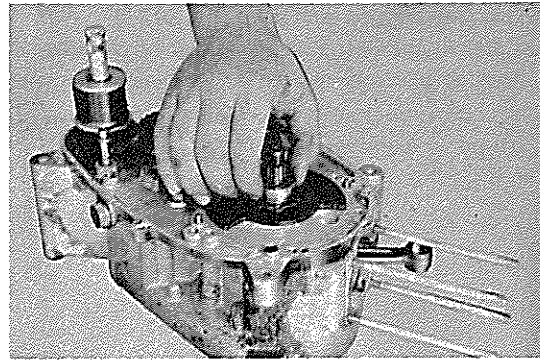

Fig. 3-13-2

3) Remove the valve knock pin. Take care not to damage the surfaces of the crankcase.

See Appendices for proper valve timing during installation.

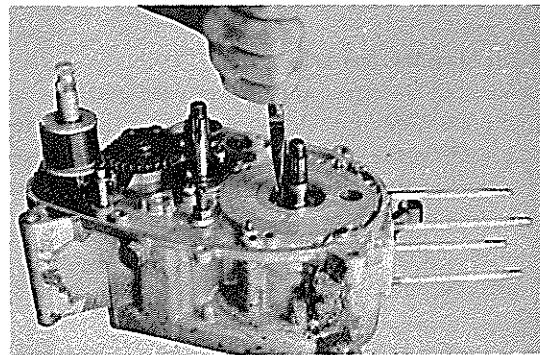

Fig. 3-13-3

B. Checking the Rotary-valve.

1) Install the valve collar in the valve and check for looseness. If it is found too loose, replace it. If the collar is found to have step wear due to locating pin friction, it should be replaced.

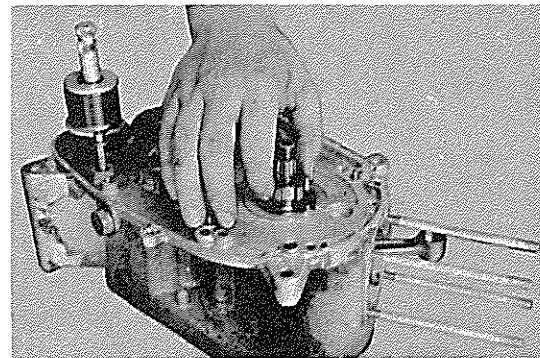

Fig. 3-13-4

2) The O-ring is subject to stretch, flattening or hardening after a long period of use. Any stretched or aged O-ring may fail to snugly fit in the groove. If it is found defective, it should be replaced with a new one. When installing it, grease it.

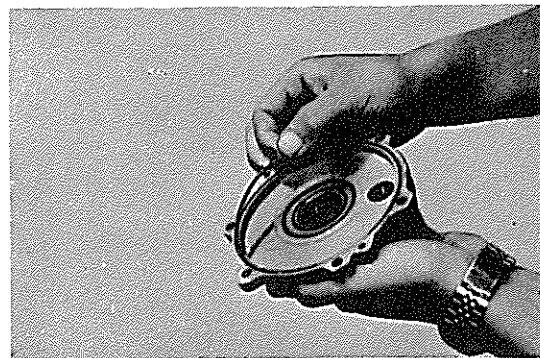

Fig. 3-13-5

- 3) When the valve collar is installed, care should be taken not to nick the crankshaft O-ring. If it is found nicked, replace it. It is advisable to grease the surface of the inner collar and the outer surface of the O-ring.

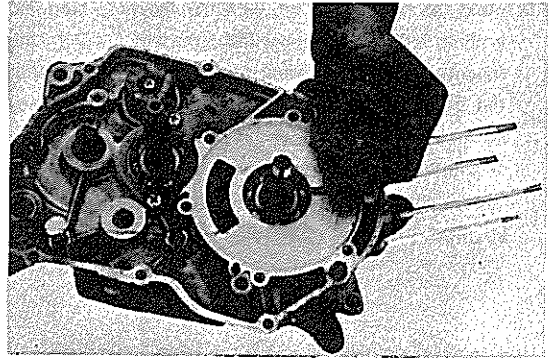

Fig. 3-13-6

- 4) When installing the valve cover, apply good quality grease to the lip so it will slip easily over the shaft.

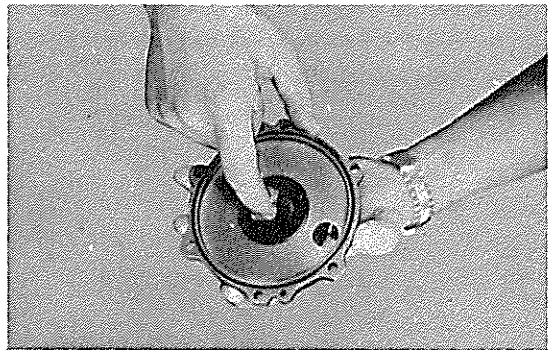

Fig. 3-13-7

3-14 Drive Sprocket

A. Removal

- 1) Straighten the bent edge of the lock washer with a blunt-ended metal punch.
(Flat chisel)

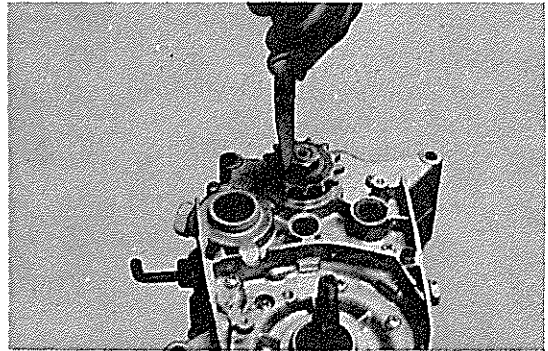

Fig. 3-14-1

ENGINE - Drive Sprocket

2) Hold the drive sprocket with the flywheel magneto holding tool, and remove the sprocket nut. If the flywheel magneto holding tool is not available, shift the transmission to low gear, and fit a monkey wrench on the sprocket nut. Then tap the handle of the wrench with a hammer and the shock will loosen the nut. The best method of removal is an air impact wrench, (21 mm)

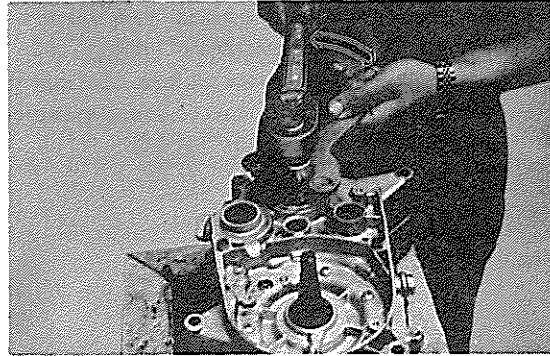

Fig. 3-14-2

3) Remove the distance collar with pliers. (When re-installing the distance collar, apply grease to the oil seal lip groove.)

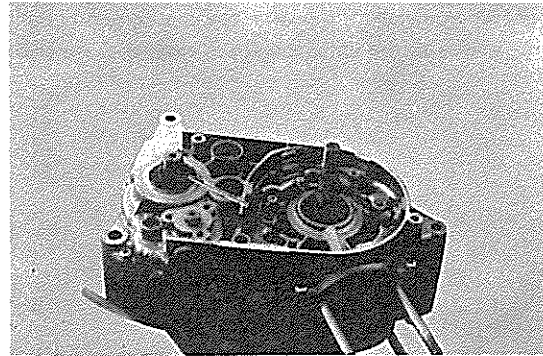

Fig. 3-14-3

B. Inspection

A worn drive sprocket will result in excessive chain noise and shorten the life of the chain. Check the sprocket for worn teeth, and replace if they are worn to the extent shown.

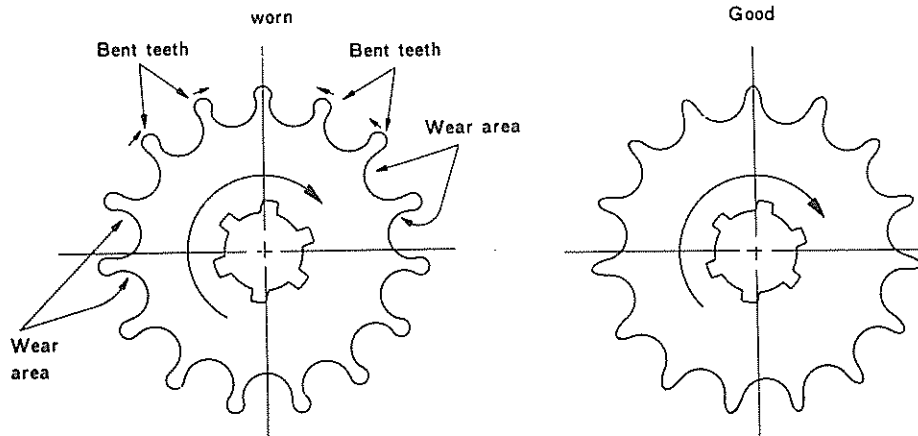

Fig. 3-14-4

3-15 Crankcase

A. Separating

- 1) Remove the neutral stopper.
(21 mm)

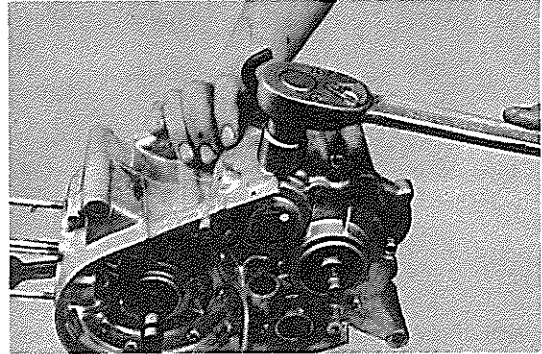

Fig. 3-15-1

- 2) Remove the shift drum stopper lever and stopper spring.
(10 mm)

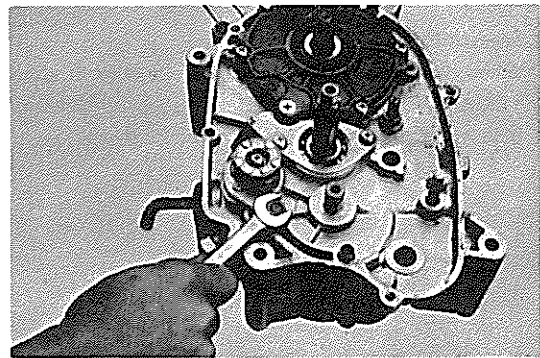

Fig. 3-15-2

- 3) Remove the twelve pan head screws from the left crankcase.
(⊕ Screw driver)

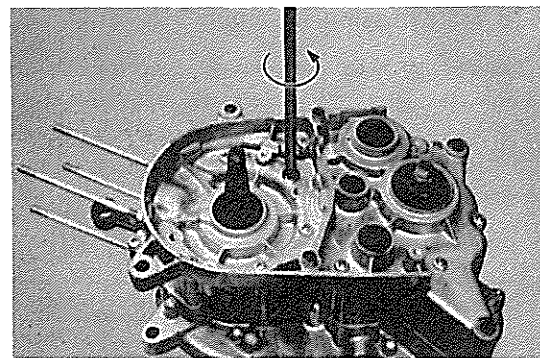

Fig. 3-15-3

- 4) Install the crankcase separating tool on the right crankcase. Divide the crankcase while alternately tapping the main axle and the crankcase with a soft-faced-hammer.

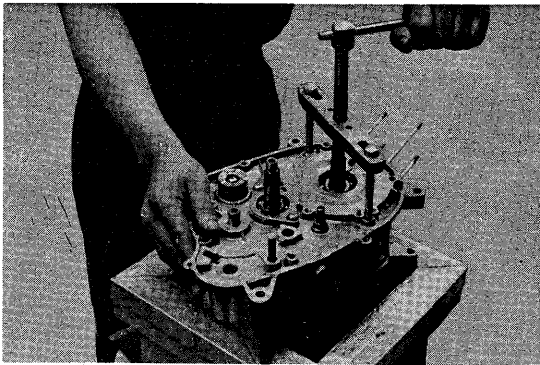

Fig. 3-15-5

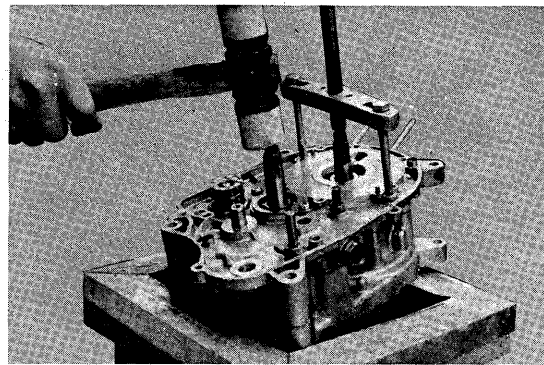

Fig. 3-15-6

Note: Fully tighten the bolts of the crankcase dividing tool, keeping the tool in a horizontal position.

The crankcase is designed to split into two halves, right and left. Only one drain plug is provided for both the transmission and clutch housings. Both housings can be drained at the same time by removing the drain plug.

B. Reassembling

- a) When reassembling the crankcase, be sure to apply YAMAHA BOND No. 5 to the mating surfaces of both halves after cleaning them thoroughly.

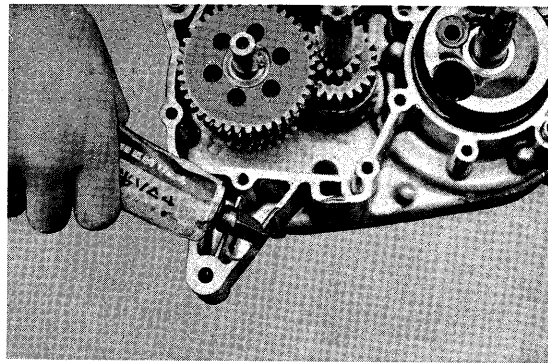

Fig. 3-15-7

3-16 Transmission Assembly

The constant mesh, wide ratio, 4-speed transmission makes it possible to fully utilize the steady performance of the engine throughout the entire speed range from low to high speed.

For layout of the transmission and related parts, refer to Fig. 3-16-1 and 2. The primary reduction ratio is $74/19 = 3.894$. Therefore the total reduction ratios will be; Primary reduction ratio \times Transmission gear reduction \times Secondary reduction ratio = Total reduction ratio.

	Primary Reduction Ratio..... $74/19 = 3.894$	
	Secondary Reduction Ratio..... $41/13 = 3.153$	
	Transmission Gear Reduction Ratio	Total Reduction Ratio
1st	$40/13 = 3.077$	37.773
2nd	$34/18 = 1.889$	23.193
3rd	$30/23 = 1.304$	16.010
4th	$27/26 = 1.038$	12.188

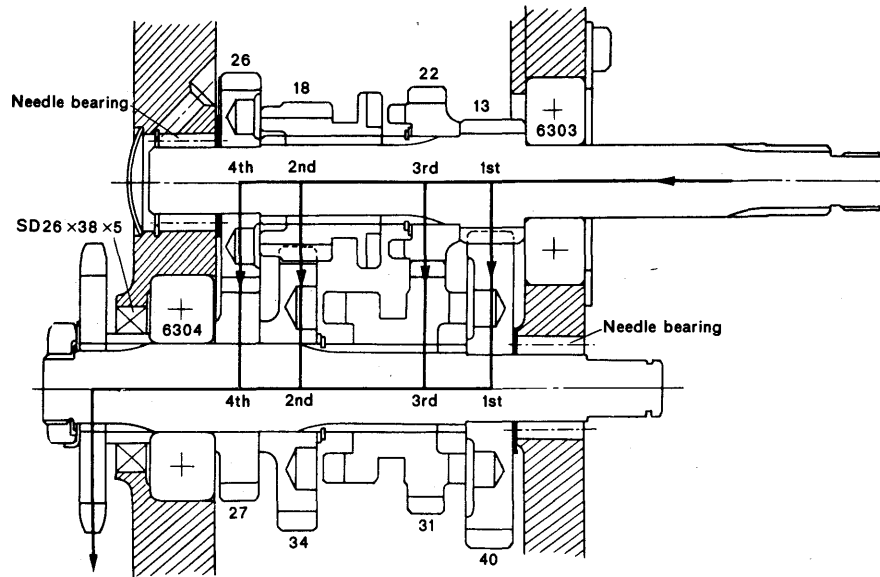
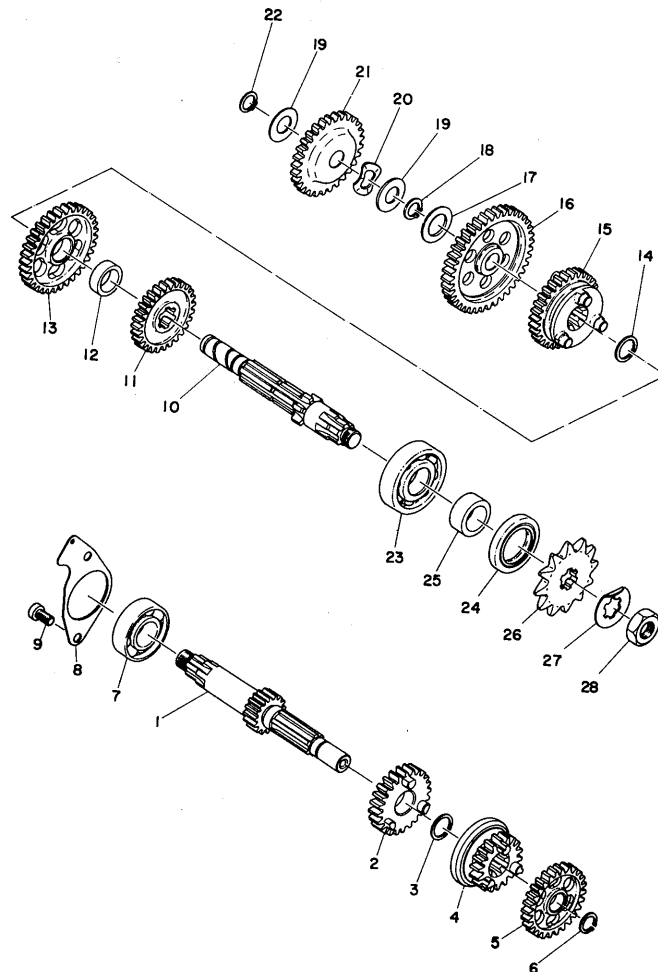

Fig. 3-16-1



1. Main axle
2. 3rd pinion gear
3. Circlip
4. 2nd pinion gear
5. 1st pinion gear
6. Circlip
7. Bearing
8. Bearing cover plate
9. Bolt
10. Drive axle
11. 4th wheel gear
12. Distance collar
13. 2nd wheel gear
14. Circlip
15. 3rd wheel gear
16. 1st wheel gear
17. Shim
18. Circlip
19. Thrust washer
20. Wave washer
21. Kick idle gear
22. Circlip
23. Bearing
24. Oil seal
25. Distance collar
26. Drive sprocket
27. Lock washer
28. Nut

Fig. 3-16-2

ENGINE - Transmission Assembly,

A. Removal

- 1) Pull out the two shift fork guide bars.

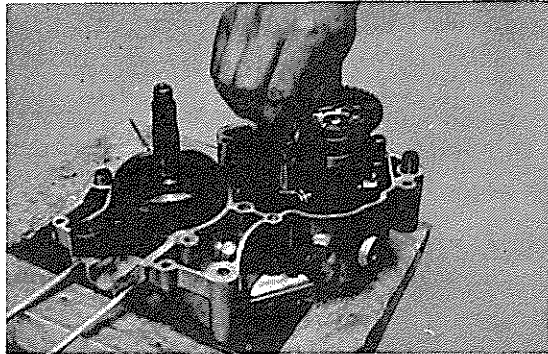

Fig. 3-16-3

- 2) Remove both the transmission assembly and the shift assembly from the crankcase, while tapping the drive shaft end with a soft-faced-hammer.

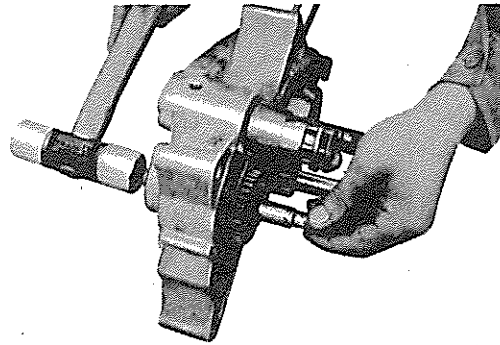

Fig. 3-16-4

B. Reinstallation

Reinstall the transmission and shifter as a unit in the left crankcase half after they are sub-assembled. They cannot be installed separately. The transmission unit must be in neutral during installation.

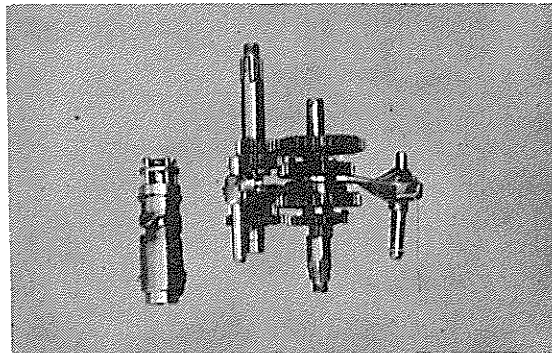
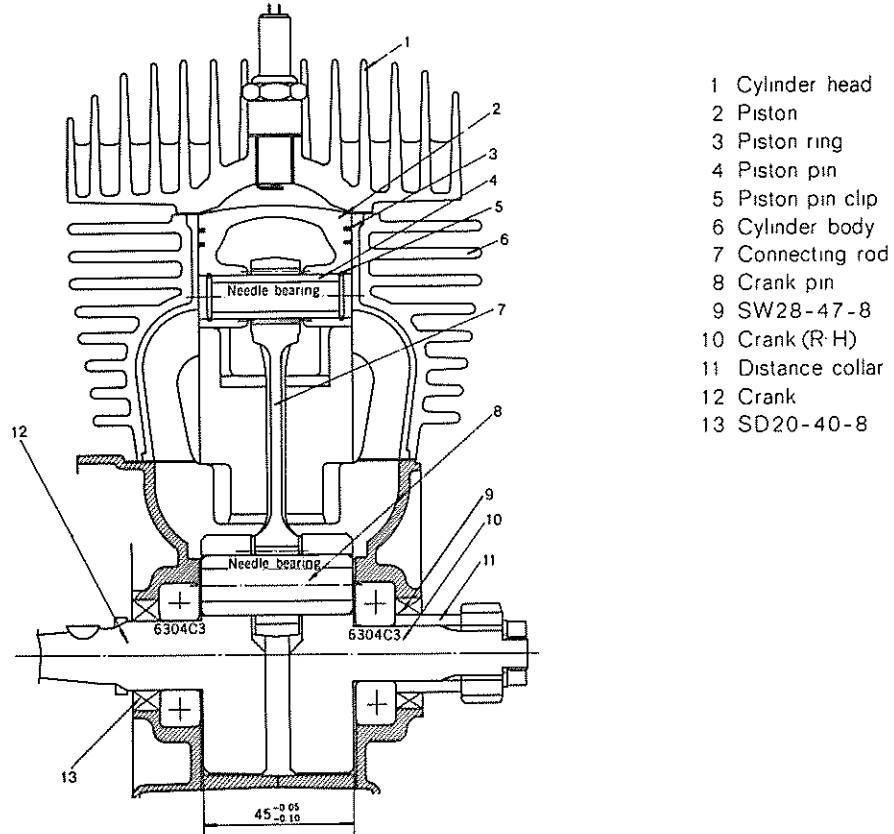

Fig. 3-16-5

3-17 Crankshaft

The crankshaft is a precision piece of work and is subjected to extreme stresses. It should be handled and inspected with special care



- 1 Cylinder head
- 2 Piston
- 3 Piston ring
- 4 Piston pin
- 5 Piston pin clip
- 6 Cylinder body
- 7 Connecting rod
- 8 Crank pin
- 9 SW28-47-8
- 10 Crank (R-H)
- 11 Distance collar
- 12 Crank
- 13 SD20-40-8

Fig 3-17-1

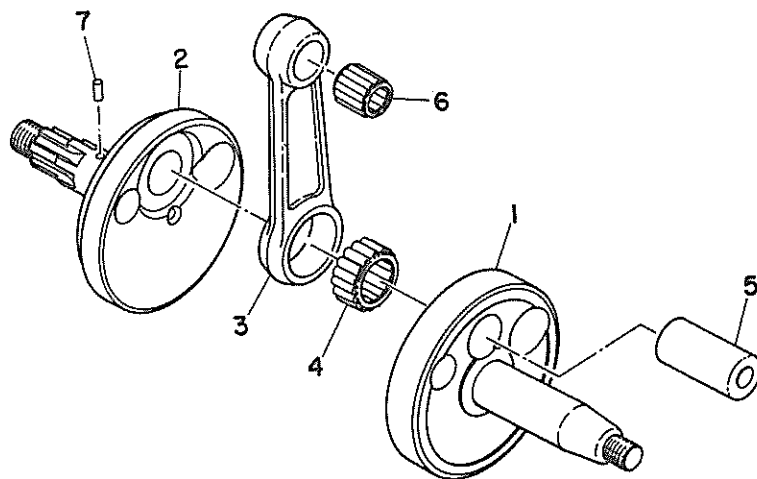

- 1. Crank left
- 2. Crank right
- 3. Rod connecting
- 4. Bearing con-rod big end
- 5. Pin crank
- 6. Bearing con-rod small end
- 7. Pin dowel

Fig. 3-17-2 Crankshaft component parts

ENGINE - Crankshaft

A. Removing the Crankshaft Assembly

Remove the crankshaft assembly with the crankcase separating tool.

Note: Fully tighten the bolts of the crankcase dividing tool, and keep the tool parallel with the crankcase surface.

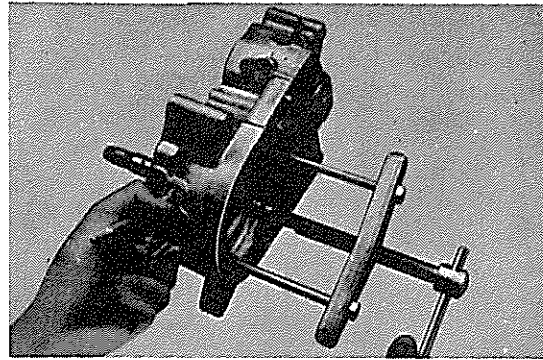

Fig. 3-17-3

B. Installing the Crankshaft Assembly

Install the crankshaft by using the crankshaft fitting tool. Take care not to allow the connecting rod to contact the crankcase. For this, hold the piston at top-dead-center and turn the handle, then tighten the bolt of the special tool.

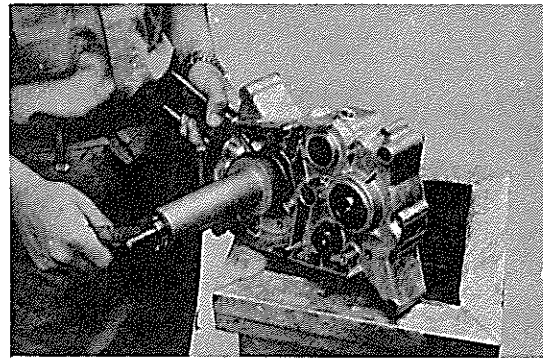

Fig. 3-17-4

C. Inspection and Servicing

1) Checking the crankshaft components

Check connecting rod axial play at the small end (to determine the amount of wear of crank pin and bearing at large end) (Fig. 3-17-5)	Small end play should not exceed 2 mm. (0.078 in.)	If small end play exceeds 2 mm, disassemble the crankshaft, check connecting rod crank pin and large end bearing. Replace defective parts. Small end play after reassembly should be within 0.8~1.0 mm. (0.031~0.04 in.)
Check accuracy of the crankshaft assy runout. (Misalignment of parts of the crankshaft) (Fig. 3-17-6)	Dial gauge readings should be within 0.03 mm. (0.0012 in.)	Correct any misalignment by tapping the flywheel with a brass hammer and by using a wedge.

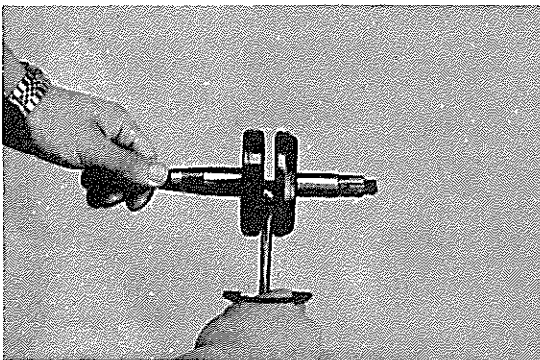

Fig. 3-17-5

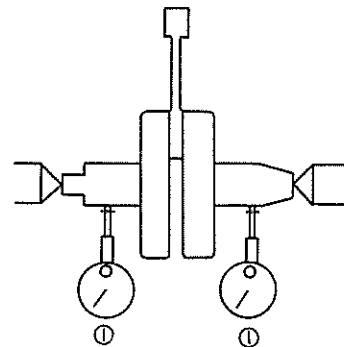

Fig. 3-17-6

3-18 Bearings and Oil Seals

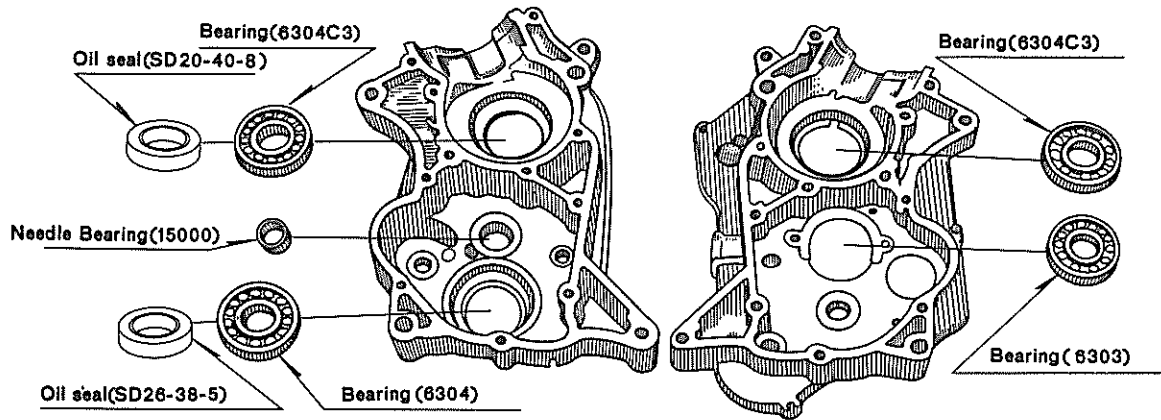

Fig. 3-18-1

1. Removal and Installation

1) Removal

- a. Pry the oil seals out of place with a slot head screwdriver. Always replace the oil seals when overhauling the engine.

(⊖ Screw driver)

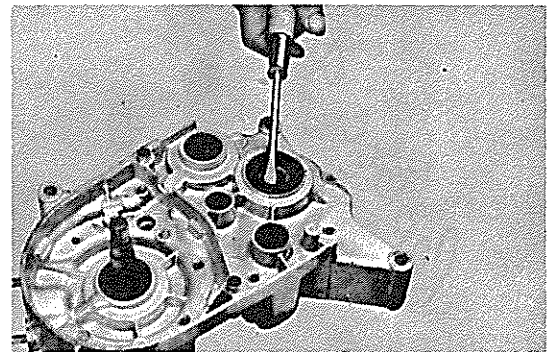

Fig. 3-18-2

- b. Drive out the bearing with a bearing tool. (It is preferable to heat the case to approximately 120°C (250°F) to remove bearings).

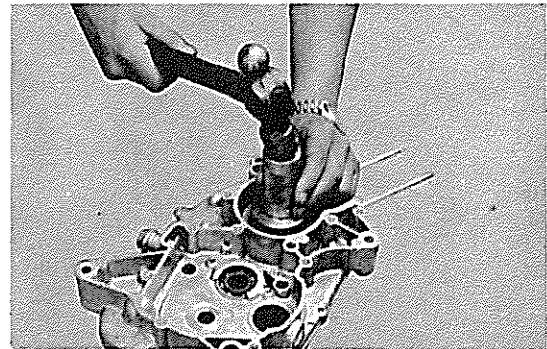

Fig. 3-18-3

2) Installation

Install bearings and oil seals with their stamped manufacturer's marks or numerals facing outward (In other words, the stamped letters must be on the exposed view side.)
When installing bearings, pack them with grease.

3-19 Carburetor

The JT is equipped with a Y16P 16 mm Venturi carburetor that is equipped with a built-in starter jet.

CARBURETOR

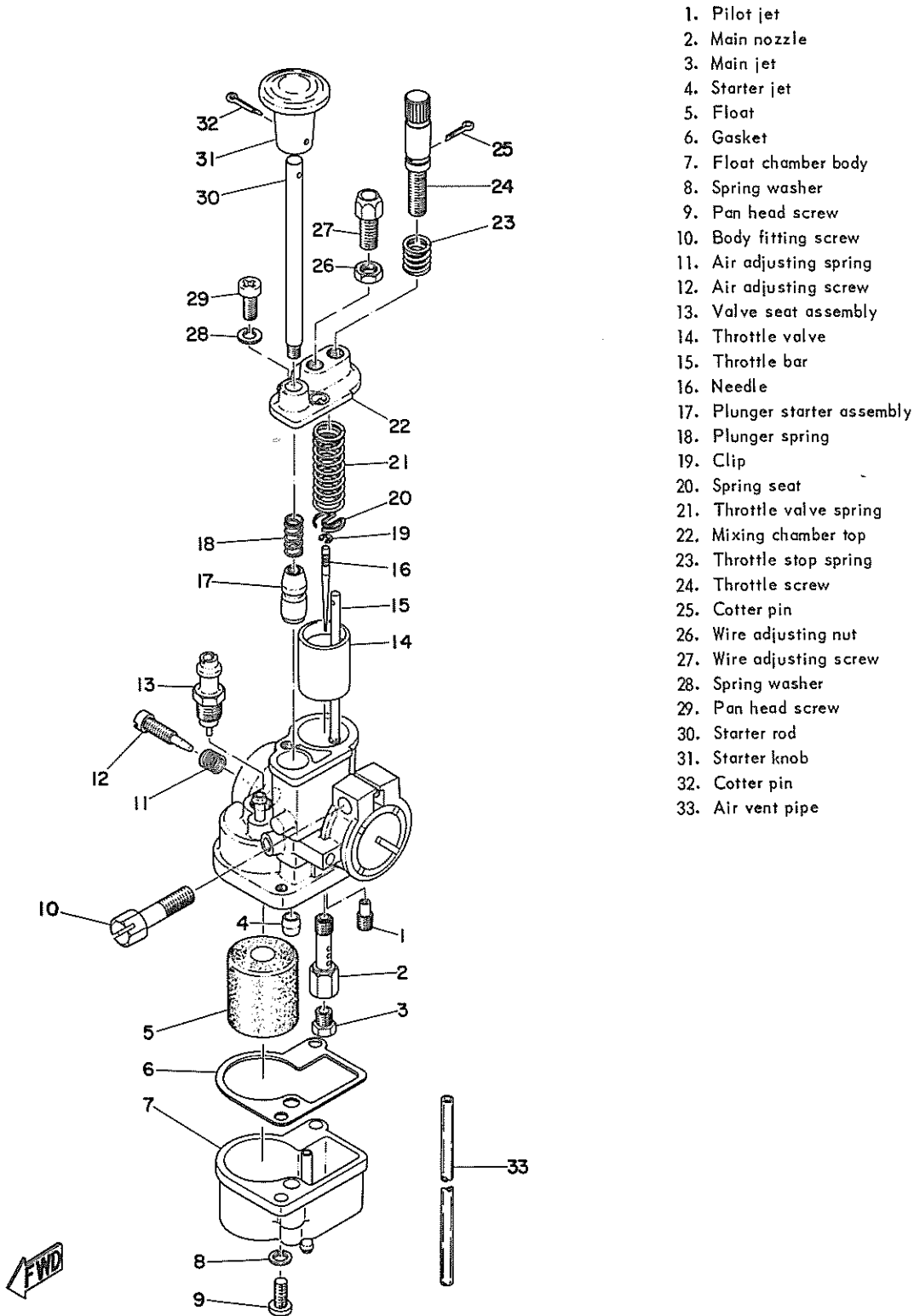

1. Pilot jet
2. Main nozzle
3. Main jet
4. Starter jet
5. Float
6. Gasket
7. Float chamber body
8. Spring washer
9. Pan head screw
10. Body fitting screw
11. Air adjusting spring
12. Air adjusting screw
13. Valve seat assembly
14. Throttle valve
15. Throttle bar
16. Needle
17. Plunger starter assembly
18. Plunger spring
19. Clip
20. Spring seat
21. Throttle valve spring
22. Mixing chamber top
23. Throttle stop spring
24. Throttle screw
25. Cotter pin
26. Wire adjusting nut
27. Wire adjusting screw
28. Spring washer
29. Pan head screw
30. Starter rod
31. Starter knob
32. Cotter pin
33. Air vent pipe

Fig. 3-19-1 Explosion diagram of carburetor

A. Checking the Carburetor

1) Float

Remove the float and shake it to check if gasoline is inside. If fuel leaks into the float while the engine is running, the float chamber fuel level will rise and make the fuel mixture too rich. Replace the float if it is deformed or leaking. Do not try to solder a leaking float.

2) Float valve

Replace the float valve if its seating end is worn with a step or if it is scratched. Check the float valve spring for fatigue. Depress the float valve with your finger, and make sure that it properly seats against the valve seat. If the float valve spring is weakened, fuel will overflow, flooding the float chamber while the gas is on.

3) Overflowing

If fuel overflows, check the carburetor as described in 1) and 2) above. If neither 1) nor 2) cures the overflowing, it may be caused by dirt or dust in the fuel preventing the float valve from seating properly. If any dirt or dust is found, clean the carburetor, petcock and gas tank.

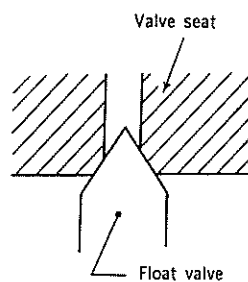

Fig. 3-19-2

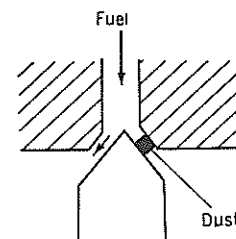

Fig. 3-19-3

4) Cleaning the carburetor

Disassemble the carburetor, and wash all its parts in a suitable solvent.

Then blow all the parts off with compressed air. All jets and other delicate parts should be cleaned by blowing compressed air through them after the float bowl has been removed.

B. Idle Mixture-Idle Speed Adjustments

The idle Mixture adjustment should be set exactly to factory specifications. First, turn the air screw in until it lightly seats then back it out $1\frac{1}{2}$ turns. Next, adjust the throttle stop so that the engine idles at 1250~1350 rpm.

ENGINE - Air Cleaner

C. CARBURETOR SETTING TABLE

	JT1	JT1	JT1L	JT2	JT2	JT2M
Type/Mfr.	Y16P Teikel	←	←	←	←	←
Identification	288E1	←	←	288E2	288E3	288E3
Main Jet	No. 86	←	No. 84	No. 80	No. 84	←
Needle Jet	2.085	←	←	2.080	←	←
Jet Needle	032-2	←	←	035-3	←	←
Cut Away	1.5	←	←	←	←	←
Pilot Jet	No. 38	←	←	←	←	←
Air Screw (turns out)	1½	←	←	1½	1½	←
Starter Jet (G.S.)	No. 50	←	←	←	←	←
Engine Number	000101 ~	016139 ~	200101 ~	050101 ~	053801 ~	300101 ~
Identification Mark	None	"Y" on Float Bowl*	←	None	None	None

*Vent diameter changed.
 NOTE: Best performance = E3 settings — Do not use Main Jets smaller than No. 82!

Float Level

With the float bowl removed, note the location and condition of the inlet needle seat on the top of the float. If it is in good condition, float level will be correct. This is due to the fact that as fuel level increases the float is raised until it touches and then shuts off the inlet needle. There is no float arm or shut-off tang as found on other Yamaha models.

3-20 Air Cleaner

This model is equipped with a reusable, oil impregnated, foam air filter. It must be removed and cleaned at least once a month, and more often if the motorcycle is ridden mainly in the dirt (preferably each time after you spend the entire day in the dirt (8-10 hours operation)).

- 1) Remove the air cleaner mounting bolt and loosen the air cleaner. (JT2-JT2M)

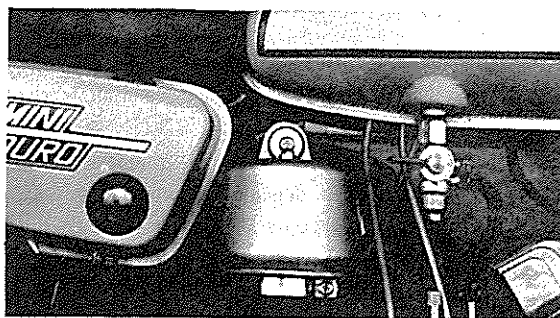

Fig. 3-20-1

- 2) Remove the air cleaner case cap. (JT2-JT2M)

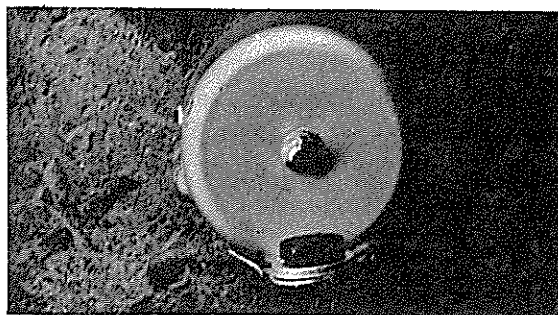

Fig. 3-20-2

- 3) The cleaner element can be pulled out.
(JT2--JT2M)

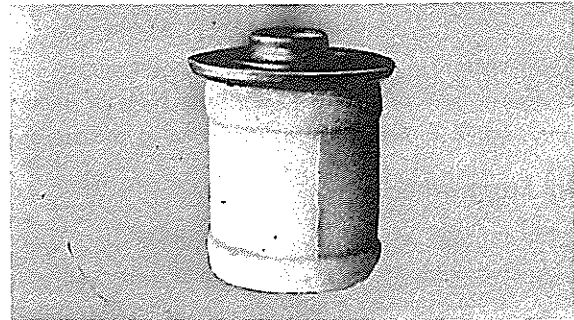
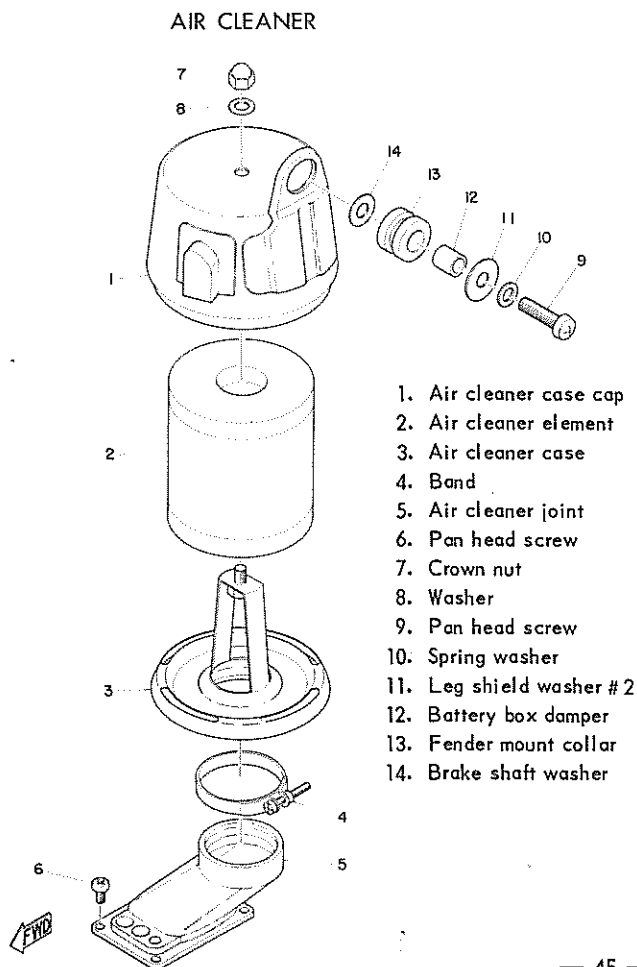

Fig. 3-20-3

B. Cleaning

The element is of the wet type made of foam rubber and is oiled so that its dust removal efficiency and service life are greatly improved compared with a conventional paper element. Accordingly it is advisable that the element be washed in solvent mixed with oil (10:1). After washing, shake off the excess solvent and install the element in the case. Never allow the element to dry out as its efficiency will be greatly reduced.

JT2



JT1

1. Air cleaner case
2. Air cleaner case cap
3. Air cleaner element
4. Air cleaner joint
5. Pan head screw

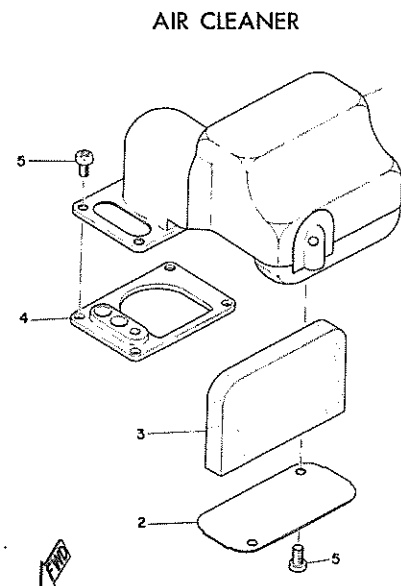

Chapter 4 Chassis

The Yamaha JT has been designed for versatility and a combination of uses. This machine has been engineered to have a minimum weight factor. Yet with the reduction in weight, rigidity, strength, and safety have been incorporated in the design of the frame to provide an unexcelled machine.

4-1 Front Wheel

The 15" front wheel is equipped standard with a 2.50-15" Trials Universal tire. This tire gives the rider assurance of maximum performance and safety for both road riding and trail riding. The front wheel brake size is 110 mm x 25 mm (4.33 x 0.98 in). A labyrinth seal is installed between the wheel hub and brake plate to provide a seal against dust and water.

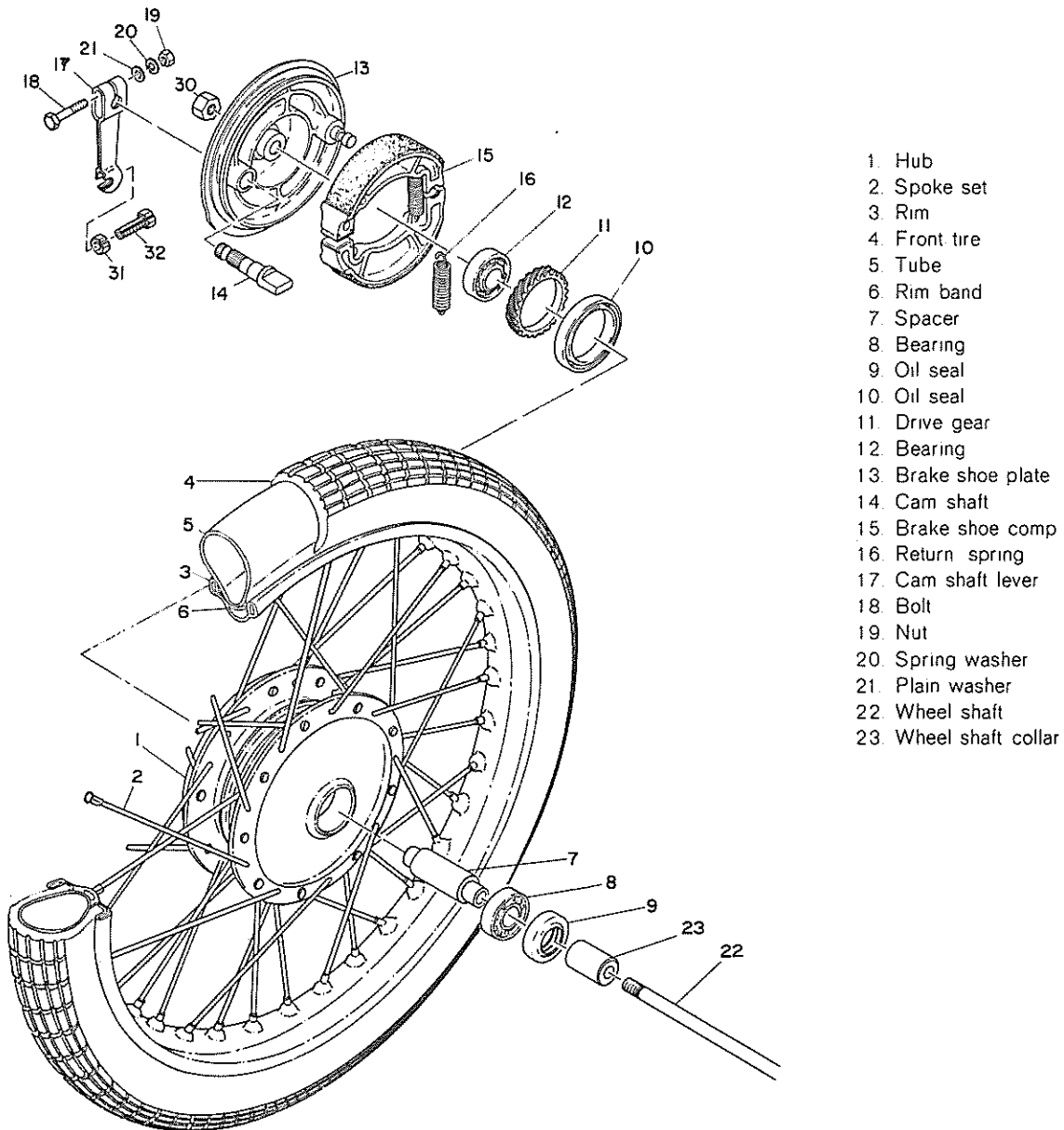

Fig 4-1-1

A. Removal

- 1) Disconnect the brake cable from the front wheel hub plate.

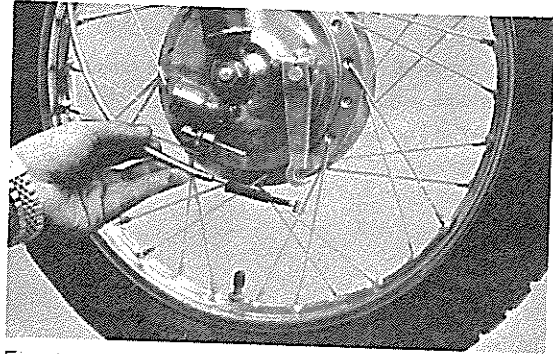

Fig. 4-1-2

- 2) Remove the front wheel nut.
(17 mm)

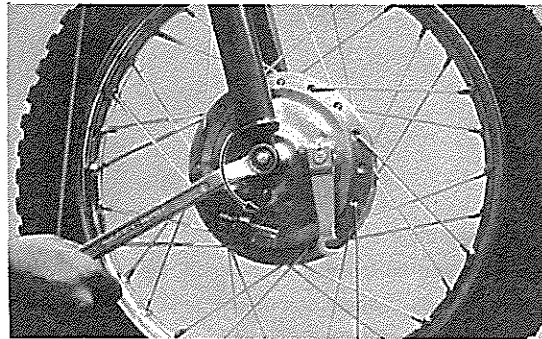

Fig. 4-1-3

- 3) Pull out the front wheel shaft. Take care not to lose the distance collar, as it will come loose when the shaft is removed.

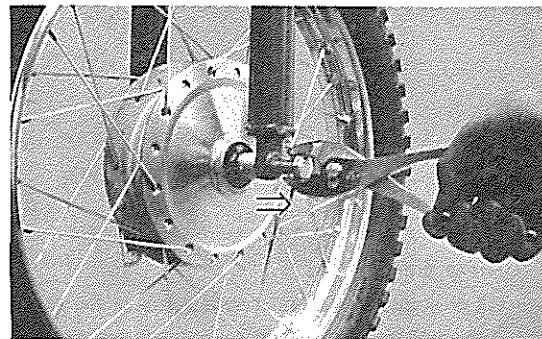

Fig. 4-1-4

- 4) Raise the front of the machine and set it on a box. Then remove the wheel assembly.

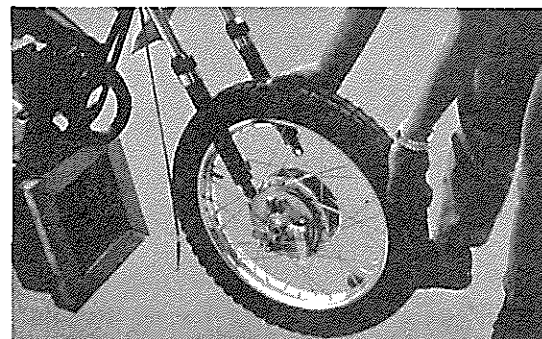

Fig. 4-1-5

B. Checking

1) Run out of the rim

As shown in Fig. 4-1-6, measure the runout of the rim with a dial gauge. Run out limits: 2 mm. (0.07 in.) or less.

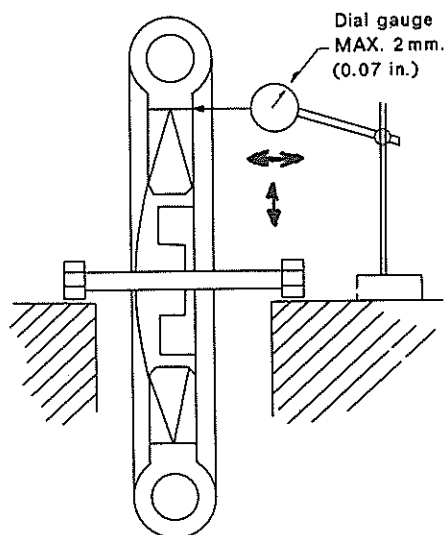

Fig. 4-1-6

2) Brake shoe

Measure the outside diameter at the brake shoe with slide calipers. If it measures less than 104 mm. (4.09 in.) replace it.

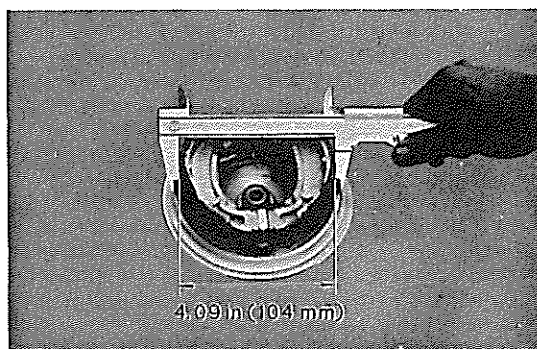

Fig. 4-1-7

3) Brake drum

Oil or scratches on the inner surface of the brake drum will impair braking performance or result in abnormal noises. Clean or smooth out the surface with a rag soaked in lacquer thinner or with sandpaper.

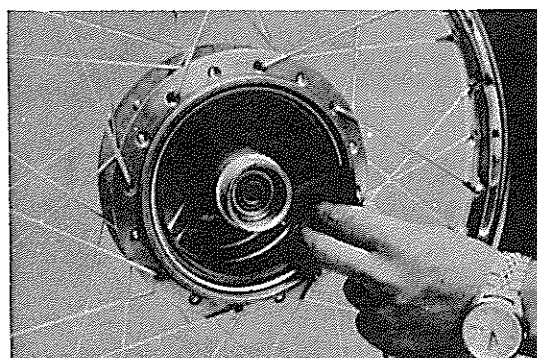

Fig. 4-1-8

4) Check the spokes. If they are loose or bent, replace or tighten them. If the machine is ridden in rough country often, or raced, the spokes should be checked regularly.

5) Repairing the brake shoe

If the brake shoe has uneven contact with the brake drum or scratches, smooth out the surface with sandpaper or hand file. If the surface is glazed use the file to remove the hard smooth finish.

6) If the tire is excessively worn, replace it.

7) Regularly check the tires for damage.

8) If the bearings allow excessive play in the wheel or if it does not turn smoothly, replace the bearing.

9) Replace a bent or damaged front wheel axle.

10) Check the lips of the seals for damage or warpage. Replace if necessary.



Fig. 4-1-9

Replacing the Wheel Bearing

a. First clean the outside of the wheel hub.

b. Insert the bent end of the special tool (as shown in Fig. 4-1-11) into the hole located in the center of the bearing spacer, and drive the spacer out from the hub by tapping the other end of the special tool with a hammer. (Both bearing spacer and spacer flange can easily be removed.)

c. Then push out the bearing on the other side.

d. To install the wheel bearing, reverse the above sequence. Be sure to grease the bearing before installation and use the bearing fitting tool (available from Yamaha.)

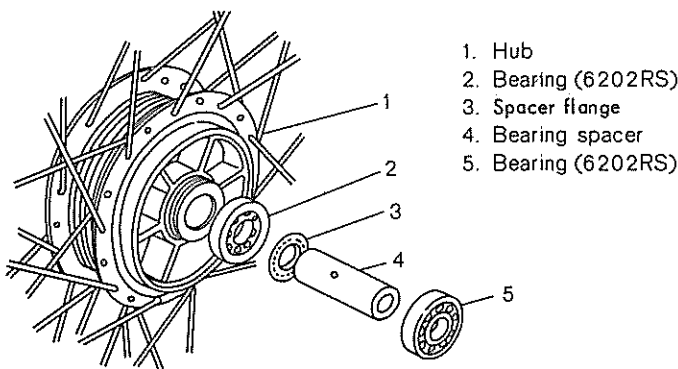
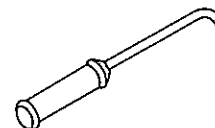

Fig. 4-1-10



Insert the bent end of the special tool into the hole located in the center of the bearing spacer.

Fig. 4-1-11

4-2 Rear Wheel

The rear wheel is 15-in. size, and the rear tire is the 2.50-15 Trials Universal. The single leading shoe type brake is 130 mm. x 28 mm. (5.12 x 1.10 in.) in size. A labyrinth seal between the wheel hub and the brake plate is provided to prevent water and dust leakage. The brake tension bar is of link design to minimize the shifting of the brake cam lever position when the rear swing arm is moving up and down.

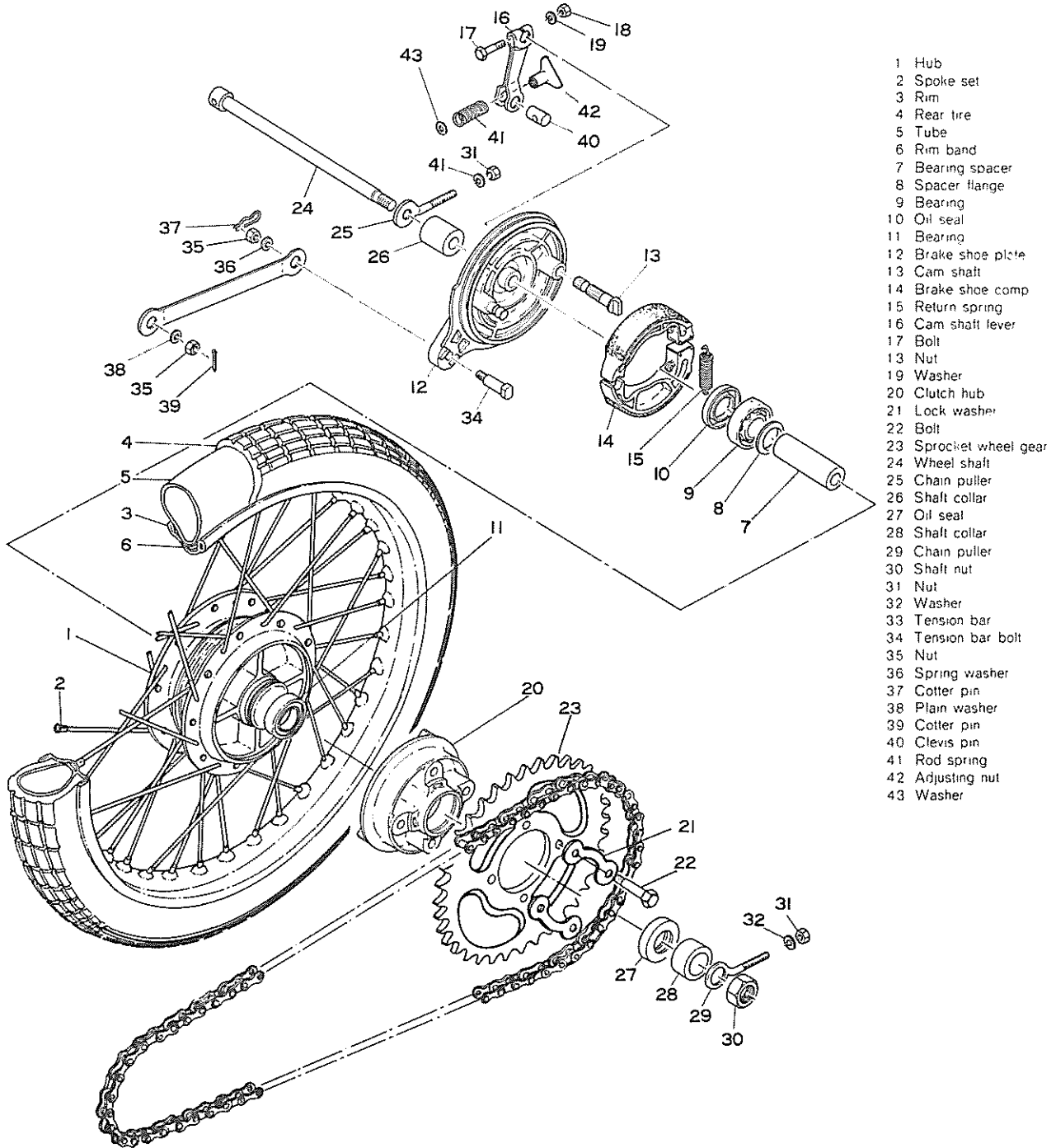

Fig. 4-2-1 Rear Wheel Construction

A. Removal

- 1) Remove the tension bar and brake rod from the rear shoe plate.

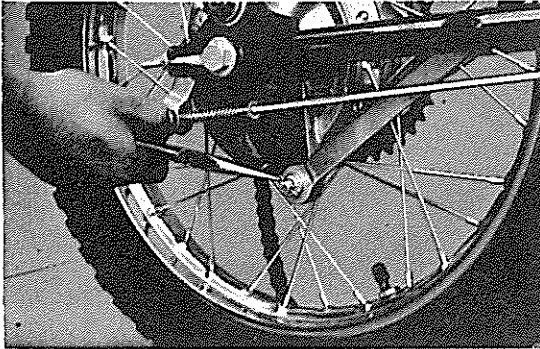

Fig. 4-2-2

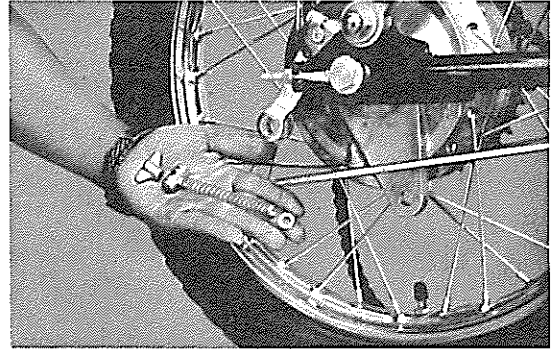

Fig. 4-2-3

- 2) Loosen the chain tension adjusting nut and bolt on both right and left sides.
(10 mm)

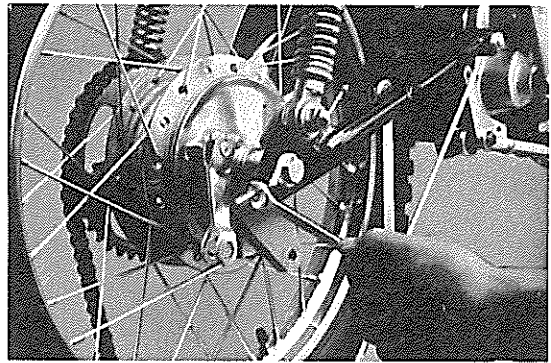

Fig. 4-2-4

- 3) Remove the rear wheel shaft nut.
(19 mm)

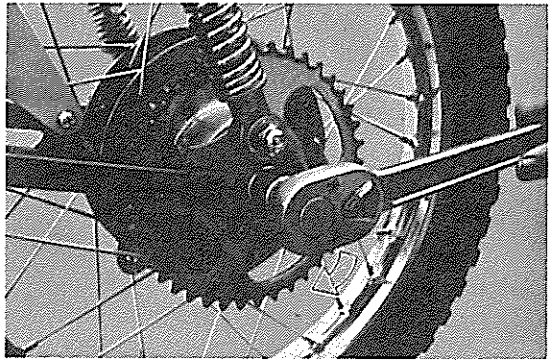

Fig. 4-2-5

- 4) Pull out the rear wheel shaft by striking it with a soft-faced hammer.

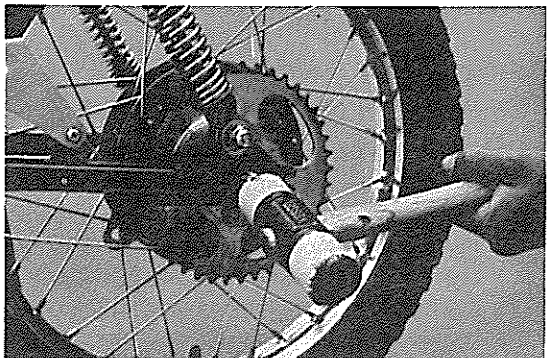

Fig. 4-2-6

5) Remove the right-hand chain adjuster and distance collar.

Remove the axle.

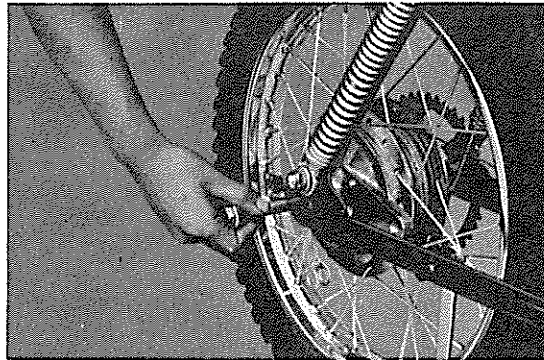

Fig. 4-2-7

6) Remove the rear brake plate.

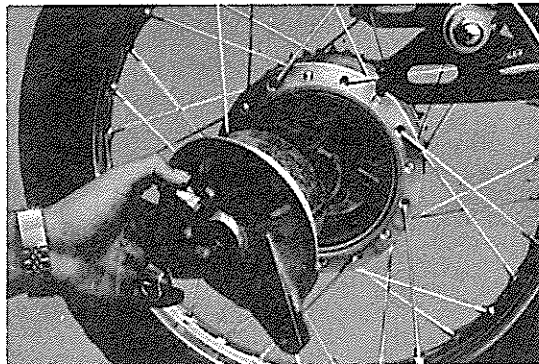

Fig. 4-2-8

7) Lean the machine to the left and remove the rear wheel assembly.

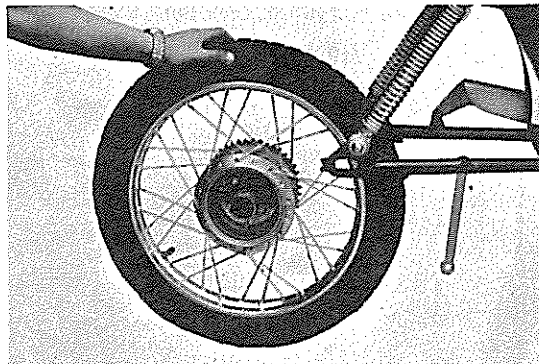

Fig. 4-2-9

Replacing the Wheel Bearing

Replace the rear wheel bearing in the same way as the front wheel bearing.

1) Tire and Tube Removal and Installation

- a) Whether it is the front tire or the rear tire to be changed, the procedure of tire and tube removal is identical. The explanation that follows is the proper method for both wheels.
- b) Remove the valve cap, valve stem, and valve stem lock nut. Use two tire irons (with rounded edges) and begin to work the tire bead over the edge of the rim, starting opposite the tube stem. Take care to avoid pinching the tube. After one bead of the tire has been completely worked off the rim, slip the tube out. Be very careful not to damage the stem as it is pushed back out of the rim hole.

- c) If the tire is to be completely removed, then work the tire off the same rim edge.
- d) Installing the tire can be accomplished by reversing the disassembly procedure. The only difference in procedure would be to inflate the tube momentarily before both tire edges have been completely slipped onto the rim. This removes any creases that might exist. After the tire has been completely slipped onto the rim, check to make sure that the stem is squarely in the center of the hole in the rim. Then inflate the tube to 40 + psi several times. Check for leaks, and set at prescribed pressure.

B. Inspection

- 1) Run out of the rim
Check the rim for run out in the same way as the front wheel. Maximum limit of runout.....2 mm.(0.07 in.) or less.
- 2) Brake shoe
Check the brake shoe in the same way as the front wheel. Wear limit.....124mm. (4.9 in.)
- 3) Brake drum
Check the brake drum in the same way as the front wheel.
- 4) The spokes are measured in the same way as the front wheel. A loose spoke should be tightened.
- 5) If the bearing has excessive play or it does not turn smoothly, replace it.
- 6) If the tire or the pattern is worn out, replace the tire.
- 7) If the lip of the oil seal is damaged or warped, replace it.

4-3 Rear Wheel Sprocket

A. Checking and Adjustment

The rear wheel sprocket is installed on the clutch hub. To replace the sprocket, take the following steps.

- 1) Removing the sprocket
 - a. Bend the lock washer ears flat.
(flat chisel)

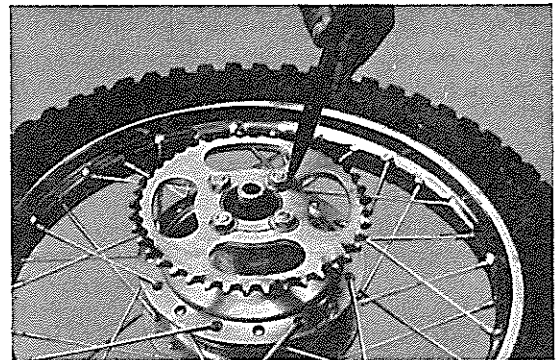

Fig. 4-3-1

- b. Remove the sprocket mounting bolts.
(14 mm)

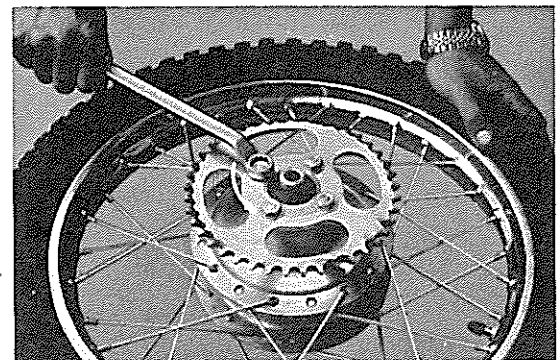

Fig. 4-3-2

2) Checking

Check the lock washer and hexagonal bolt for breakage and damage. If the lock washer is not bent, over the hexagon bolt head, or is broken, or if the bolt is loose, the sprocket can come loose. Make sure that both lock washers and the mounting bolts are tight

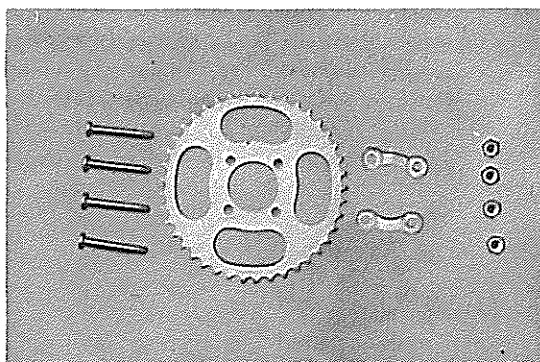

Fig. 4-3-3

Drive Chain Adjustment

To adjust drive chain, proceed as follows:

1. Loosen rear axle securing nut.
2. With rider in position on machine, both wheels on ground, set axle adjusters until there is 3/4 to 1 inch slack in the drive chain at the bottom of the chain at a point midway between the drive and driven axles.
3. Turn adjusting nuts in or out to obtain correct free play, and at the same time insure that both ends of axle are positioned evenly. This can be checked by utilizing the marks on end of swing arms and notch cut into top of adjusting bolt.

Tighten the rear axle securing nut.

Axle Nut Torque: 4.5 – 5.0 kg-m (400 – 440 in.-lbs.)
--

4-4 Tires and Tubes

1) Normal tire pressure

Though tire pressure is the rider's choice, the standard tire pressure is as follows:

Front 22.4 lbs./in²(1.6 kg./cm²)

Rear 28.0 lbs./in²(2.0 kg./cm²)

When the tire pressure is reduced below the specified amount because of some reason, the tire may slip around the rim and destroy the valve stem (unless rim locks are installed).

4-5 Front Fork Removal

1) Remove the inner tube cap bolt.

(17 mm)

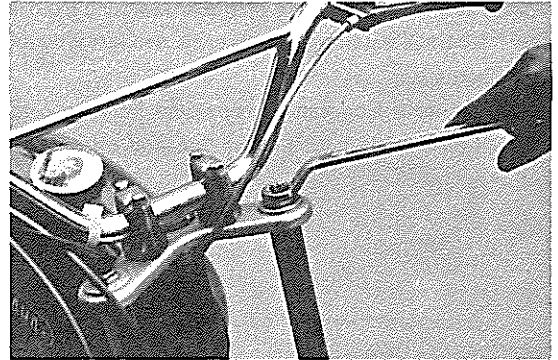

Fig. 4-5-2

3) Loosen the inner tube pinch bolt on the under-bracket.

(14 mm)

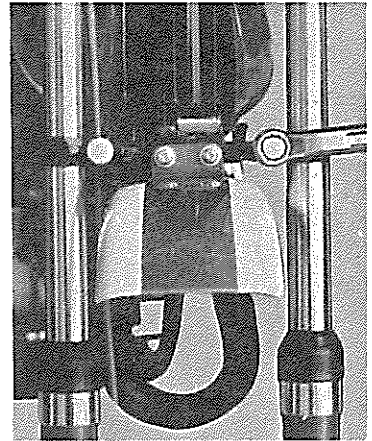

Fig. 4-5-3

4) Pull the outer tube downward.

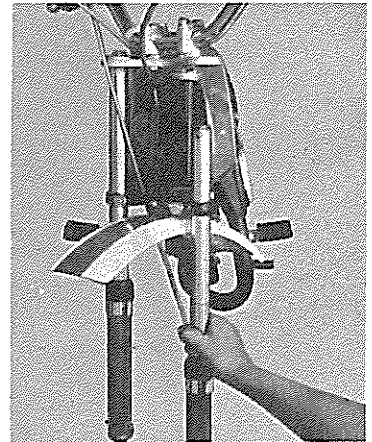

Fig. 4-5-4

B. Disassembling the Inner and Outer Tubes

1) Drain the oil from the fork

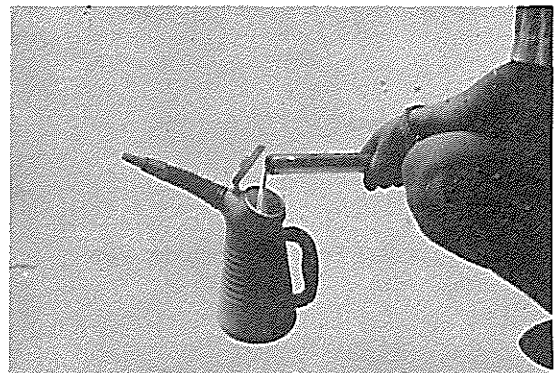

Fig. 4-5-5

CHASSIS-Front Forks

2) Place a rubber sheet or tire tube around the outer tube nut, install a strap wrench, and turn it counter clockwise.

The inner tube can be separated from the outer tube once this tube nut is threaded off.

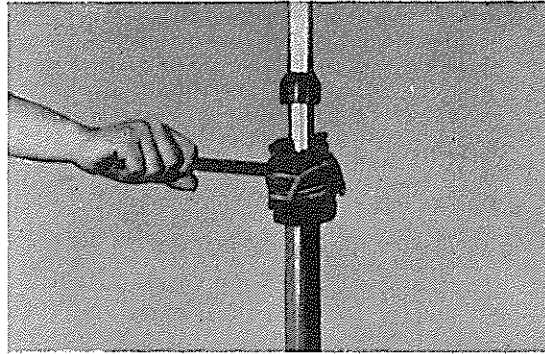
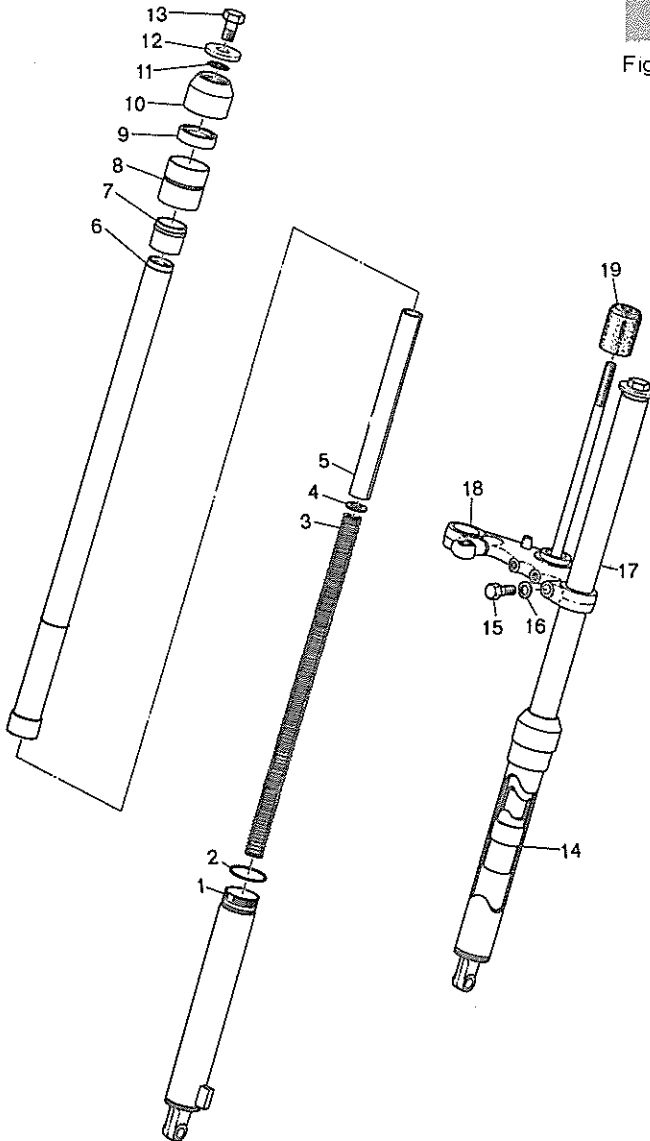

Fig. 4-5-6



1. Outer right tube
2. O-ring
3. Fork spring
4. Spring upper washer
5. Spacer
6. Inner right tube
7. Slide metal
8. Outer nut comp
9. Oil seal
10. Dust seal
11. Packing
12. Cap washer
13. Cap bolt
14. Outer left tube
15. Underbracket bolt
16. Spring washer
17. Inner left tube
18. Underbracket comp
19. Front fork guide

Fig. 4-5-7 Front Fork Exploded View

C. Checking

1) Inner tube

Check the inner tube for bends or scratches. If the bend is slight, it can be corrected with a press. It is recommended, however, to replace the tube if possible.

2) Oil seal

When disassembling the front fork, replace the oil seal in the outer tube nut.

D. Assembling

1) When assembling the front fork, reverse the order of disassembly. Check if the inner tube slides in and out smoothly.

2) Installing the front fork on the frame

a. Bring up the front fork to the correct position and tighten the underbracket pinch bolt slightly. Fill the fork tube with oil (see below) and tighten the cap bolt thoroughly. Then tighten the pinch bolts completely.

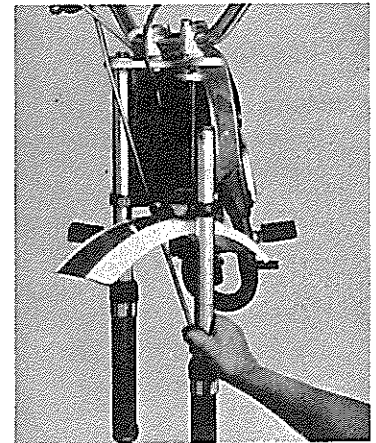

Fig. 4-5-8

b. Pour oil into the inner tube through the upper end opening. Front fork oil:

Yamaha shock fluid Right 97 cc (3.3 fl. oz)

Left 120 cc (4.1 fl. oz)

c. Install the cap bolt.

4-6 Rear Snocks

The rear shocks have a maximum stroke of 55 mm.(2.16 in.)

A. Checking the Condition of the Damping Units.

1) Remove the rear shock assembly.

(17 mm)

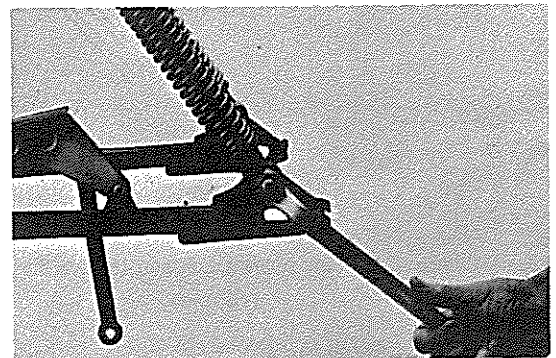

Fig. 4-6-1

CHASSIS - Gas Tank, Rear Swing Arm

- 2) Make sure that the rear cushion moves up and down completely from bottom to top.

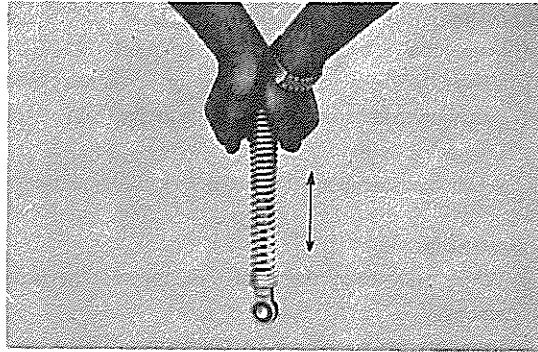

Fig. 4-6-2

4-7 Gas Tank

A. Removing

- 1) Pull out the seat fitting pin and remove the seat by pulling it backward.

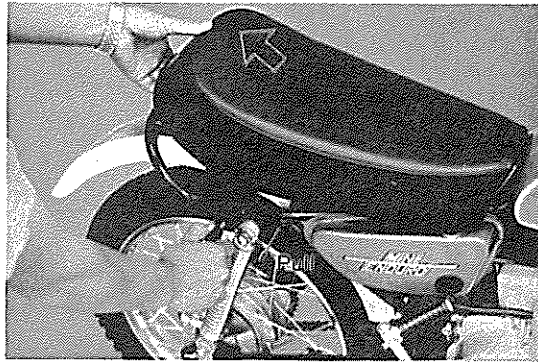

Fig. 4-7-1

- 2) Set the petcock lever at the "Stop" position and disconnect the fuel line at the petcock.

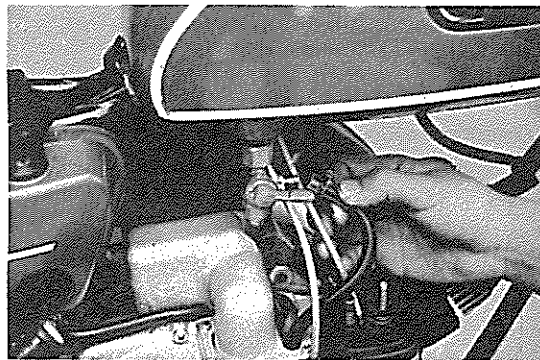

Fig. 4-7-2

- 3) Next, remove the tank holding bolt and remove the tank by pulling it backward.
(13 mm)

4-8 Rear Swing Arm

The rear swing arm is made of steel tubing that improves the strength and torsional rigidity. The pivot employs permanently lubricated bearings.

A. Removing

- 1) Remove the two chain case mounting bolts.
(⊕ Screw driver)

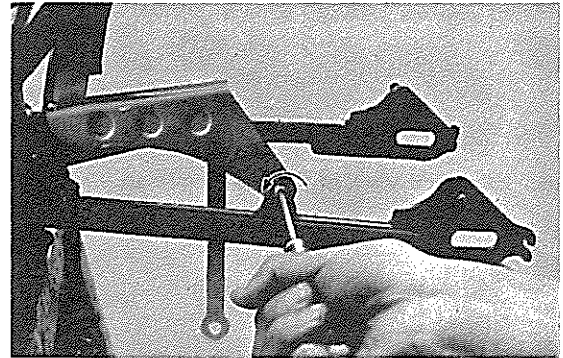

Fig. 4-8-1

- 2) Remove the rear swing arm shaft nut, pull out the shaft, and remove the rear swing arm.
(17 mm)

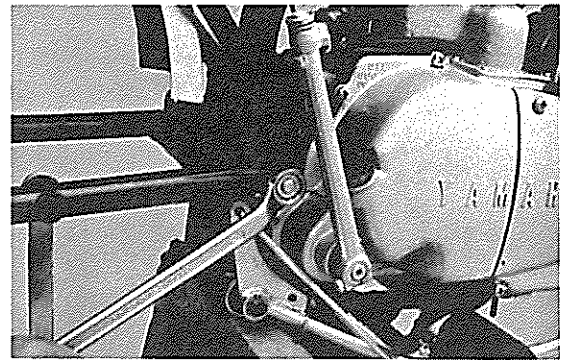

Fig. 4-8-2

B. Checking

- 1) Check the play of the rear swing arm by shaking it as show in Fig. 4-8-3, with the rear swing arm installed.
If the play is excessive, replace the rear swing arm bushing or the rear swing arm shaft.
- 2) Insert the bushing as indicated in Fig. 4-8-4, and check it for play. If the play is excessive, replace the bushing.

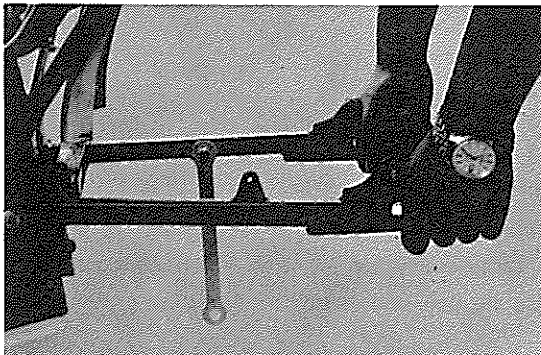

Fig. 4-8-3

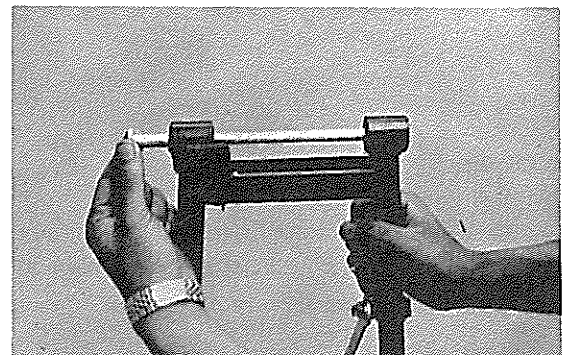

Fig. 4-8-4

- 3) Grease the rear arm shaft periodically.

Replacing Rear Swing Arm Bushings

Replacement should be made according to machine condition such as excessive play of the rear swing arm, or hard steering (wander, shimmy or rear wheel hop.) or upon request of the customer.

EXPLODED VIEW

4-9 Steering Head

A. Exploded View of the Steering Head

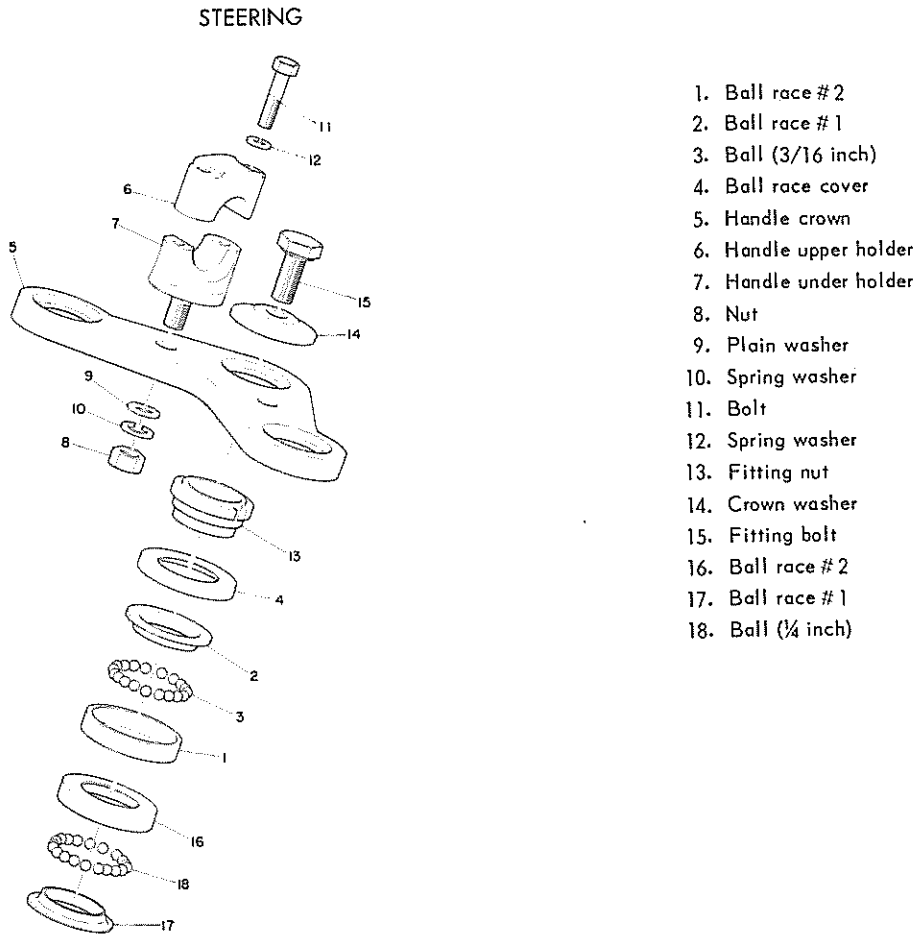

Fig 4-9-1

B. Checking

1) Ball Races and Steel Balls

Check the ball races and steel balls for pitting or wear. Check them very carefully if the machine has been in long use. If any are worn or cracked, replace all of them, because defective ball races or steel balls adversely affect the maneuverability of the machine. Clean and grease the balls and races periodically.

Note: Do not use a combination of new balls and used races or vice versa. If any of these are found defective, replace the whole ball and race assembly.

4-10 Oil Tank, and Tool Box

The oil tank is located on the right side under the seat. It is designed to be as narrow as possible so that it will not contact the rider's lower limbs when he stands upright on the footrests. To fill the autolube oil tank, lift the seat and the tank cap will be exposed. Oil tank capacity.....1.0 litres.(1.1 u. s qts)

4-11 Frame

The double cradle-type frame is made of high tension steel tubes that provide strength, rigidity and light weight. Other dimensional features include high ground clearance, narrow width, and long wheelbase. The engine is bolted to the frame at three positions. The caster is measured at 63.50° .

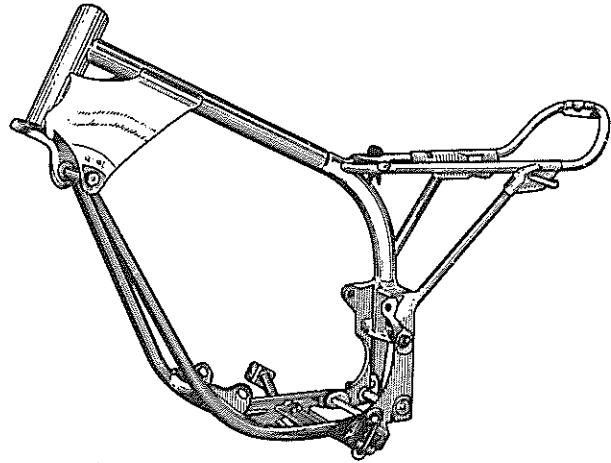

Fig. 4-11-1

4-12 Handlebars

The upswept type longer handlebars are ideal for leverage on rough terrain and are provided with deep-cut pattern grips to prevent hand slippage.

4-13 Miscellaneous

The footrest is made of a single steel tube extending under the lower part of the frame, and bolted to the frame. The engine guard is bolted to the frame to protect the entire crankcase.....covering from the exhaust system to the drain plug.

CHAPTER 5. ELECTRICAL

5-1 Electrical Equipment

Equipment

The Yamaha JT2 is equipped with a flywheel, silicon rectifier and 6-volt, 2 amp/h battery. The JT1 has no lighting equipment. The JT1L has lights only.

5-2 List of Electrical Components

JT1

Parts	Manufacturer	Model & Type
Flywheel magneto	Hitachi Ltd.	F11-L42
Spark plug	NGK	B-7HS

JT2

Engine:		
Flywheel magneto	Hitachi	F11-L46
		Sparking
		7mm or more/500 rpm
		8mm or more/5,000 rpm
		Charging
		0.4 A or more/2,500 rpm
		4 A or less/8,000 rpm
		Lighting / (load = 21.8W)
		5.6 V or more/2,500 rpm
		7.8 V or less/8,000 rpm
Spark plug	NGK	B-8HS
Neutral switch	Asahi Elec.	YNS type
Frame:		
Battery	GS	6N2-2A-3 6V 2AH
Main switch	Asahi Elec.	
Silicon rectifier	Fuji Elec.	
Horn	Nikko	GF-6
Ignition coil	Hitachi Elec.	CM61-50
Fuse holder	Mitsuba Elec.	10A, 2 pcs.
Front End:		
Headlight	Koito Elec.	6V 15W/D
Speedometer	Nippon Seiki	Neutral light 6V 3W Meter light 6V 1.5W
Rear End:		
Taillight (stop light)	Imasen Elec.	6V 5.3W/17W
Stop switch	Asahi Elec	

NOTE: See Appendices for JT1L components.

5-3 Ignition System—Function and Service

1. Function

The ignition system consists of the components as shown in Fig. 5-3-1. As the flywheel rotates, the contact breaker points begin to open and close, alternately. This make-and-break operation develops an electromotive force in the ignition power source coil, and produces a voltage in the ignition coil primary windings. The ignition coil is a kind of transformer, with a 1:50 turn ratio of the primary to the secondary winding. The voltage (150-300 V) which is produced in the primary coil, is stepped up to 12,000-14,000 V by mutual-induction, and the electric spark jumps across the spark plug electrodes.

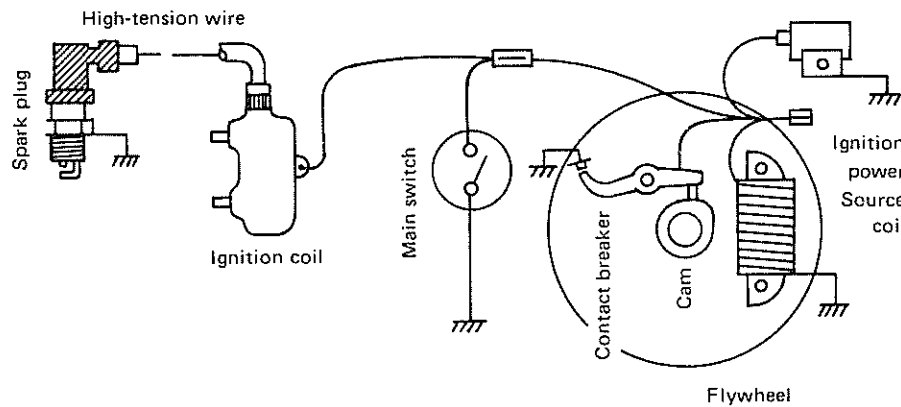

Fig. 5-3-1

5-4 Ignition Timing

Remove the spark plug and screw the dial indicator holder into the plug hole. Next, insert the dial indicator into the holder. Bring the piston up to T.D.C. and set the zero on the dial face to line up exactly with the dial indicator needle. The crankshaft should then be turned backwards, so that the piston travels down past 1.8 mm B.T.D.C. and slowly brought back up to precisely 1.8 mm B.T.D.C. (This removes any slack).

Adjust the points so that they are just beginning to open with the piston in this position. A low resistance point checker (100 Ohms or less) should be used to determine the opening and closing of the ignition points.

Ignition Timing, 1.8 mm. B.T.D.C.

Maximum ignition point gap 0.3 to 0.4 mm. (0.012"-0.015")

5-5 Ignition Coil

Primary coil resistance value $4.9 \Omega \pm 10\%$ (20°C or 68°F)
 Secondary coil resistance value $.11 \text{ K}\Omega \pm 10\%$ (20°C or 68°F)
 (For measuring methods, refer to Fig. 5-5-1)

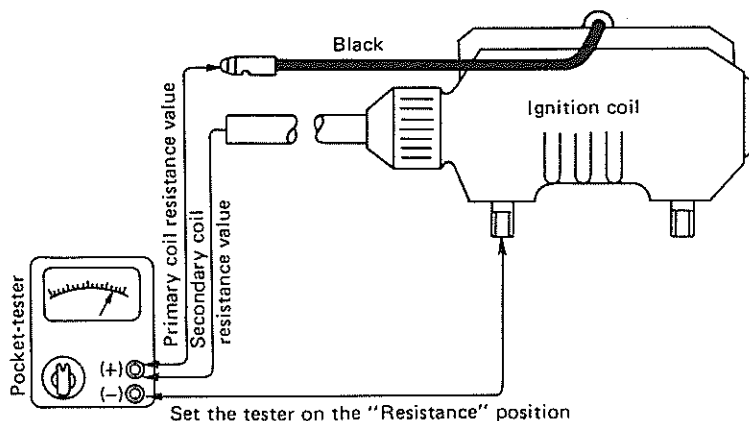

Fig. 5-5-1

Note: When measuring the secondary coil resistance value, disconnect the plug cap. Otherwise, the resistance of the $5\text{K}\Omega$ noise suppressor incorporated in the plug will be added to the tester reading.

Spark Test:

Remove spark plug from cylinder head and reconnect the high voltage lead. Then hold the spark plug approximately 7 mm away from the head and see if it sparks as you crank the kickstarter.

If it sparks at 7 mm. or so, and has blue white color, the ignition coil should be considered to be in good condition.

5-6 Condenser

The condenser instantly stores a static electric charge as the contact breaker points separate, and the energy stored in the condenser discharges instantly when the points are closed. If it were not for the condenser, an electric arc would jump across the separating contact points, causing them to burn.

Burned contact points greatly affect the flow of current in the primary winding of the ignition coil.

If the contact points show excessive wear, or the spark is weak (the ignition coil is in good condition), check the condenser.

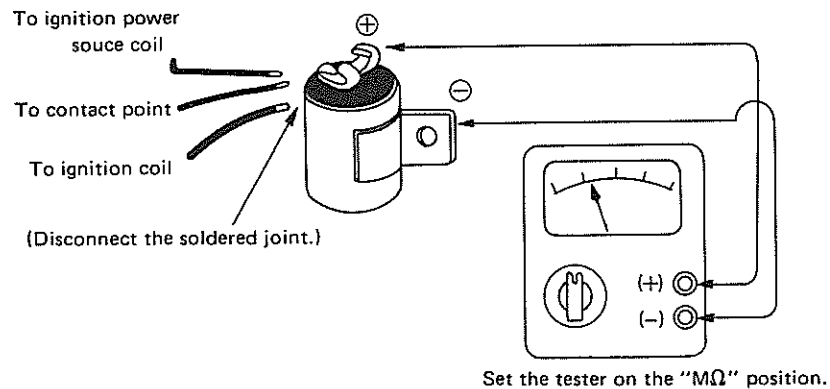

Fig. 5-6-1

Insulation resistance tests should be conducted by connecting the tester as shown in Fig. 5-6-1; If the pointer swings fully and the reading is more than $3M\Omega$, the insulation is in good condition. If the insulation is faulty, the pointer will stay pointing at the uppermost reading, indicating very little resistance.

Note: After this measurement, the condenser should be discharged by connecting the positive and negative sides with a thick wire.

Capacity tests can be performed by simply setting the tester to the condenser capacity. The tester should be connected with the condenser in the same way as in the case of the insulation resistance test. Before this measurement, be sure to set the tester correctly.

If the reading is within $0.22\mu F \pm 10\%$, the condenser capacity is correct

5-7 Charging System (JT2—See Appendices for JT1L information.)

The charging system consists of the flywheel magneto (charging and lighting coils), rectifier, and battery.

1. Flywheel Magneto

As the flywheel rotates, an alternating current is generated in the charging and lighting coils and converted to a half-wave current by means of a silicon rectifier. This half-wave current is charges battery.

Charging Capacity (Daytime)

Green lead: Charging begins at 2,500 r.p.m.	} JT2
0.4 A or more at 2,500 r.p.m.	
4.0 A or less at 8,000 r.p.m.	

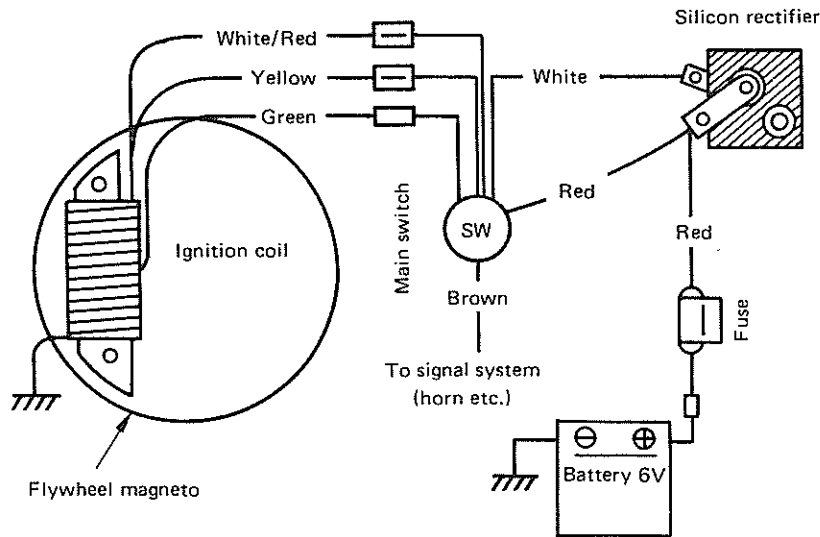

Fig. 5-7-1

Lighting Capacity (Night time)
 (With normal loads and normal wiring.)
 5.6V or more at 2,500 r.p.m. }
 7.8V or less at 8,000 r.p.m. } (JT2)

* The charging and lighting capacity is obtained when the battery is fully charged. If the battery is in a low state of charge and low in voltage, the charging rate will be not exactly the same as above. However, it is desirable that the figures are as close as possible.

2. Silicon Rectifier

The alternating current, which is generated by the flywheel magneto, is rectified and charged to the battery. For this rectification, a single-phase halfwave silicon rectifier is employed.

Characteristics: Rated output -4A. }
 Rate peak inverse withstand voltage 400 V. } (JT2)

Polarity:

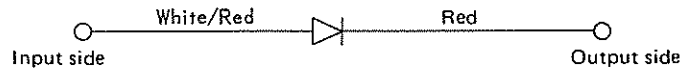

a. Checking the Silicon Rectifier

For measurements, an ohmmeter can be used.

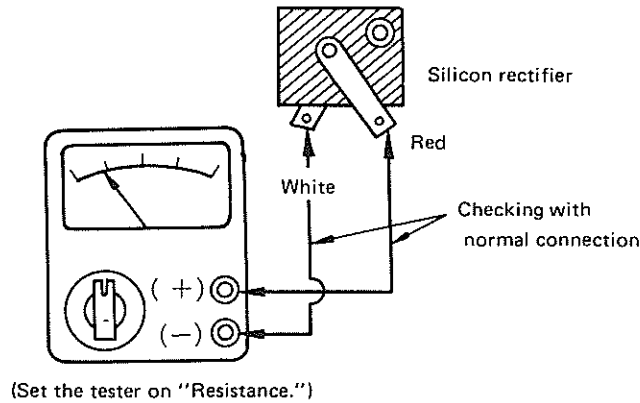

Fig. 5-7-2

Checking with Normal Connection

Connect the tester's red lead (+) to the silicon rectifier's red terminal, and connect the tester's black lead (-) to the rectifier's white terminal.

Standard value: $9-10\Omega$

If the tester's pointer will not swing back from the over scale, the rectifier is defective.

Checking with Reversal Connection

Connect the tester the other way round.

Standard value: If the pointer will not swing, the rectifier is in good condition. If the pointer swings, the rectifier is faulty.

3. Operational Note

The silicon rectifier can be damaged if subjected to overcharging. Special care should be taken to avoid a short circuit and or incorrect connection of the positive and negative leads at the battery. Never connect the rectifier directly to the battery to make a continuity check.

5-8 Battery - JT2

The battery is a 6 volt-2 AH unit that is the power source for the horn and stoplight. Because of the fluctuating charging rate due to the differences in engine R.P.M.s, the battery will lose its charge if the horn and stoplight are excessively used. The charging of the battery begins at about 2,500 R.P.M. Therefore, it is recommended to sustain engine R.P.M.s at about 2,500 to 3,500 R.P.M. to keep the battery charged properly.

1. Checking

- 1) If sulfation occurs on plates due to lack of the battery electrolyte, showing white accumulations, the battery should be replaced.
- 2) If the bottoms of the cells are filled with corrosive material falling off plates, the battery should be replaced.
- 3) If the battery shows the following defects, it should be replaced.
 - *The voltage will not rise to a specific value even after long hours charging.
 - *No gassing occurs in any cell.
 - *The 6V battery requires a charging current of more than 8.4 volts in order to supply a current at a rate of 1 amp. per hour for 10 hours.

2. Service Life

The service life of a battery is usually 2 to 3 years, but lack of care as described below will shorten the life of the battery.

- 1) Negligence in re-filling the battery with electrolyte.
- 2) Battery being left discharged.
- 3) Over-charging by rushing charge.
- 4) Freezing.
- 5) Feeding of water or sulfuric acid containing impurities when re-filling the battery.

3. Storage

If any motorcycle is not used for a long time, remove the battery and have it stored by a battery service shop. The following instructions should be observed by shops equipped with chargers.

- 1) Recharge the battery.
- 2) Store the battery in a cool, dry place, and avoid temperatures below 0°C. (32°F)
- 3) Recharge the battery before mounting it on the motorcycle.

4. Service Standards

Battery: 6N2-2A-3 (Nippon Battery)

Battery Spec.	6V-2AH	
Electrolyte-Specific gravity and quantity	1.25-1.27, 10 cc (1 cell)	At full charge
Initial charging current	0.2 A for 25 hours	Brand new motorcycle
Charging current	0.2 A for 13 hours (Charge until specific gravity reached 1.25-1.27)	When discharged
Refilling of electrolyte	Distilled water up to the max. level line.	Once a month

5-9 Checking the Main Switch (removed from the chassis) – JT2

Key "O" position

B–B/W

Key "I" Position

R–Br

G–W

Key "II" Position

R–Br

Br–L/W

R–L/W

W–G/R

Y–L

	B	B/W	R	Br	L/W	G	W	G/R	Y	L	
OFF	○—○										
I			○—○			○—○					
II			○—○	○—○	○		○—○		○—○		

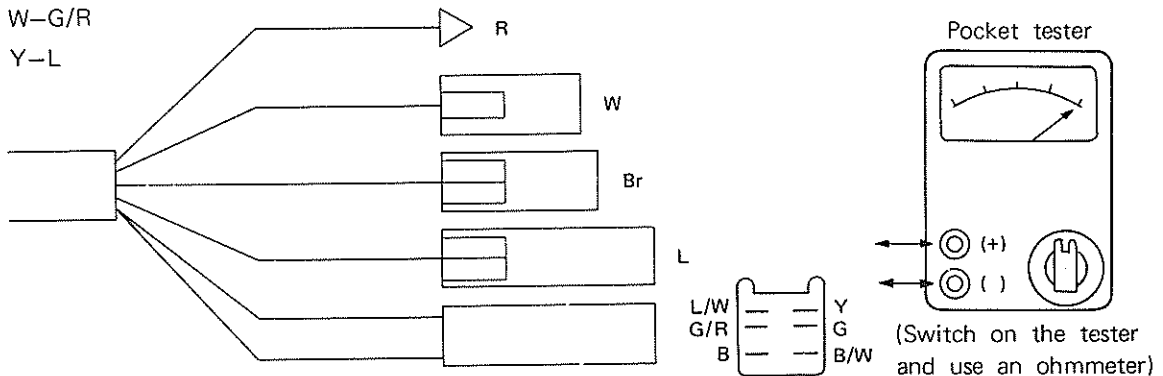

NOTE – Models JT1, JT2M equipped with "Kill Button" only.
Model JT1L equipped with handlebar light switch.

If the readings on the above eight measurements are nearly 0Ω , and no short-circuit is noticed between the terminals, as well as between the lead terminal and the switch body, the main switch is in good condition.

5-10 Spark Plug

The life of a plug and its discoloring vary, according to the habits of the rider. At each periodic inspection, replace burned or fouled plugs with suitable ones determined by the color and condition of the bad plugs. One machine may be ridden only in urban areas at low speeds, whereas another may be ridden for hours at high speeds, so confirm what the present plugs indicate by asking the rider how long and how fast he rides, and recommend a hot, standard, or cold plug accordingly. It is actually economical to install new plugs every 3,000 km (2,000 miles) since it will tend to keep the engine in good condition and prevent excessive fuel consumption.

1. How to "read" spark plug (condition)

- a. Best When the porcelain around the center electrode is a light tan color.
- b. If the electrodes and porcelain are black and some what oily, replace the plug with a hotter-type for low speed riding.
- c. If the porcelain is burned white and/or the electrodes are partially burned away, replace the plug with a colder-type for high speed riding.

2. Inspection

Instruct the rider to:

Inspect and clean the spark plug at least once a month or every 1,000 km. (600 miles). Clean the electrodes of carbon and adjust the electrode gap to 0.5-0.6 mm. (0.023 in.) Be sure to use standard B-7HS plug as replacements to avoid any error in reach or heat range.

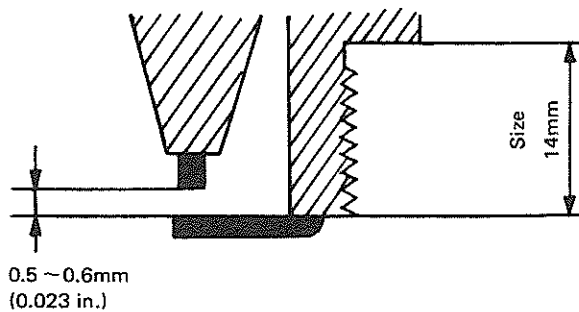

Fig. 5-10-1

5-11 Lighting and Signal Systems –JT2

The lighting and signal systems consist of the horn and stop light (power source-battery) and the head light, tail light and meter lamps. (Power source-flywheel magneto.)

1. Head light

The head light has two 6V, 1.5W bulbs, and a 6V, 1.5W neutral pilot light on its top. A beam directing adjusting screw is fitted on the right side of the light rim so that the horizontal direction of the beam can be adjusted (not vertically).

2. Tail Light and Stop Light

A 6V, 5.8W tail light and a 6V, 17W stop light are mounted. The lens of the tail light is provided with reflectors on its three sides—rear, right and left.

3. Horn

The horn is a 6V, flat type, and has a tone-volume adjusting nut on its back.

After adjustment is made, apply paint or lacquer to the nut for water proofing purposes.

4. Speedometer

A circular type speedometer is mounted on the bracket. For illumination, a 6 V, 3 W bulb is provided.

JT1/JT2M

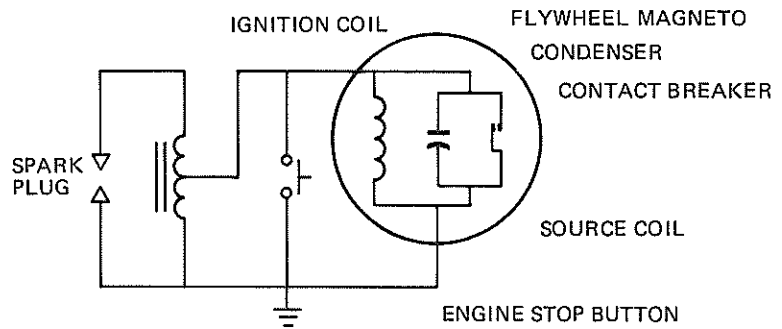

JT1L

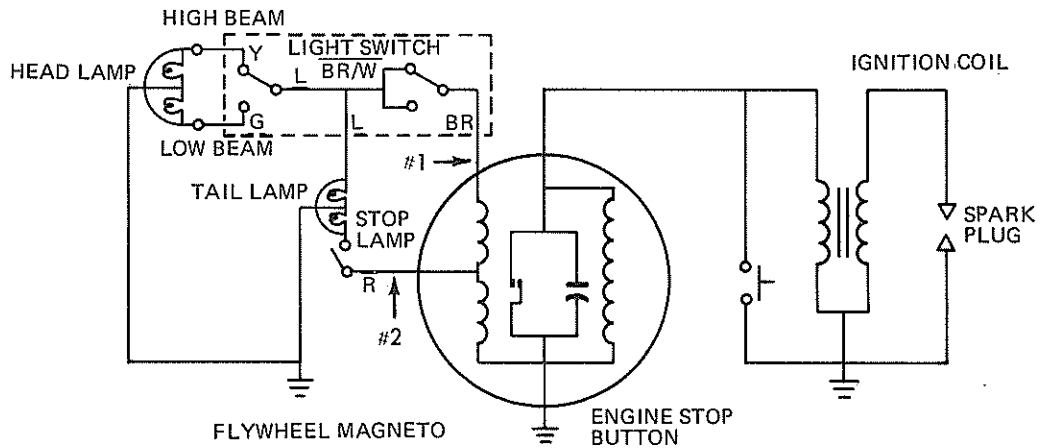

JT2

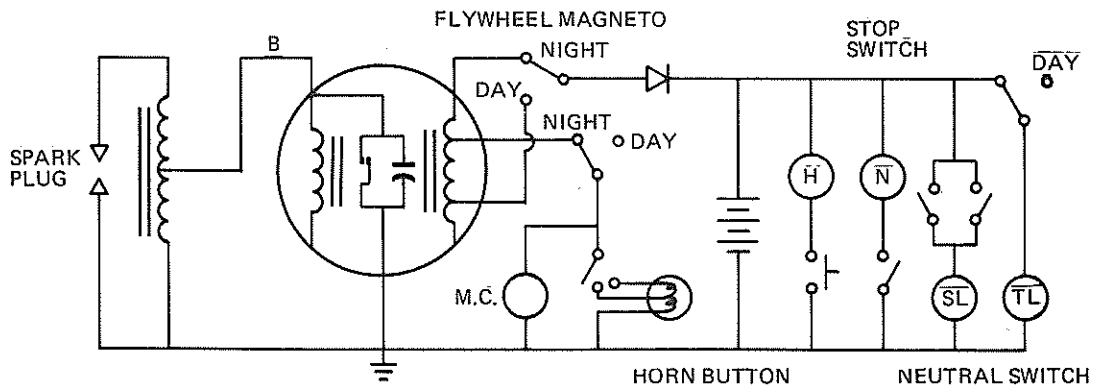

APPENDIX I

PERTINENT PARTS and SERVICE BULLETINS

Note

THE FOLLOWING INFORMATION MUST BE USED AS A GUIDE ONLY TO INDICATE THE DIRECTION TAKEN BY VARIOUS MODIFICATIONS. IT IS INCLUDED ONLY AS AN AID TO SERVICING THE JT SERIES AND, SHOULD A QUESTION ARISE REGARDING A CERTAIN PART, THE MECHANIC SHOULD REFER TO AN UP-TO-DATE MODEL PARTS BOOK, SERVICE OR PARTS NEWS BULLETIN, OR THE MANUFACTURER.

MOTORCYCLE SERVICE NEWS

NUMBER

256

PAGE

I

YAMAHA INTERNATIONAL CORPORATION

MONTEBELLO, CALIFORNIA

DATE 12/2/70

JT1 ROTARY VALVE INSTALLATION (TIMING)

The JT1 rotary valve mounts to the crankshaft in a slightly different manner than previous Yamaha rotary valve models. This requires special valve installation instructions which are given below.

A collar fits over the crankshaft (notch in collar fits over pin in shaft), then the valve fits over the collar. To install the valve in proper relation to the crankshaft, the two indentations in the outer valve surface must line up with the pin in the crankshaft.

Rotary valve timing can also be checked by rotating the piston to top dead center (indicated with dial indicator) and checking that the valve closing edge just lines up with the left edge of the intake port (see drawing).

PIN LOCATION NOTE: The locating pin in the shaft is removable. Although the pin hole is drilled thru the shaft, permitting the pin to protrude from either end of the hole, follow factory installation recommendations. Position the pin to protrude out of the hole end 180° from the crank pin. However, no matter which end the pin extends from, the rotary valve can be correctly timed by lining up the valve closing edge with the intake port.

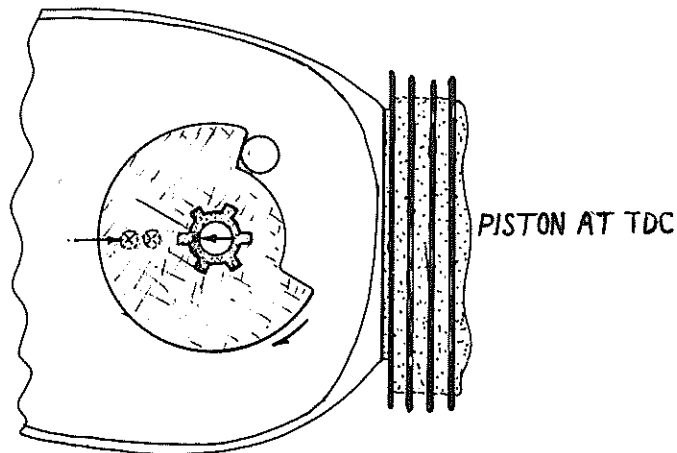

MOTORCYCLE SERVICE NEWS

YAMAHA INTERNATIONAL CORPORATION
BUENA PARK, CALIFORNIA 90620
DATE 12/10/71

NUMBER
258 A
PAGE
1 of 3

1969 thru 1972 Models

AUTOLUBE OUTPUT & COLOR CODE

NOTICE: THIS BULLETIN TAKES THE PLACE
OF SNB #258 - PLEASE DESTROY SNB#258

OUTPUT

The charts on pages two and three, used in conjunction with the test procedure below, can be used to check the pump's actual output against factory nominal specifications.

HOWEVER, pump output variations from nominal specifications very rarely occur. More often than not, the problem is in minimum stroke and/or cable length adjustments... or a mechanical problem such as a loose delivery line fitting, leaky engine seal or gasket, or, occasionally, failure to reinstall the check ball(s) and/or spring(s) in the delivery line.

COLOR CODES

Color codes have been included so that a mechanic can identify a pump installed on a machine or lying loose on a shelf. Note: See Motorcycle Service News Bulletin #198A for color code identification on earlier models.

A. MATERIALS REQUIRED TO CHECK OUTPUT

Purchase a tube graduated in cubic centimeters (purchase from any laboratory equipment & supply house; check local listing in telephone yellow pages) and attach an Autolube delivery line to one end of the tube. Leave the banjo fitting on the other end of the delivery line to provide a universal adaptor for all models.

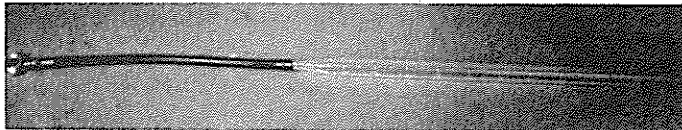

B. PROCEDURE

Whether checking the pump on the machine or bench, the procedure is identical.

1. Disconnect original oil delivery line and attach graduated tube/delivery line unit to outlet hole.
2. Make sure oil tank has a sufficient oil supply to complete this procedure.
3. Determine if output check is to be done at minimum or maximum stroke, and set pump pulley in appropriate position. **IMPORTANT!** When checking at maximum stroke, rotate pump pulley so ramp follows guide pin to maximum stroke position. **DO NOT** push pulley straight in by hand as this will cause the pump stroke to be greater than determined by factory.
4. Rotate plastic pump starter wheel 200 revolutions and compare measured output with specifications listed on page 2.
5. Pump output can be checked within 10-15 minutes. This is much more beneficial than just guessing that pump might be bad, replacing the pump, and running the engine again. It will prevent repeated engine damage (when machine is damaged again after replacing pump) and unnecessary time invested by customer and mechanic.

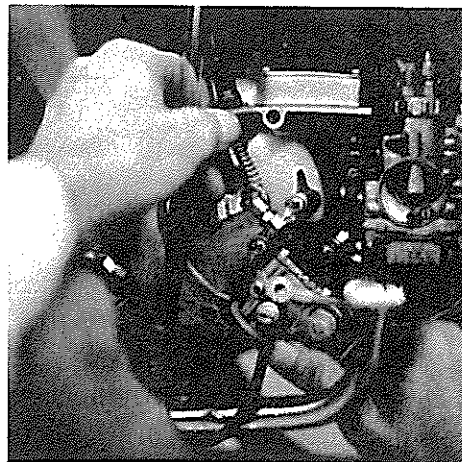

MOTORCYCLE SERVICE NEWS

NUMBER
258A

PAGE

2 of 3

YAMAHA INTERNATIONAL CORPORATION
BUENA PARK, CALIFORNIA 90620

DATE 12/10/71

1969 thru 1972 Models

AUTOLUBE OUTPUT & COLOR CODE (cont'd.)

C. WHAT IF OUTPUT IS CORRECT, AND PROBLEM CONTINUES?

Troubleshooting is a process of considering all possibilities, and eliminating them until the problem(s) is found. Such items and systems to be checked include type of oil, rider habits, timing, piston clearance, and compression (not particularly in this order, nor only those items listed).

1969 thru 1971 Models

	MINIMUM STROKE; cc @ 200 STROKES*	MAXIMUM STROKE; cc @ 200 STROKES*	PUMP COLOR CODE	**REDUCTION RATIOS
JT1	.50 - .63	4.65 - 5.15	White	30/19 x 62/1
G5S	.50 - .63	4.65 - 5.15	Light Blue	28/19 x 55/1
G6S	.50 - .63	4.65 - 5.15	Light Blue	28/19 x 55/1
G6SB	.50 - .63	4.65 - 5.15	Light Blue	28/19 x 55/1
HT1	.50 - .63	4.65 - 5.15	Red	28/19 x 55/1
HT1B	.50 - .63	4.65 - 5.15	Red	28/19 x 55/1
HS1	.50 - .63	4.20 - 4.80	Blue	34/19 x 62/1
HS1B	.50 - .63	4.20 - 4.80	Blue	34/19 x 62/1
YL1 (E)	.50 - .63	4.20 - 4.80	Yellow	34/19 x 62/1
L5T	.50 - .63	4.65 - 5.15	Green	34/19 x 36/1
L5TA	.50 - .63	4.65 - 5.15	Green	34/19 x 36/1
AT1	.95 - 1.19	8.80 - 9.76	Yellow	28/19 x 55/1
AT1B (MX)	.95 - 1.19	8.80 - 9.76	Yellow	28/19 x 55/1
AT1C	.95 - 1.19	8.80 - 9.76	Yellow	28/19 x 55/1
AS2C	.50 - .63	4.17 - 4.80	White	34/19 x 55/1
CT1	.95 - 1.19	8.80 - 9.76	Yellow	28/19 x 55/1
CT1B	.95 - 1.19	8.80 - 9.76	Yellow	28/19 x 55/1
CT1C	.95 - 1.19	8.80 - 9.76	Yellow	28/19 x 55/1
CS1C	.50 - .63	5.15 - 5.70	Dark Blue	20/16 x 55/1
CS3B	.50 - .63	5.15 - 5.70	Dark Blue	20/16 x 55/1
CS3C	.50 - .63	5.15 - 5.70	Dark Blue	20/16 x 55/1
DT1B	.95 - 1.19	8.80 - 9.76	Black	20/21 x 55/1
DT1C	.95 - 1.19	8.80 - 9.76	Black	20/21 x 55/1
DT1E	.95 - 1.19	8.80 - 9.76	Black	20/21 x 55/1
DS6B	.50 - .63	5.15 - 5.70	Pink	20/20 x 40/1
DS6C	.50 - .63	5.15 - 5.70	Pink	20/20 x 40/1
R2/R2C	.50 - .63	5.15 - 5.70	Green	19/23 x 32/1
R3	.50 - .63	5.15 - 5.70	Green	19/23 x 32/1
R5	.50 - .63	5.15 - 5.70	Red	21/23 x 32/1
R5B	.50 - .63	5.15 - 5.70	Red	21/23 x 32/1
RT1 (Old)	1.19 - 1.44	9.10 - 10.05	Green	20/21 x 55/1
RT1 (New)	.95 - 1.19	8.80 - 9.70	Green	20/21 x 55/1
RT1B	.95 - 1.19	8.80 - 9.70	Green	20/21 x 55/1

MOTORCYCLE SERVICE NEWS

NUMBER
258A

PAGE
3 of 3

YAMAHA INTERNATIONAL CORPORATION
BUENA PARK, CALIFORNIA 90620

DATE 12/10/71

1969 thru 1972 Models

AUTOLUBE OUTPUT & COLOR CODE (cont'd.)

1971-1/2 & 1972 Models

	MINIMUM STROKE; cc @ 200 STROKES*	MAXIMUM STROKE; cc @ 200 STROKES*	PUMP COLOR CODE	**REDUCTION RATIOS
U7E	.63 - .73	2.76 - 3.37	Red	68/19 x 56/1
G7S	.50 - .63	4.27 - 4.90	Blue	28/19 x 55/1
LS2	.50 - .63	4.17 - 4.80	Sky Blue	34/19 x 62/1
LT2	.50 - .63	4.65 - 5.15	Blue	28/19 x 40/1
LT2-M	.50 - .63	4.65 - 5.15	Blue	28/19 x 40/1
CS5	.50 - .63	5.15 - 5.65	Brown	20/16 x 55/1
DS7	.50 - .63	5.15 - 5.70	Green	22/21 x 40/1
R5C	.50 - .63	5.15 - 5.70	Red	21/23 x 32/1
JT1L	.75 - .88	3.64 - 4.27	White	30/19 x 62/1
JT2	.75 - .88	3.64 - 4.27	White	30/19 x 62/1
JT2-MX	.75 - .88	3.64 - 4.27	White	30/19 x 62/1
HT1B-MX	.50 - .63	4.65 - 5.15	Red	28/19 x 55/1
AT2	.95 - 1.19	8.80 - 9.76	Yellow	28/19 x 55/1
AT2-M	.95 - 1.19	8.80 - 9.76	Yellow	28/19 x 55/1
CT2	.95 - 1.19	8.80 - 9.76	Yellow	28/19 x 55/1
DT2	.95 - 1.19	8.80 - 9.76	Black	20/21 x 55/1
DT2-MX	.95 - 1.19	8.80 - 9.76	Black	20/21 x 55/1
RT2	.95 - 1.19	8.80 - 9.76	Green	20/21 x 32/1
RT2-MX	.95 - 1.19	8.80 - 9.76	Green	20/21 x 32/1
TD3				
TR3				

*STROKES: 1 pumping stroke occurs for each pump revolution. This is true even for twin cylinder models, as there is only 1 pump stroke for each cylinder per revolution. The quantity is measured only out of one oil delivery line at a time.

** Pump drive gear/primary driven gear x worm wheel/worm shaft.

MOTORCYCLE SERVICE NEWS

NUMBER
261

PAGE
1 of 4

YAMAHA INTERNATIONAL CORPORATION
MONTEBELLO, CALIFORNIA
DATE 1/18/71

JT1 LIGHTING KIT

In order to make the JT1 Mini-Enduro more useable we are now offering a lighting kit for the machine. THE KIT IS NOT STREET LEGAL. It is quite adequate for use in providing off-the-road illumination but has not been approved, at this time, by the various government regulating agencies.

- A. Lighting source coil
 1. Remove magneto cover.
 2. Remove flywheel.
 3. Remove stator plate.
 4. Remove empty source shoe.
 5. Install coil in place of (4.).
 6. Install new grommet (bigger hole for loom, see sketch #3).
 7. Re-install stator.
 8. Route new wires with ignition wire.

- B. Main harness
 1. Remove tank.
 2. Route alongside frame tube (see sketches 1 and 2).

- C. Handle switch
 1. Remove left grip.
 2. Install switch.
 3. Re-install grip.

NOTE: The handle switch is a combined type similar to the DS3 switch. Check the schematic (page 4) carefully in order to wire correctly.

- D. Headlamp stay
 1. Remove triple clamp.
 2. Slide stays over fork tubes.
 3. Tighten 6mm bolts.
 4. Re-install triple clamp.

- E. Headlamp
 1. Install.
 2. Remove lens.
 3. Insert main harness through left hand hole.
 4. Insert handle switch harness through right hand hole.
 5. Hook up wires.

- F. Taillight
 1. Use as template to drill three 6.5mm holes in fender; top hole approximately 3" from fender tip.

MOTORCYCLE SERVICE NEWS

NUMBER
261

PAGE
2 of 4

YAMAHA INTERNATIONAL CORPORATION
MONTEBELLO, CALIFORNIA

DATE 1/18/71

JT1 LIGHTING KIT (Continued)

2. Install light.
 3. Route wiring through fender brace hole and under seat.
- G. Brake light switch
1. Bolt stay to upper rear engine mount, right hand side.
 2. Insert switch rod in brake lever hole.
 3. Adjust as necessary.
- H. Connections
1. Main harness, taillight leads, and source wires terminate under seat.
 2. Use nylon clip to secure to righthand frame tube next to (and over) oil tank (do not allow wires to touch muffler).
 3. Caution: See sketches as otherwise shorts may occur.
 4. Hook up according to schematic, page 4.
 5. Re-install seat, tank, etc.
 6. Check output per voltage curve, Page 3.

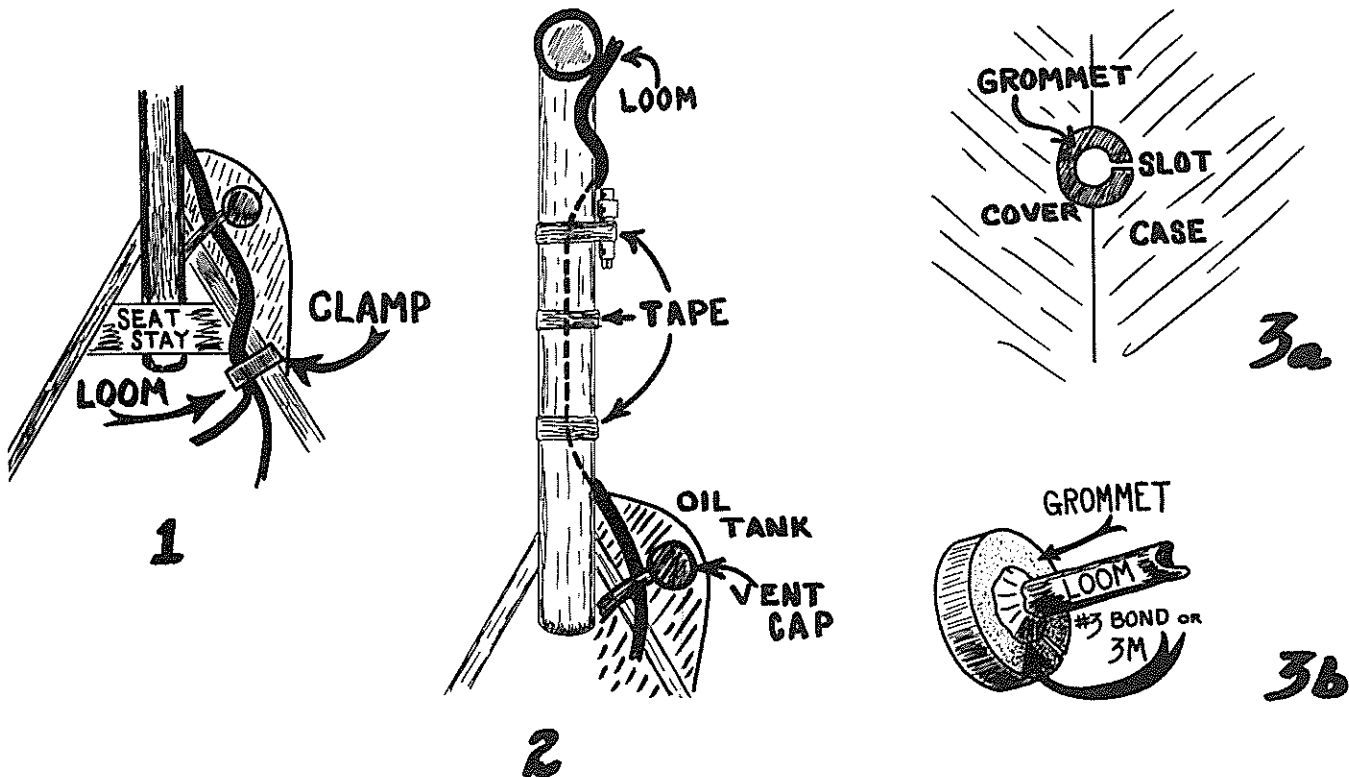

MOTORCYCLE SERVICE NEWS

NUMBER
261

PAGE
3 of 4

YAMAHA INTERNATIONAL CORPORATION
MONTEBELLO, CALIFORNIA

DATE 1/18/71

JT1 LIGHTING KIT (Continued)

Motorcycle Parts News Bulletin #304 gives complete ordering information on the above kit. However, for your convenience, we are adding a parts list only.

<u>PART NUMBER</u>	<u>DESCRIPTION</u>	<u>QUANTITY</u>
ACC-01100-04-00	JT1 Lighting Kit (comp)	1
288-84110-60-00	•HEADLAMP UNIT ASSY	1
241-84330-00-74	•BODY	1
473-84313-00-00	•WIRE, Earth	1
195-84325-00-00	•SCREW	1
290-84118-00-00	•STAY, Headlamp	1
290-84119-00-00	•STAY, Headlamp	1
91201-06015-00	•BOLT	2
92901-06200-00	•WASHER	2
97204-08020-00	•BOLT	2
92903-08200-00	•WASHER	2
92901-08100-00	•WASHER	2
98801-08100-00	•NUT	2
288-84510-60-00	•TAILLAMP UNIT ASSY	1
288-34551-09-00	•BRACKET	1
152-84518-00-00	•GROMMET	2
91201-06012-00	•BOLT	3
98801-06100-00	•NUT	3
92201-06100-00	•WASHER	3
290-82530-00-00	•STOP SWITCH	1
290-82539-99-00	•STAY, Switch	1
288-83973-00-00	•SWITCH, Handle	1
214-83974-00-00	•HOLDER, Switch	1
98503-05018-00	•SCREW	1
288-81313-10-00	•COIL LITE	1
288-82590-20-00	•WIRE, Harness	1
803-82591-00-00	•CLAMP, Wiring	1

VOLTAGE CHECK: After installation, start the machine and check the lighting coil output. (Voltage will be + 10%)

		3,000 rpm	8,000 rpm
Stop Lamp only	#2	8.9V	8.5V
Head lamp/tail lamp	#1	4.5V	8.0V
ALL lamps burning	#1	4.0V	7.5V
	#2	1.7V	3.5V

NOTE: See schematic on next page for measurement points #1 and #2.

MOTORCYCLE PARTS NEWS

YAMAHA INTERNATIONAL CORPORATION
BUENA PARK, CALIFORNIA 90620

DATE 7/10/71

NUMBER
310

PAGE

1 of 1

JT1 STEERING BEARING RACES/CARBURETOR CAP

#1: Steering bearing races (Fig. No. 18-1)

Both inner races (referred to as RACE #2 in Parts Book) have been modified to provide greater strength. Originally, top and bottom inner races were identical, but are now two differently sized races. There is no change, however, in bearing balls.

These parts have been included in standard models after engine #26308, and should be used as replacement parts on all JT1's.

NOTE: The front fork guide (Fig. No. 17-27, JT1 Parts Book) cannot be used with these newer bearing races because the inner race holes are now too small to let the guide pass through. This part is not absolutely needed as its only purpose is to help align the underbracket during installation.

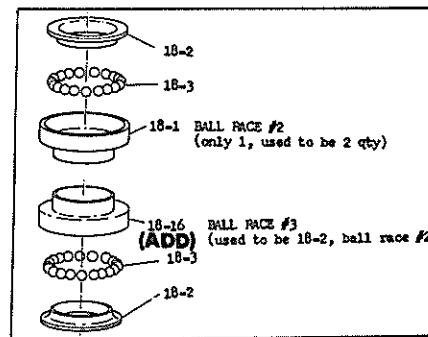

PARTS BOOK CORRECTION: Original JT1 Parts Book picture on page 49 shows top and bottom bearing assemblies upside down. Rearrange as in picture above.

Fig.No.	Description	Old Part Number	New Part Number	Qty.	Retail/Disc.	Remarks
18-1	BALL RACE #2	282-23412-00-00	282-23412-01-00	1	\$.94/ A	Qty used to be 2.
18-16 (add)	BALL RACE #3	282-23412-00-00	288-23413-00-00	1	\$.94/ A	E/N26309

#2: Carburetor cap (Fig. No. 2-20)

The carburetor cap design has been changed to permit an elastic steel band to be installed around its outer edge. This will help to hold the cap more securely in place.

These parts are standard equipment on JT1's after engine number 025908.

New and old caps are available, but the new cap can be interchanged on earlier machines without modification.

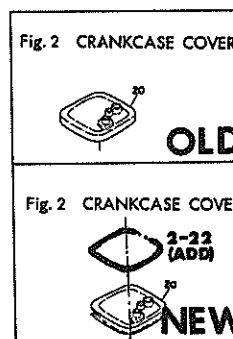

Fig.No.	Description	Old Part Number	New Part Number	Qty.	Retail/Disc.	Remarks
2-20	CAP, carbur- etor	288-14481-00-00	288-14481-01-00	1	\$.62/ A	E/N25909 ~
2-22 (add)	BAND, spring	-----	288-14455-00-00	1	\$.26/ A	E/N25909 ~

PLEASE BRING YOUR PARTS BOOKS AND PRICE LIST UP TO DATE

#####

MOTORCYCLE PARTS NEWS

YAMAHA INTERNATIONAL CORPORATION
BUENA PARK, CALIFORNIA 90620

DATE 8/22/72

NUMBER

347

PAGE

1 of 1

JT2/JT2-MX

AIR CLEANER COVER JOINT

The metal retaining cover for the rubber air cleaner joint is now available from the Parts Department. Please update your JT2/JT2-MX Parts List to include this part.

PARTS ORDERING

<u>Ref. No.</u>	<u>Part Number</u>	<u>Description</u>	<u>Qty.</u>	<u>Price</u>
9 - 15	288-14417-00-00	COVER, Joint	1	

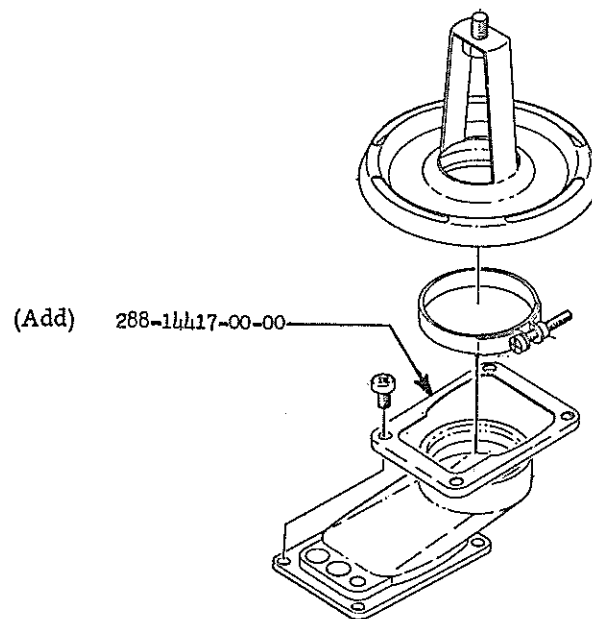

#

APPENDIX II

PARTS ILLUSTRATIONS

FIG. I CRANKCASE AND CYLINDER

1. Left crank case
2. Right crank case
3. Dowel pin
4. Pan head screw
5. Pan head screw
6. Pan head screw
7. Pan head screw
8. Pan head screw
9. Pan head screw
10. Cylinder holding bolt
11. Cylinder gasket
12. Cylinder
13. Cylinder head gasket
14. Cylinder head
15. Cylinder holding nut
16. Plain washer
17. Drain plug
18. Drain plug gasket
19. Breather
20. Rubber ring
21. Valve cover
22. O-ring
23. O-ring
24. Dowel pin
25. Pan head screw
26. Blind plug
27. Gasket

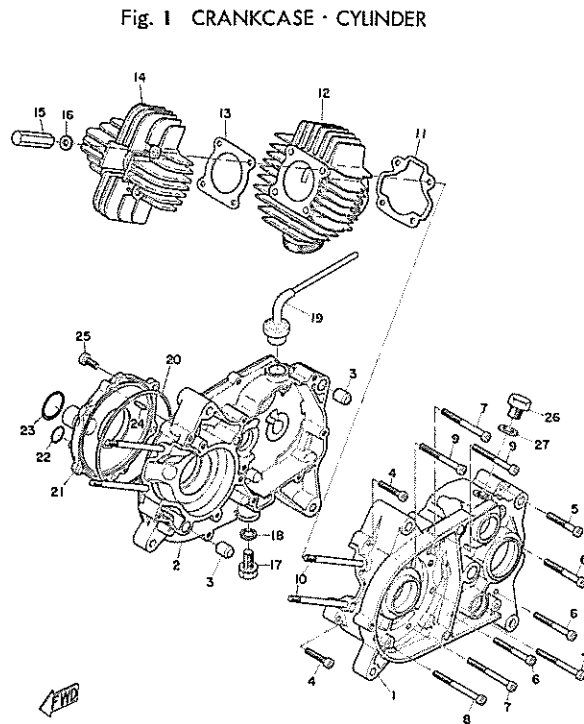

Fig. II CRANK · PISTON

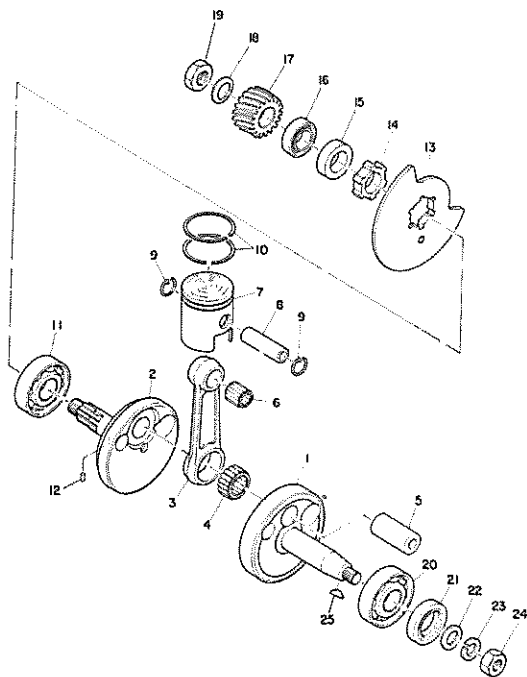

FIG. II CRANK AND PISTON

1. Left crank
2. Right crank
3. Connecting rod
4. Con-rod big end bearing
5. Crank pin
6. Con-rod small end bearing
7. Piston
8. Piston pin
9. Piston pin clip
10. Piston ring set
11. Bearing
12. Dowel pin
13. Valve
14. Valve collar
15. Distance collar
16. Oil seal
17. Primary drive gear
18. Belleville spring
19. Clutch boss nut
20. Bearing
21. Oil seal
22. Washer
23. Spring washer
24. Nut
25. Woodruff key

Fig. III MUFFLER

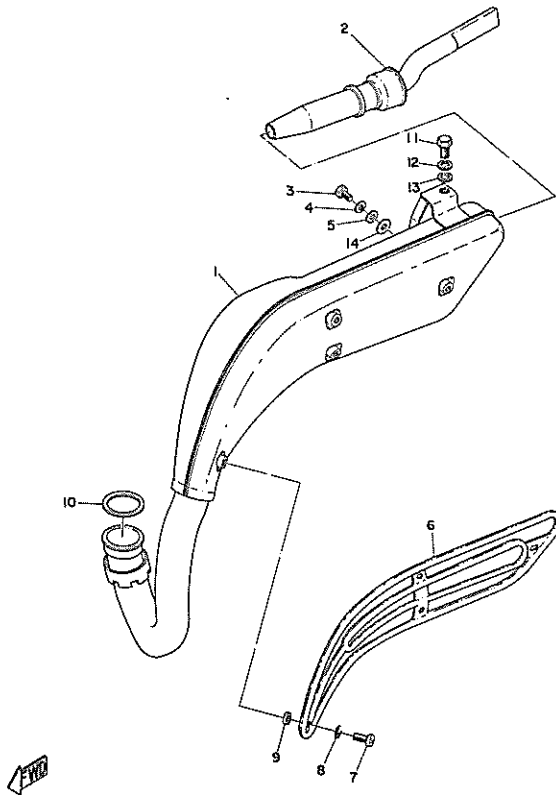

FIG. III - JT1 - MUFFLER

1. Exhaust pipe assembly
2. Outlet pipe
3. Bolt
4. Spring Washer
5. Chain case washer
6. Muffler protector
7. Bind Screw
8. Protector washer
9. Protector washer
10. Exhaust gasket
11. Bolt
12. Spring washer
13. Plain washer
14. Gasket

FIG. IV - JT2 - MUFFLER

1. Exhaust pipe assembly
2. Outlet pipe
3. Bolt
4. Spring washer
5. Chain case washer
6. Muffler protector
7. Bind screw
8. Protector washer
9. Protector washer
10. Exhaust gasket
11. Bolt
12. Spring washer
13. Plain washer
14. Gasket

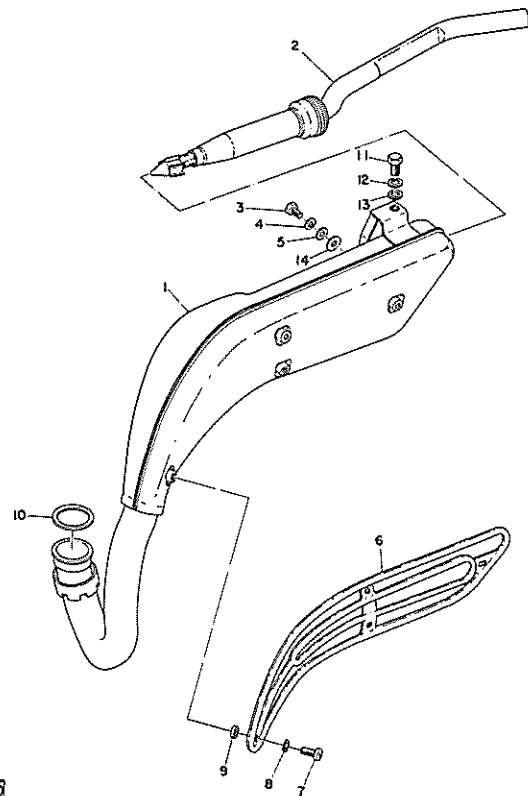

Fig. IV EXHAUST

APPENDIX II

FIG. V – JT1/JT1L – FLYWHEEL MAGNETO

JT1

1. Rotor assembly
2. Source coil
3. Pan head screw
4. Spring washer
5. Timing plate
6. Contact breaker assembly
7. Pan head screw
8. Spring washer
9. Plain washer
10. Condenser
11. Pan head screw
12. Spring washer
13. Lubricator
14. Lead clamp
15. Pan head screw
16. Spring washer
17. Flat head screw

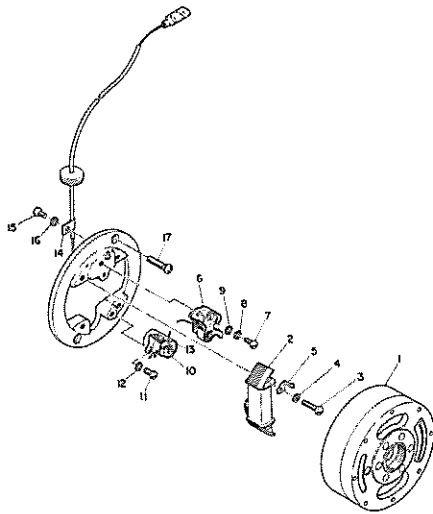

JT1L

- | | |
|-----------------------------|---------------------|
| 1. Rotor assembly | 10. Plain washer |
| 2. Source coil | 11. Condenser |
| 3. Lighting coil | 12. Pan head screw |
| 4. Pan head screw | 13. Spring washer |
| 5. Spring washer | 14. Lubricator |
| 6. Timing plate | 15. Lead clamp |
| 7. Contact breaker assembly | 16. Pan head screw |
| 8. Pan head screw | 17. Spring washer |
| 9. Spring washer | 18. Flat head screw |

Fig. V FLYWHEEL MAGNETO

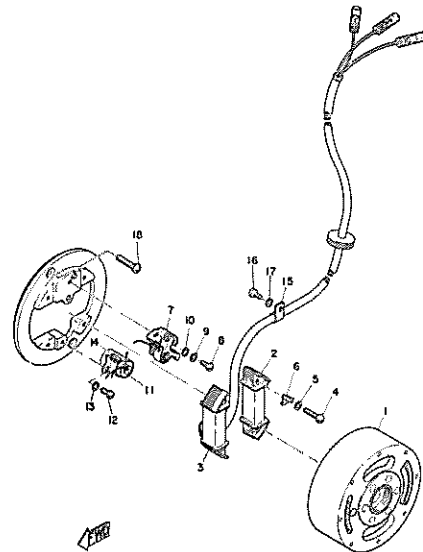
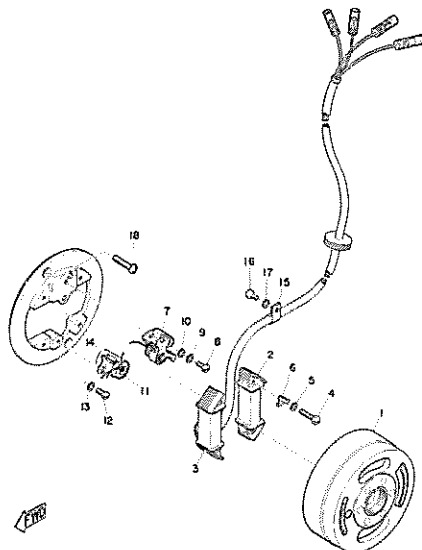

FIG. VI – JT2 – FLYWHEEL MAGNETO

Fig. VI FLYWHEEL MAGNETO



JT2

1. Rotor assembly
2. Source coil
3. Lighting coil
4. Pan head screw
5. Spring washer
6. Timing plate
7. Contact breaker assembly
8. Pan head screw
9. Spring washer
10. Plain washer
11. Condenser
12. Pan head screw
13. Spring washer
14. Lubricator
15. Lead clamp
16. Pan head screw
17. Spring washer
18. Flathead screw

FIG. VII – ELECTRICAL COMPONENTS

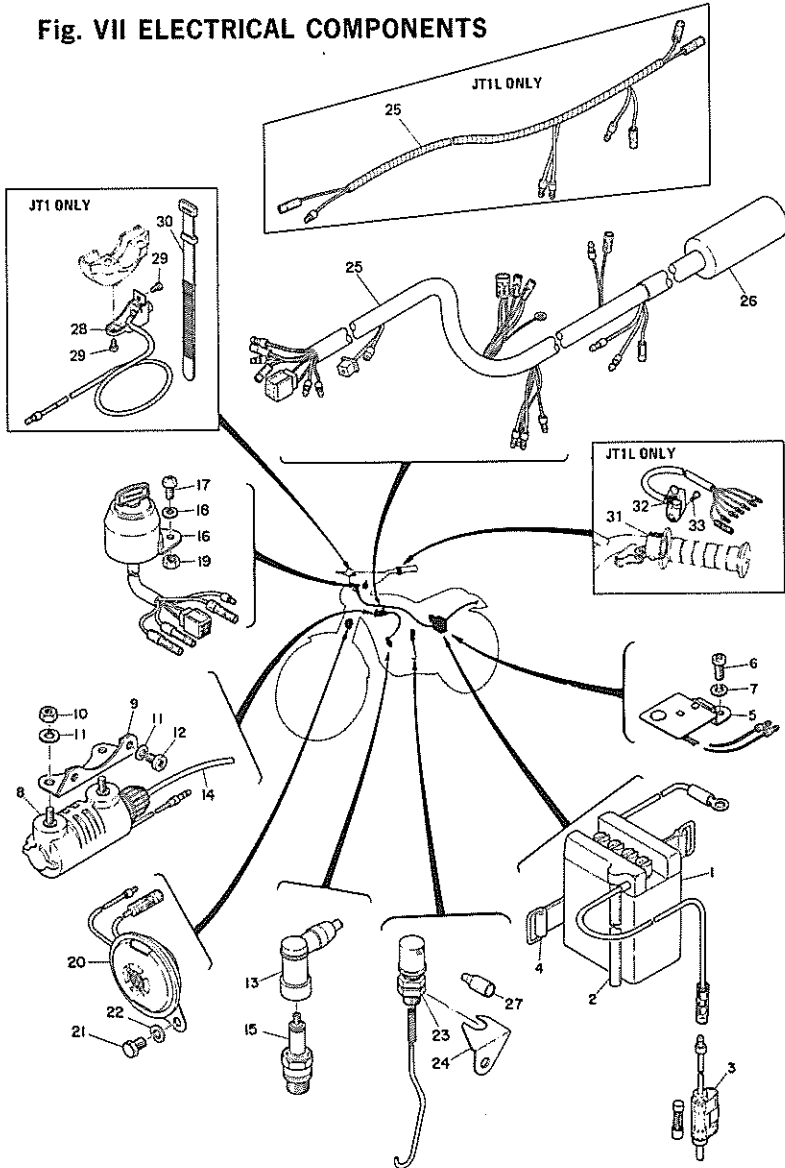

	JT1	JT1L	JT2
1. Battery assembly			1
2. Breather pipe			1
3. Fuse holder assembly			1
4. Battery band			1
5. Rectifier assembly			1
6. Pan head screw			1
7. Spring washer			1
8. Ignition coil assembly	1	1	1
9. Ignition coil bracket	1	1	1
10. Nut	1	1	1
11. Spring washer	1	1	1
12. Pan head screw	1	1	1
13. Plug cap assembly	1	1	1
14. High tension cord	1	1	1
15. Spark plug	1	1	1
16. Main switch assembly			1
17. Pan head screw			1
18. Spring washer			1
19. Nut			1
20. Horn			1
21. Bolt			1
22. Spring washer			1
23. Stop switch assembly		1	1
24. Stop switch stay		1	1
25. Wire harness assembly		1	1
26. Connector cover			1
27. Connector cover		1	1
28. Handle switch	1		
29. Pan head screw	1		
30. Switch cord band	1		
31. Handle switch holder		1	
32. Handle switch		1	
33. Pan head screw		1	

LUBRICATION INTERVALS

Page	Item	Remarks	Type	Period					
				Initial (miles)			Thereafter every (miles)		
				250	500	1,000	500	1,000	
7	Autolube	P R E O P C H K	See Service Notes	#1	See Service Notes				
-	Trans. Oil		Warm Engine Before Draining	#2	0	CHK	0	CHK	0
-	Drive Chain		Lube/Adjust as required	#3	See Service Notes				
-	Drive Chain		Remove/Clean/Lube/Adjust	#3	0		0		
44	Air Filter		Foam Type	#9	See Service Notes				
-	Throttle Grip & Housing		Light Application	#5	0				0
-	Rear Arm Pivot Shaft		Lube Periodically	#6		0			0
-	Brake Pedal Shaft		Light Application	#5		0			0
-	Change Pedal Shaft		Light Application	#5		0			0
55	Front Forks	Drain Completely-Ck Specs	#3	CHK	0			0	
-	Steering Ball Races	Inspect Thoroughly/Med. Pack	#7		0			0	
-	Point Cam Lubr. Wick	Very Light Application	#8		0			0	
-	Wheel Bearings	Do not Over-Pack	#7		0			0	

- #1. Check tank level before each ride. Top off when oil level is at sight glass or before any prolonged use. Use the following lubricant (in order of preference):
Yamalube, or two-stroke oil labeled "BIA certified for service TC-W"
- #2. At ambient temperatures of 45-90°F, use YAMALUBE 4-stroke. Do not use "additives" in oil.
- #3. Use 10W/30 "SE" motor oil. (If desired, specialty type lubricants of quality manufacture may be used.)
"Drive Chain"—Lube every 150-200 miles. If severe usage, every 50-100 miles or daily.
- #4. Use graphic base type (specialty types available—use name-brand, quality manufacturer).
- #5. Light duty: smooth, lightweight, "White" grease. Heavy duty: standard 90wt. lube grease (do not use lube grease on throttle/housing).
- #6. Use standard 90wt. lube grease—smooth, not coarse.
- #7. Medium-weight wheel bearing grease of quality manufacturer—preferably waterproof.
- #8. Lightweight machine oil.
- #9. Air filters—foam element air filters must be damp with oil at all times to function properly. Clean and lube monthly or per mileage. If hard usage, clean and lube daily. Do not over-oil. Use SAE 10W/30 "SE".

PERIODIC MAINTENANCE INTERVALS

Page	Item	Remarks	Initial (miles)		Thereafter every (miles)	
			250	500	500	1,000
48-49	Brake System (Complete)	A L S O P R E O P C H K	Chk/Adj. as required-Repair as required		0	0
22-26	Clutch		Check/Adjust as required		0	0
69-70	Spark Plug		Inspect/Clean or replace as required		0	0
46-54	Wheels and Tires		Pressure/Spoke Tension/Runout		0	0
-	Fittings and Fasteners		Tighten before each trip		0	0
-	Grip wire		Cable Oper/Adj. (incl. Autolube)		0	0
54	Drive Chain		Tension/Alignment		0	0
	Transmission Oil Level Check		Includes Trans./Autolube Tank (See Note #1)		0	0
44	Air Filter		Foam Type (See Service Notes #2 & #4)		0	0
-	Fuel Petcock	Clean/Flush Tank as required		0	0	
63	Ignition Timing	Adjust/Clean/Replace points as required		0	0	
43-44	Carburetor Adjustment	Check Operation/Synch./Fittings		0	0	
42-43	Carburetor Overhaul	Clean/Repair as required/Refit/Adjust		0	0	
16	Cylinder Compression	Preventive Maintenance Check		0	0	
-	Decarbonize Engine	Includes Exhaust System		0	0	

SERVICE NOTES:

- #1. Check Autolube tank level before each ride. Top off when oil level shows at the sight glass or before any prolonged use. See "Lubrication Intervals" for type of oil to use.
- #2. Foam elements air filters must be damp with oil at all times to function properly. Remove, clean, and oil filter at least once per month or every 250 ~ 500 miles; whichever occurs first. (If extremely hard usage, such as dirt riding, clean and lube daily.) See "Lubrication Intervals" for additional details.
- #3. Pre-operational checks should be made each time the machine is used. Such an inspection can be thoroughly accomplished in a very short time, and the added safety it assures the rider is more than worth the minimal time involved.
- #4. For additional information regarding drive chain, transmission oil level, wet-type air filter, see "Lubrication Intervals".

PRE-OPERATION CHECK CHART

ITEM	ROUTINE	PAGE
BRAKES	Check operation/adjustment	
CLUTCH	Check operation/lever adjustment	
AUTOLUBE TANK	Check oil level/top-off as required	
TRANSMISSION	Top-off as required	
DRIVE CHAIN	Check alignment/adjustment/lubrication	
BATTERY (JT2)	Check electrolyte level weekly/top-off monthly	
SPARK PLUG(S)	After break-in - check color/cond'n weekly/1,000 mi.	
AUTOLUBE PUMP	Check for proper cable operation	
AIR FILTER	Foam type - must be clean and damp w/oil always	
WHEELS & TIRES	Check pressure/runout/spoke tightness/axle nuts	
FITTINGS/FASTENERS	Check all - tighten as necessary	
LIGHTS/SIGNALS (JT1L/JT2)	Check headlight/tail - stop lights	

Pre-operation checks should be made each time the machine is used. Such an inspection can be thoroughly accomplished in a very short time; and the added safety it assures is more than worth the time involved.

Torque Specifications

The list below covers those stud/bolt sizes with standard I.S.O. pitch threads. Torque specifications for components with thread pitches other than standard are given within the applicable chapter.

Torque specifications call for dry, clean threads. Components such as the cylinder or cylinder head should be at room temperature prior to torquing. A cylinder head or any other item with several fasteners should be torqued down in a cross-hatch pattern in successive stages until torque specification is reached. The method is similar to installing an automobile wheel and will avoid warping the component.

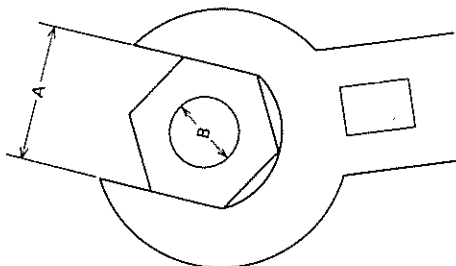

A (NUT)	B (BOLT)	TORQUE SPECIFICATION		
		Kg-m	Ft-lbs	In-lbs
10mm	6mm	1.0	7.2	85
13mm	8mm	2.0	15	175
14mm	8mm	2.0	15	175
17mm	10mm	3.5~4.0	25~29	300~350
19mm	12mm	4.0~4.5	29~33	350~400
22mm	14mm	4.5~5.0	33~36	400~440
26mm	17mm	5.8~7.0	42~50	500~600
27mm	18mm	5.8~7.0	42~50	500~600
30mm	20mm	7.0~8.3	50~60	600~700
SPARK PLUG		2.7~2.9	19~21	230~250

APPENDIX V

CLEANING AND STORAGE

A. Cleaning

Frequent thorough cleaning of your motorcycle will not only enhance its appearance but will improve general performance and extend the useful life of many components.

1. Before cleaning the machine:
 - a. Block off end of exhaust pipe to prevent water entry; a plastic bag and strong rubber band may be used.
 - b. Remove air cleaner or protect it from water with plastic covering.
 - c. Make sure spark plug(s), gas cap, oil tank cap, transmission oil filler cap and battery caps are properly installed.
2. If engine case is excessively greasy, apply degreaser with a paint brush. Do not apply degreaser to chain, sprockets, or wheel axles.
3. Rinse dirt and degreaser off with garden hose, using only enough hose pressure to do the job. Excessive hose pressure may cause water seepage and contamination of wheel bearings, front forks, brake drums, and transmission seals. Many expensive repair bills have resulted from improper high-pressure detergent applications such as those available in coin-operated car washes.

4. Once the majority of the dirt has been hosed off, wash all surfaces with warm water and mild, detergent-type soap. An old tooth brush or bottle brush is handy to reach those hard-to-get-to places.
5. Rinse machine off immediately with clean water and dry all surfaces with a chamois, clean towel, or soft absorbent cloth.
6. Immediately after washing, remove excess moisture from chain and lubricate to prevent rust.
7. Chrome-plated parts such as handlebars, rims, spokes, forks, etc., may be further cleaned with automotive chrome cleaner.
8. Clean the seat with a vinyl upholstery cleaner to keep the cover pliable and glossy.
9. Automotive-type wax may be applied to all painted and chrome-plated surfaces. Avoid combination cleaner-waxes. Many contain abrasives which may mar paint or protective finish on fuel and oil tanks.
10. After finishing, start the engine immediately and allow to idle for several minutes.

B. Storage

Long term storage (30 days or more) of your motorcycle will require some preventive procedures to insure against deterioration. After cleaning machine thoroughly, prepare for storage as follows:

1. Drain fuel tank, fuel lines, and carburetor float bowl(s).
2. Remove empty fuel tank, pour a cup of 10W to 30W oil in tank, shake tank to coat inner surfaces thoroughly and drain off excess oil. Re-install tank.
3. Remove spark plug(s), pour about one tablespoon of 10W to 30W oil in spark plug hole(s) and re-install spark plugs. Kick engine over several times (with ignition off) to coat cylinder walls with oil.
4. Remove drive chain. Clean thoroughly with solvent and lubricate with graphite-base chain lubricant. Re-install chain or store in a plastic bag (tie to frame for safe-keeping).
5. Lubricate all control cables.
6. Remove battery and charge. Store in a dry place and re-charge once a month. Do not store battery in an excessively warm or cold place (less than 32°F or more than 90°F).

7. Block up frame to raise both wheels off ground. (Main stands can be used on machines so equipped.)
8. Deflate tires to 15psi.
9. Tie a plastic bag over exhaust pipe outlet(s) to prevent moisture entering.
10. If storing in humid or salt-air atmosphere, coat all exposed metal surfaces with a light film of oil. Do not apply oil to rubber parts or seat cover.

MILLIMETERS TO INCHES

	0	0.1	0.2	0.3	0.4	0.5	0.6	0.7	0.8	0.9
0		0.0039	0.0079	0.0118	0.0157	0.0197	0.0236	0.0276	0.0315	0.0354
1	0.0394	0.0433	0.0472	0.0512	0.0551	0.0591	0.0630	0.0669	0.0709	0.0748
2	0.0787	0.0827	0.0866	0.0906	0.0945	0.0984	0.1024	0.1063	0.1102	0.1142
3	0.1181	0.1200	0.1260	0.1299	0.1339	0.1378	0.1417	0.1457	0.1496	0.1535
4	0.1575	0.1614	0.1654	0.1693	0.1732	0.1772	0.1811	0.1850	0.1890	0.1929
5	0.1969	0.2000	0.2047	0.2087	0.2126	0.2165	0.2205	0.2244	0.2283	0.2323
6	0.2362	0.2402	0.2441	0.2480	0.2520	0.2559	0.2598	0.2638	0.2677	0.2717
7	0.2756	0.2795	0.2835	0.2874	0.2913	0.2953	0.2992	0.3031	0.3071	0.3110
8	0.3150	0.3189	0.3228	0.3268	0.3307	0.3346	0.3386	0.3425	0.3465	0.3504
9	0.3542	0.3583	0.4016	0.3661	0.3701	0.3740	0.3780	0.3819	0.3858	0.3898
10	0.3937	0.3976	0.4016	0.4055	0.4094	0.4134	0.4173	0.4213	0.4252	0.4291

0.01mm=0.004 0.03mm=0.0012 0.05mm=0.0020 0.07mm=0.0028 0.09mm=0.0035
 0.02mm=0.008 0.04mm=0.0016 0.06mm=0.0024 0.08mm=0.0031 0.10mm=0.0039

INCHES TO MILLIMETERS

	0	0.01	0.02	0.03	0.04	0.05	0.06	0.07	0.08	0.09
0		0.254	0.508	0.762	1.016	1.270	1.524	1.778	2.032	2.286
0.1	2.540	2.794	3.048	3.302	3.556	3.810	4.064	4.318	4.572	4.826
0.2	5.080	5.334	5.588	5.842	6.096	6.350	6.604	6.858	7.112	7.366
0.3	7.620	7.874	8.128	8.382	8.636	8.890	9.144	9.398	9.652	9.906
0.4	10.160	10.414	10.668	10.922	11.176	11.430	11.684	11.938	12.192	12.446
0.5	12.700	12.954	13.208	13.462	13.716	13.970	14.224	14.478	14.732	14.986
0.6	15.240	15.494	15.748	16.002	16.256	16.510	16.764	17.018	17.272	17.526
0.7	17.780	18.034	18.288	18.542	18.796	19.050	19.304	19.558	19.812	20.066
0.8	20.320	20.574	20.828	21.082	21.336	21.590	21.844	22.098	22.352	22.606
0.9	22.860	23.114	23.368	23.622	23.876	24.130	24.384	24.638	24.892	25.146
1.0	25.400	25.654	25.908	26.162	26.416	26.670	26.924	27.178	27.432	27.686

0.001"=0.0254mm 0.003"=0.0762mm 0.005"=0.1270mm 0.007"=0.1778mm 0.009"=0.2286mm
 0.002"=0.0508mm 0.004"=0.1016mm 0.006"=0.1524mm 0.008"=0.2032mm 0.010"=0.254mm

APPENDIX VI

9-2. Conversion Tables

Metric to Inch System				Inch to Metric System			
	Known	Multiplier (Rounded Off)	Result		Known	Multiplier (Rounded Off)	Result
Torque	kg-m	7.235	ft-lbs	Torque	ft-lbs	0.13826	kg-m
	kg-m	86.82	in.-lbs		in.-lbs	0.01152	kg-m
	kg-cm	.0724	ft-lbs		ft-lbs	13.825	kg-m
	kg-cm	.8682	in.-lbs		in.-lbs	1.1518	kg-m
Weight	kg	2,205	lb	Weight	lb	0.4536	kg
	g	.03527	oz		oz	28.35	g
Flow/ Distance	Km/l	2.352	mpg	Flow/ Distance	mpg	0.4252	Km/l
	Km/hr	0.6214	mph		mph	1.609	Km/hr
	Km	0.6214	mi		mi	1.609	Km
	m	3.281	ft		ft	0.3048	m
	m	1.094	yd		yd	0.9144	m
	cm	0.3937	in.		in.	2.54	cm
	mm	0.03937	in.		in.	25.4	mm
Volume/ Capacity	cc (cm ³)	0.03381	oz (U.S. liq.)	Volume/ Capacity	oz (U.S. liq.)	29.57	cc (cm ³)
	cc (cm ³)	0.06102	cu in.		cu in.	16.387	cc (cm ³)
	l (Liter)	2.1134	pt (U.S. liq.)		pt (U.S. liq.)	0.4732	l (Liter)
	l (Liter)	1.057	qt (U.S. liq.)		qt (U.S. liq.)	0.9463	l (Liter)
	l (Liter)	0.2642	gal (U.S. liq.)		gal (U.S. liq.)	3.7853	l (Liter)
Misc.	kg/mm	56.007	lb/in.	Misc.	lb/in.	0.017855	kg/mm
	kg/cm ²	14.2234	psi (lb/in. ²)		psi (lb/in. ²)	0.07031	kg/cm ²
	Centigrade (°C)	9/5(°C+32)	Fahrenheit (°F)		Fahrenheit (°F)	5/9(°F-32)	Centigrade(°C)

Definition of Terms:

- m-kg = Meter Kilograms: Usually torque.
- g = Gram(s).
- kg = Kilogram(s): 1,000 grams.
- km = Kilometer(s).
- l = Liter(s).
- km/l = Kilometer(s) Per Liter: Mileage.
- cc = Cubic Centimeter(s) (cm³): Volume or Capacity.
- kg/mm = Kilogram(s) Per Millimeter: Usually Spring Compression Rate.
- kg/cm² = Kilogram(s) Per Square Centimeter: Pressure.

WIRING DIAGRAM (JT2)

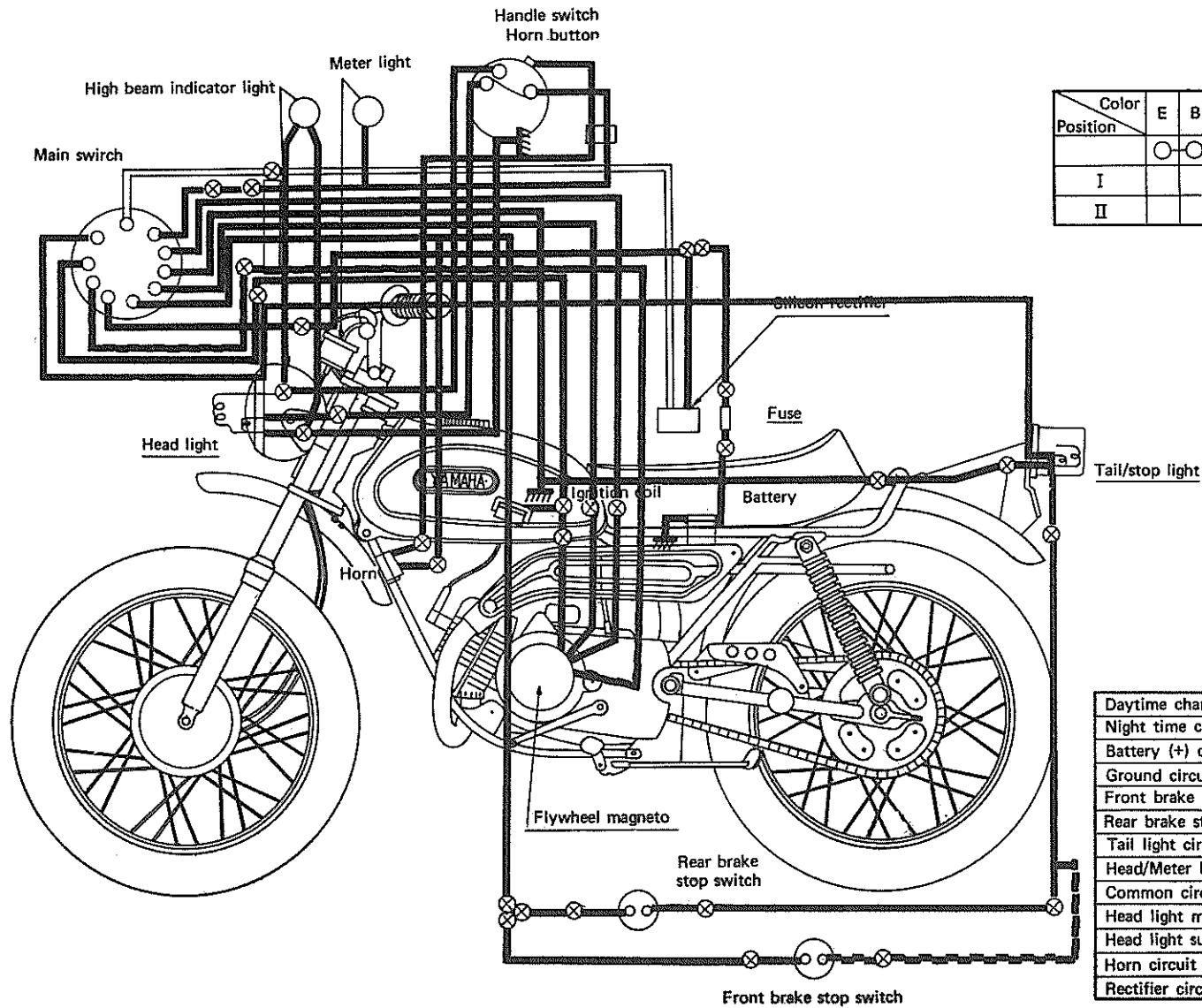

Color Position	E	B	R	Br	L	G	W	GR	LW	Y
	○	○								
I			○	○		○	○			
II			○	○	○		○	○	○	○

Daytime charging circuit	Green	○
Night time charging circuit	Green/Red	○
Battery (+) circuit	Red	○
Ground circuit	Black	○
Front brake stop light circuit	Green/Yellow	○
Rear brake stop light circuit	Yellow	○
Tail light circuit	Blue	○
Head/Meter light circuit	Blue (L.W)	○
Common circuit	Brown	○
Head light main circuit	Yellow	○
Head light sub circuit	Green	○
Horn circuit	Pink	○
Rectifier circuit	White	○

