



YAMAHA

PARTS LIST

YAMAHA MINI ENDURO

MODEL JT1

YAMAHA MOTOR CO., LTD.

YAMAHA

PARTS LIST

MINI ENDURO JT1



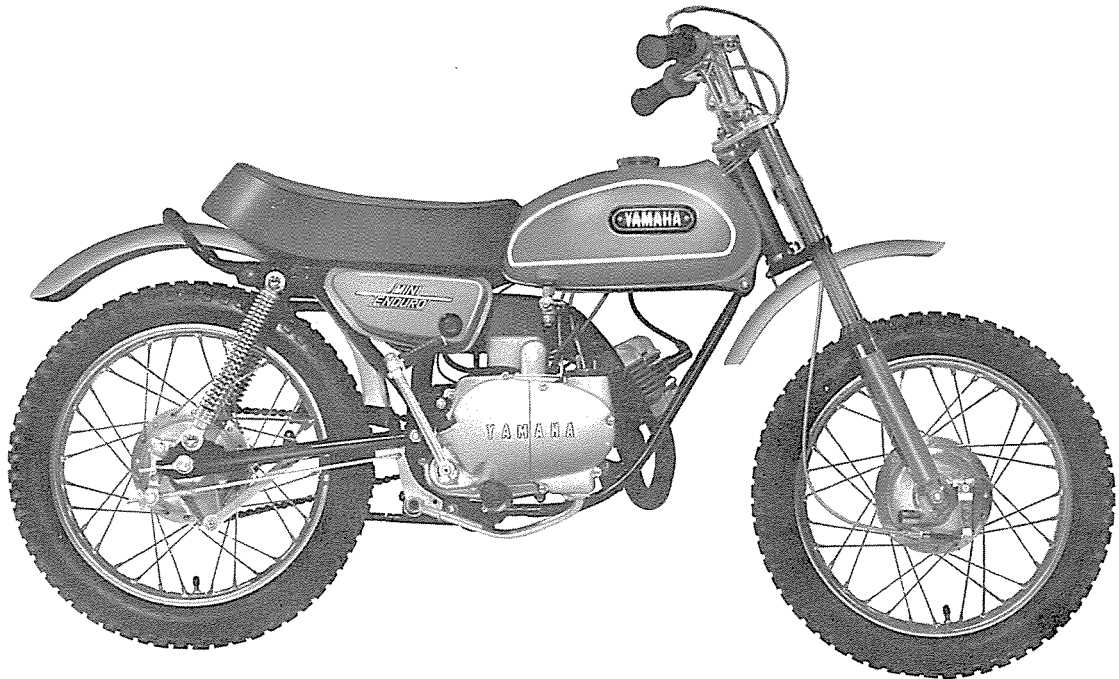



FOREWORD

This Parts List related to the parts in use for the YAMAHA JT1.

When you ordering replacement parts for JT1, refer to this Parts List and quote both part numbers and part names correctly.

1. Structure of Part No.

Yamaha parts are divided largely into two categories; general parts and standard parts, and each part No. has the following structure:

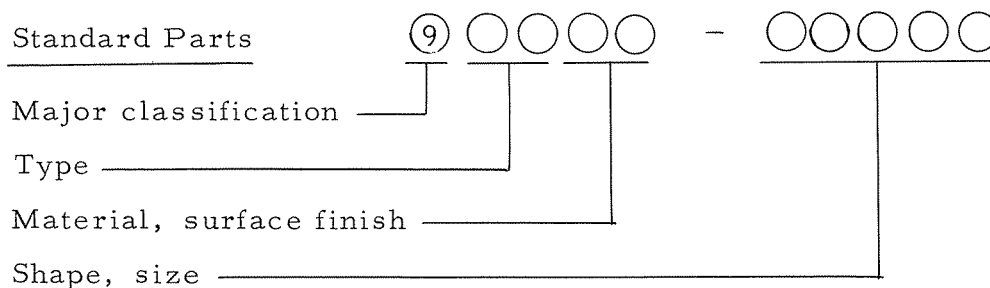
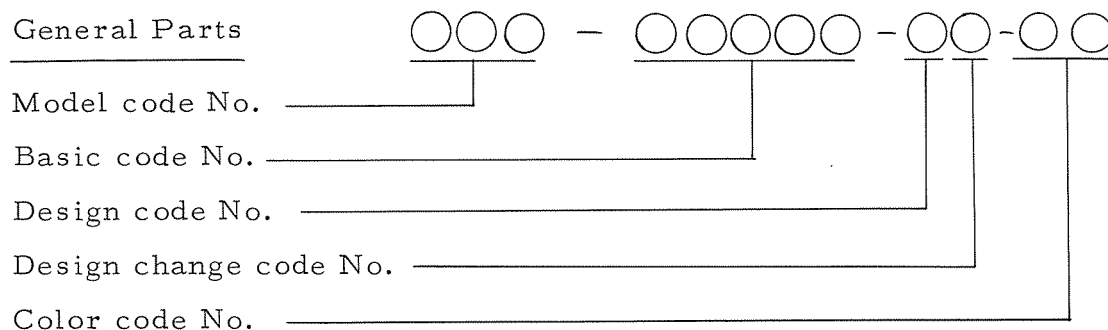

Note: Every standard No. begins with 9.

2. How to Use this Parts List

- (1) Except for steel balls (whose size is indicated in inches), the size of all parts is indicated in millimeters in the following manner.

Pipe (rubber or vinyl) Inside diameter - length

O-ring Sectional area - inside diameter

Washer, shim, collar Inside diameter - outside diameter - thickness (length)

- (2) Parts, which are to be supplied in the form of assemblies, are listed with an indentation of one letter's space, and a dot (.) is put

against the name of each part. If any two different assemblies (e.g., right and left side components) consist of almost the same type components, these two assemblies are listed in two lines, and then the names of component parts are listed in the subsequent lines with an indentation as mentioned earlier. The quantity of parts is given in the following manner; that is, in the case of parts being the same in type between the right and left, a total quantity of parts is given. On the other hand, if the right and left side parts are different in type, the quantity of part(s) on each side is given.

Example

Description	Qt'y
CARBURETOR ASS'Y, left	1
CARBURETOR ASS'Y, right	1
. JET, pilot	2
. NOZZLE, main	2
.	
.	
.	
. LEVER, starter, left	1
. LEVER, starter, right	1

(3) Key to Symbols

- L.H Left hand side (viewed from rider's seat facing forward).
- R.H Right hand side (viewed from rider's seat facing forward).
- S. R Suggested retail price
- U. R Use size (thickness) and/or number as required
- ☆ Government inspected parts
- T Number of teeth in a gear
- V Voltage for light bulbs
- S "S" type oil seal or "S" type circlip
- SD "SD" type oil seal

SO "SO" type oil seal
SW "SW" type oil seal
E "E" type circlip
R "R" type circlip
F/No. . . Frame No. (Applicable machine No.)

(4) The right and left in relation to parts are determined on the basis of the rider facing toward the front.

(5) This Parts List is based on the model in the production line on June 1, 1970. Accordingly, if any modifications which have been made to parts will be announced in the Yamaha Parts News. It is advisable that according to the Yamaha Parts News, You will make necessary corrections to the Parts List on hand to keep it u-dated.



CONTENTS

ENGINE

Fig. 1	Crank Case & Cylinder	1
Fig. 2	Crankcase Cover	5
Fig. 3	Crank & Piston	7
Fig. 4	Clutch	11
Fig. 5	Transmission	13
Fig. 6	Shifter A	17
Fig. 7	Shifter B	19
Fig. 8	Kick	21
Fig. 9	Air Cleaner	23
Fig. 10	Carburetor	25
Fig. 11	Muffler	29
Fig. 12	Oil Pump	31
Fig. 13	Flywheel Magneto	35

CHASSIS

Fig. 14	Frame	39
Fig. 15	Rear Arm & Rear Cushion	41
Fig. 16	Stand & Brake Pedal	43
Fig. 17	Front Fork & Front Fender.....	45
Fig. 18	Steering	49
Fig. 19	Handle & Wire	51
Fig. 20	Fuel Tank	53
Fig. 21	Oil Tank	55
Fig. 22	Seat	57
Fig. 23	Front Wheel	59
Fig. 24	Rear Wheel	61
Fig. 25	Electrical	65

NUMERICAL INDEX



ENGINE

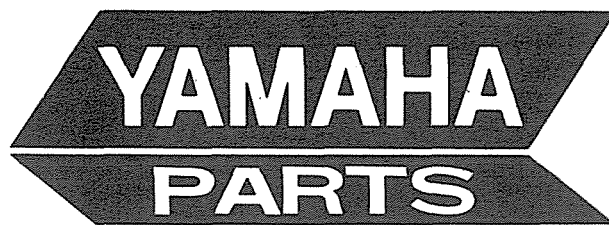
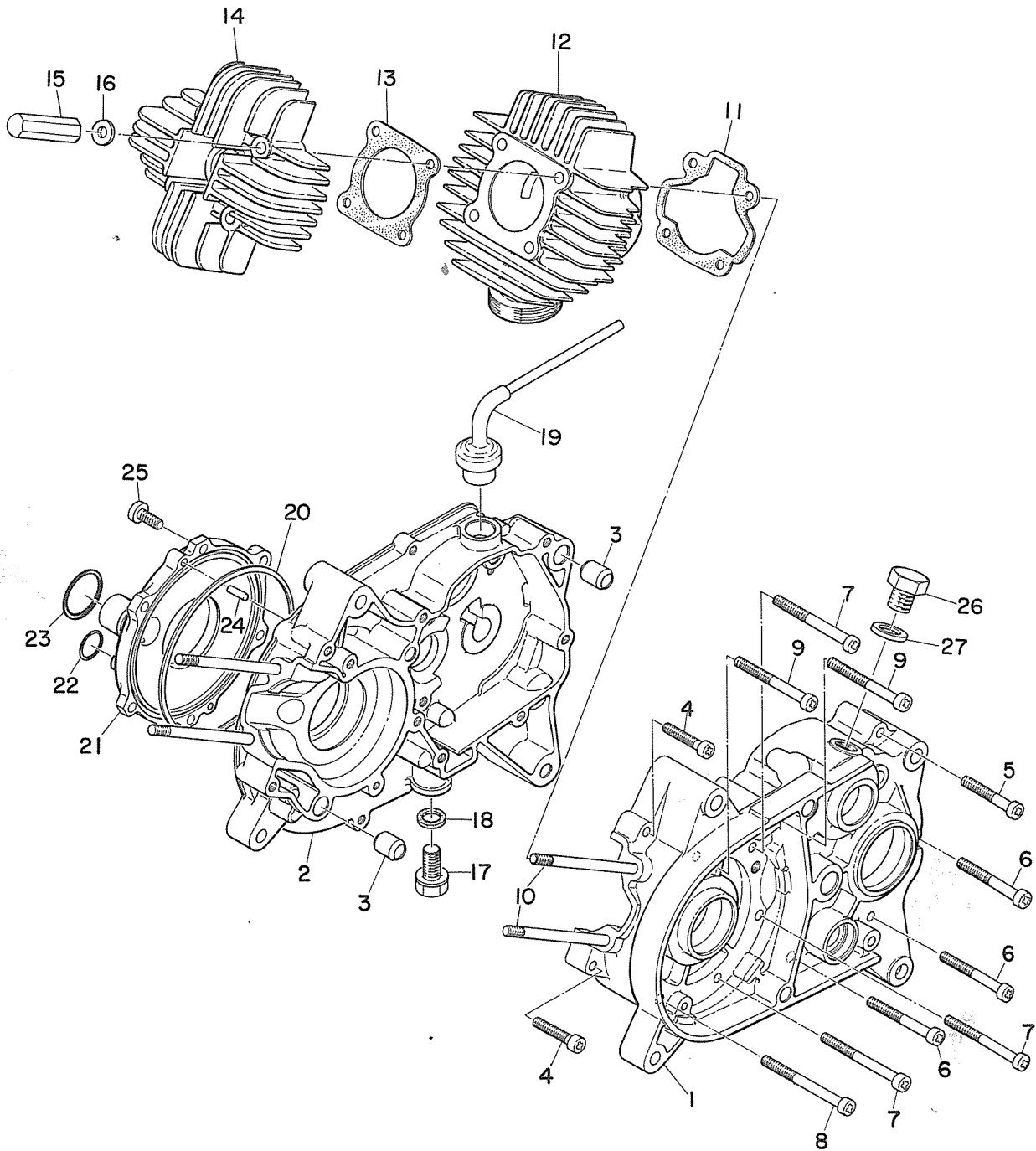





Fig. 1 CRANKCASE & CYLINDER



FWD

CRANKCASE & CYLINDER

Ref. No.	Part No.	Description	Q'ty	Applicable Machine No.	Remarks
1- 1	257-15111-00	CASE, crank left	1		
1- 2	257-15121-00	CASE, crank right	1		
1- 3	91810-08016	PIN, dowel (9.8-12-16)	2		
1- 4	92501-06030	SCREW, pan head	2		
1- 5	92501-06045	SCREW, pan head	1		
1- 6	92501-06050	SCREW, pan head	3		
1- 7	92501-06060	SCREW, pan head	3		
1- 8	92501-06065	SCREW, pan head	1		
1- 9	92501-06055	SCREW, pan head	2		
1-10	109-11361-00	BOLT, cylinder holding	4		
1-11	109-11351-00	GASKET, cylinder	1		
1-12	259-11311-00	CYLINDER	1		
1-13	107-11181-01	GASKET, cylinder head	1		
1-14	259-11111-01-94	HEAD, cylinder	1		
1-15	126-11171-60	NUT, cylinder holding	4		
1-16	92901-06200	WASHER, plain	4		
1-17	132-15351-00	PLUG, drain	1		
1-18	132-15353-00	GASKET, drain plug	1		
1-19	288-15371-00	BREATHER	1		
1-20	180-13554-00	RING, rubber	1		
1-21	257-13551-00	COVER, valve	1		
1-22	93210- ¹²⁰¹⁴ 23029	O-RING (3.53-21.82)	1		
1-23	93210- ²³⁰²⁹ 12014	O-RING (2.62-10.77)	1		
1-24	93604-14012	PIN, dowel (4-13.8)	2		

Fig. 1 CRANKCASE & CYLINDER

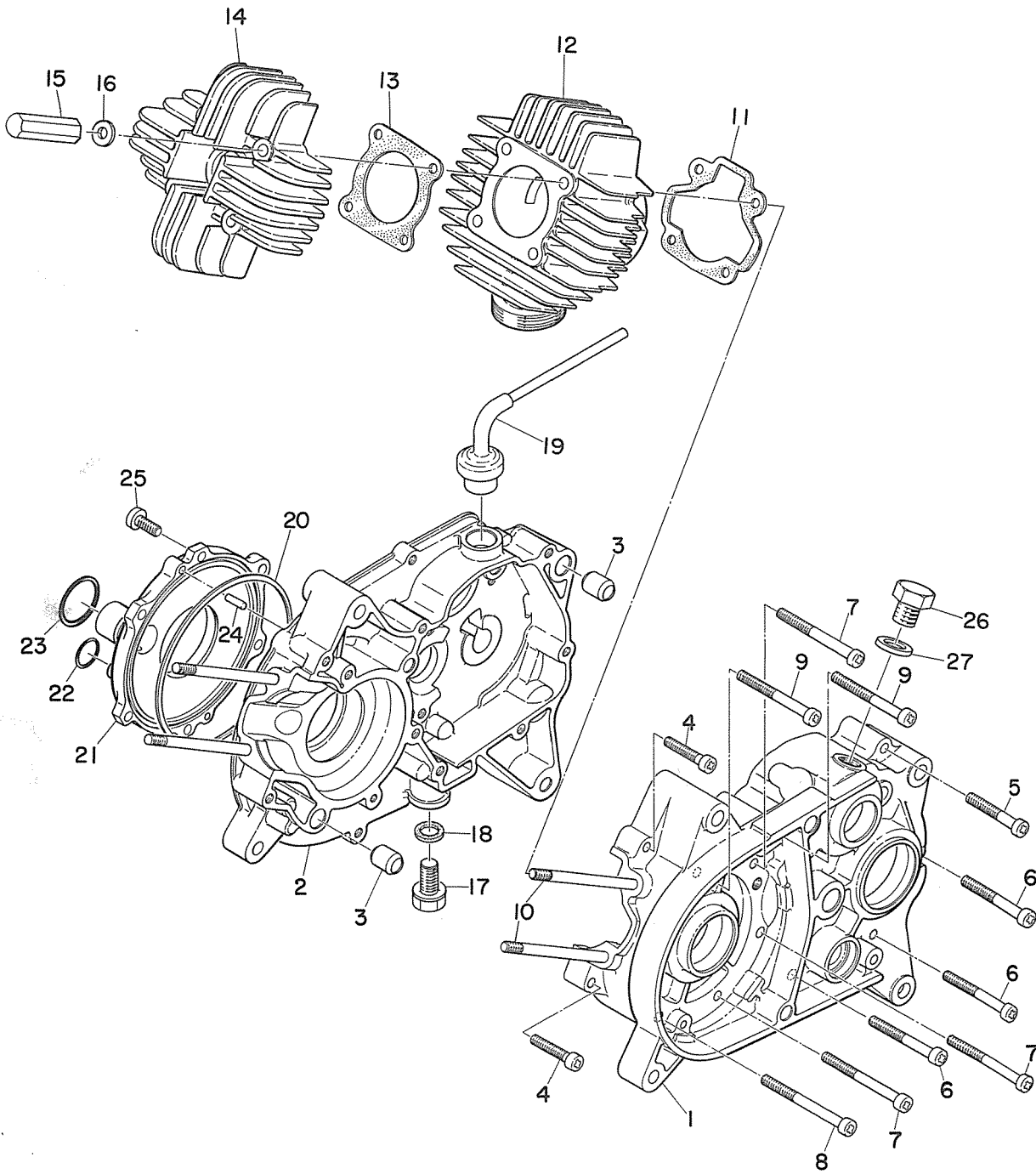

FWD

CRANKCASE & CYLINDER

Ref.No.	Part No.	Description	Q'ty	Applicable Machine No.	Remarks
1-25	92501-06015	SCREW, pan head	6		
1-26	288-18588-00	PLUG, blind	1		
1-27	136-82543-00	GASKET (11.6-18-1)	1		

Fig. 2 CRANKCASE COVER

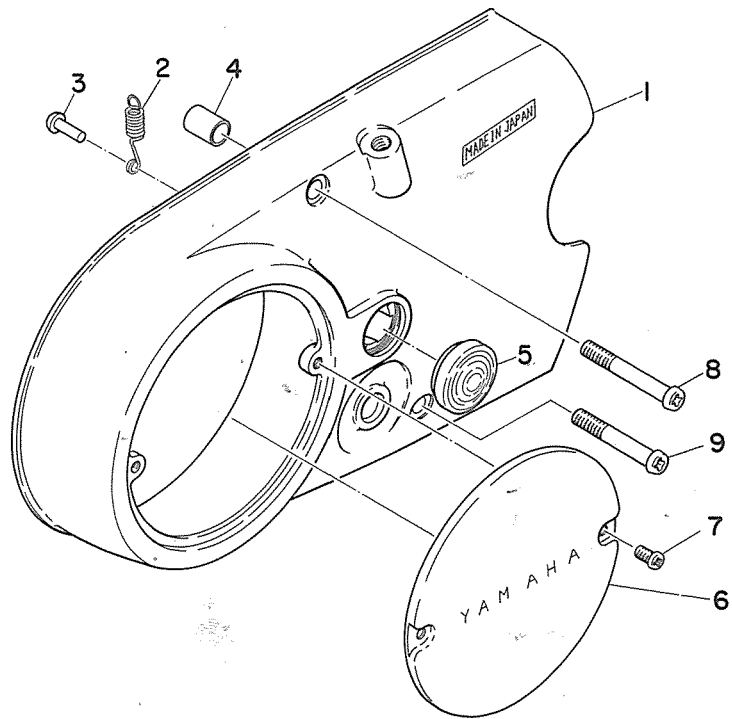
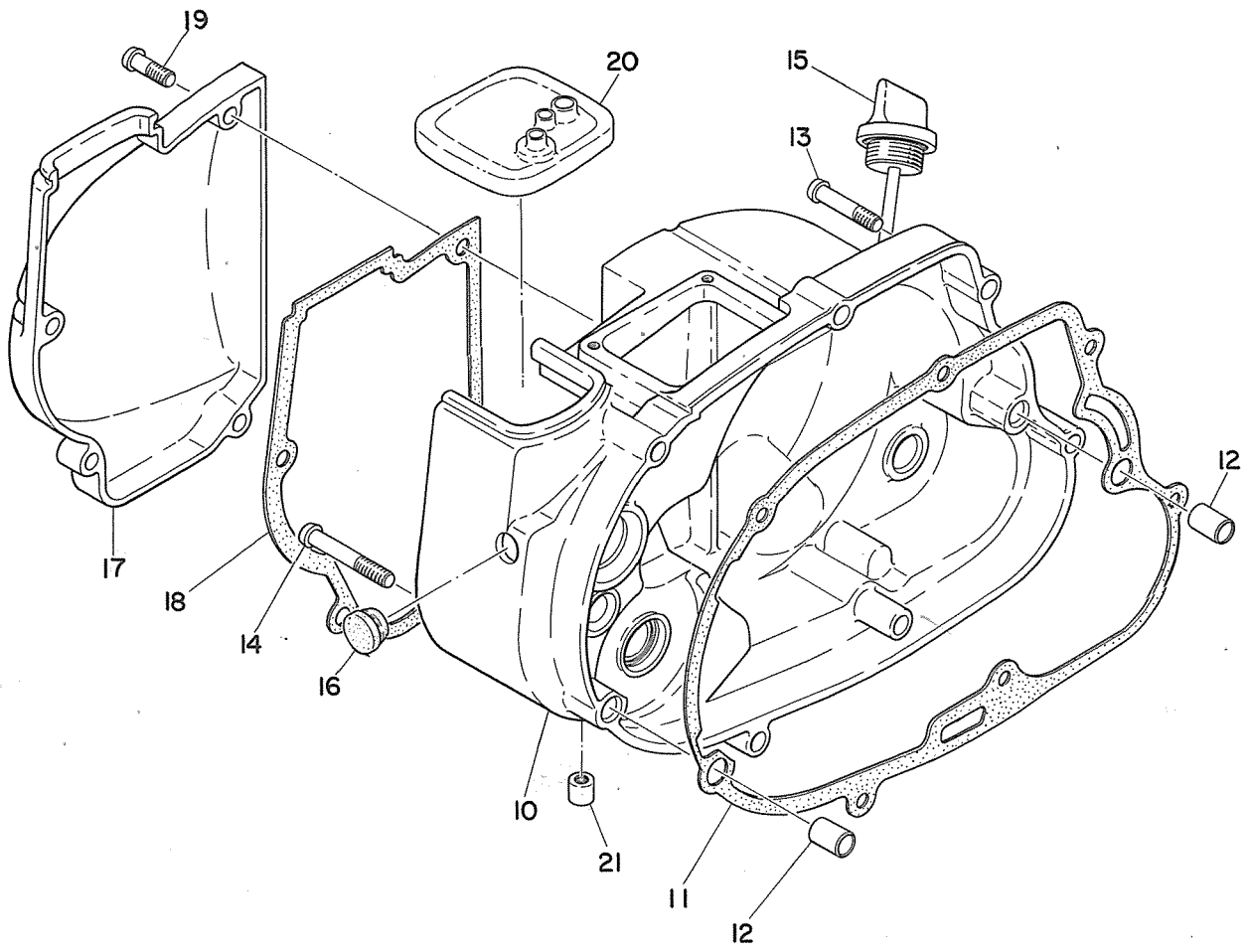

CRANKCASE COVER

Ref. No.	Part No.	Description	Q'ty	Applicable Machine No.	Remarks
2- 1	257-15410-00	CRANKCASE COVER ASS'Y, left	1		
2- 2	257-16345-00	. SPRING, lever return	1		
2- 3	132-16346-00	. HOOK, spring	1		
2- 4	91810-03014	PIN, dowel (8.5-10-14)	2		
2- 5	257-15417-01	COVER, cap	1		
2- 6	164-15415-00	COVER, generator	1		
2- 7	98501-04008	SCREW, pan head	2		
2- 8	92501-06045	SCREW, pan head	2		
2- 9	92501-06040	SCREW, pan head	1		
2-10	257-15421-00	COVER, crankcase, right	1		
2-11	257-15451-00	GASKET, crankcase cover	1		
2-12	91810-03014	PIN, dowel (8.5-10-14)	2		
2-13	92501-06030	SCREW, pan head	6		
2-14	92501-06040	SCREW, pan head	1		
2-15	180-15362-00	PLUG, oil level	1		
2-16	122-15486-00	GROMMET	1		
2-17	257-15413-00	COVER, carburetor	1		
2-18	257-15463-00	GASKET, carburetor cover	1		
2-19	92501-06018	SCREW, pan head	4		
2-20	288-14481-00	CAP, carburetor	1		162/A 8/N25-909-
2-22	288-14485-00	BAND, SPRING	1		26/A "
2-21	257-15433-00	CLEANER, drain	1		

Fig. 3 CRANK & PISTON

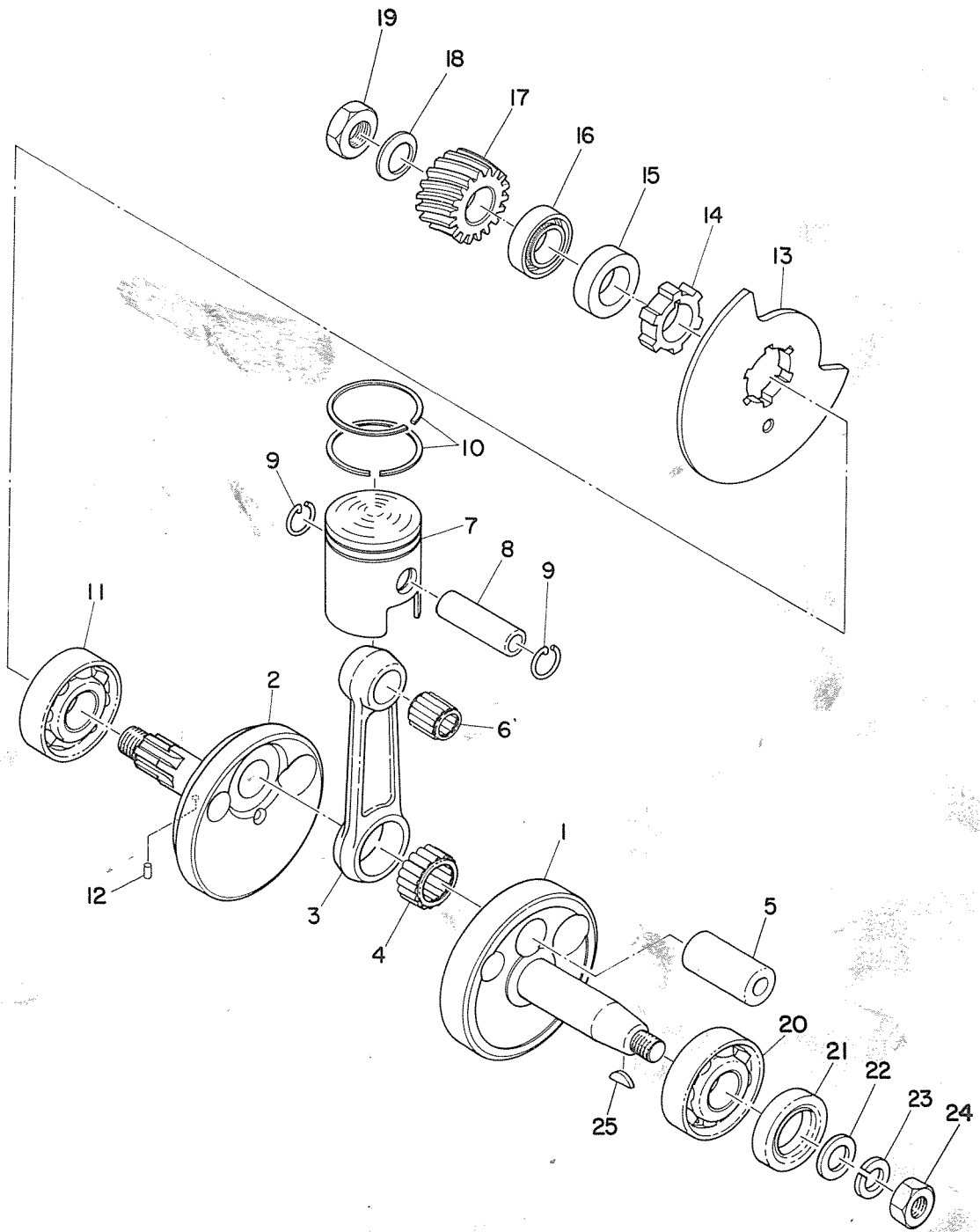

CRANK & PISTON

Ref. No.	Part No.	Description	Q'ty	Applicable Machine No.	Remarks
3- 0-1	259-11400-00	CRANK ASS'Y	1		
3- 1	259-11412-00	. CRANK, left	1		
3- 2	259-11422-00	. CRANK, right	1		
3- 3	126-11651-00	. ROD, connecting	1		
3- 4	93310-41810	. BEARING, con-rod big end	1		
3- 5	257-11681-00	. PIN, crank	1		
3- 6	93310-11202	BEARING, con-rod smallend	1		
3- 7	289-11631-00-96	PISTON (.96)	} U. R. 1	}	} STD
	289-11631-00-97	PISTON (.97)			
	289-11631-00-98	PISTON (.98)			
	289-11631-00-99	PISTON (.99)			
	289-11635-00	PISTON (1st o. s)	1		
	289-11636-00	PISTON (2nd o. s)	1		
3- 8	102-11633-01	PIN, piston	1		
3- 9	132-11634-00	CLIP, piston pin	2		
3-10	113-11601-02	PISTON RING SET	1s		STD
	288-11601-00 288-11601-10-00 113-11601-12	PISTON RING SET (1set o. s)	1s		
	113-11601-22	PISTON RING SET (2nd o. s)	1s		
3-11	93306-30302 ⁰¹	BEARING (6303C3)	1		
3-12	93603-08067	PIN, dowel (3-8)	1		
3-13	257-13512-00	VALVE	1		
3-14	257-13515-00	COLLAR, valve	1		
3-15	257-16136-00	COLLAR, distance	1		
3-16	93103-28012	OIL SEAL (SW-27-47-8)	1		
3-17	257-16111-00	GEAR, primary drive (19T)	1		

Fig. 3 CRANK & PISTON

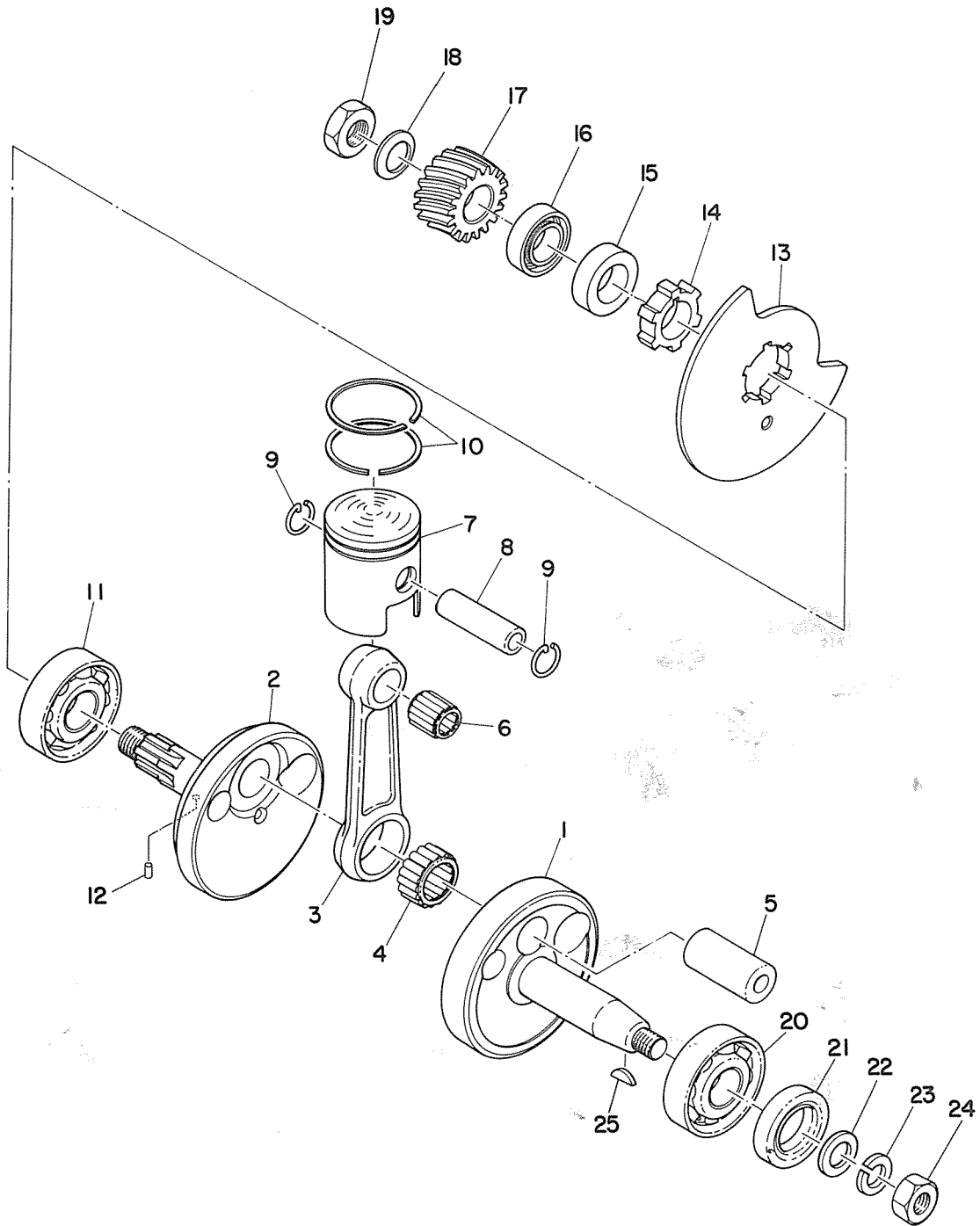

FWD

CRANK & PISTON

Ref. No.	Part No.	Description	Q'ty	Applicable Machine No.	Remarks
3-18	164-16119-00	SPRING, bellevile	1		
3-19	137-16377-00	NUT, clutch boss	1		
3-20	93306-20408	BEARING (6204C3)	1		
3-21	93102-20009	OIL SEAL (SD-20-35-7)	1		
3-22	214-11557-01	WASHER (12.2-22-2.9)	1		
3-23	92901-12100	WASHER, spring	1		
3-24	98801-12200	NUT	1		
3-25	146-11545-00	KEY, woodruff	1		

Fig. 4 CLUTCH

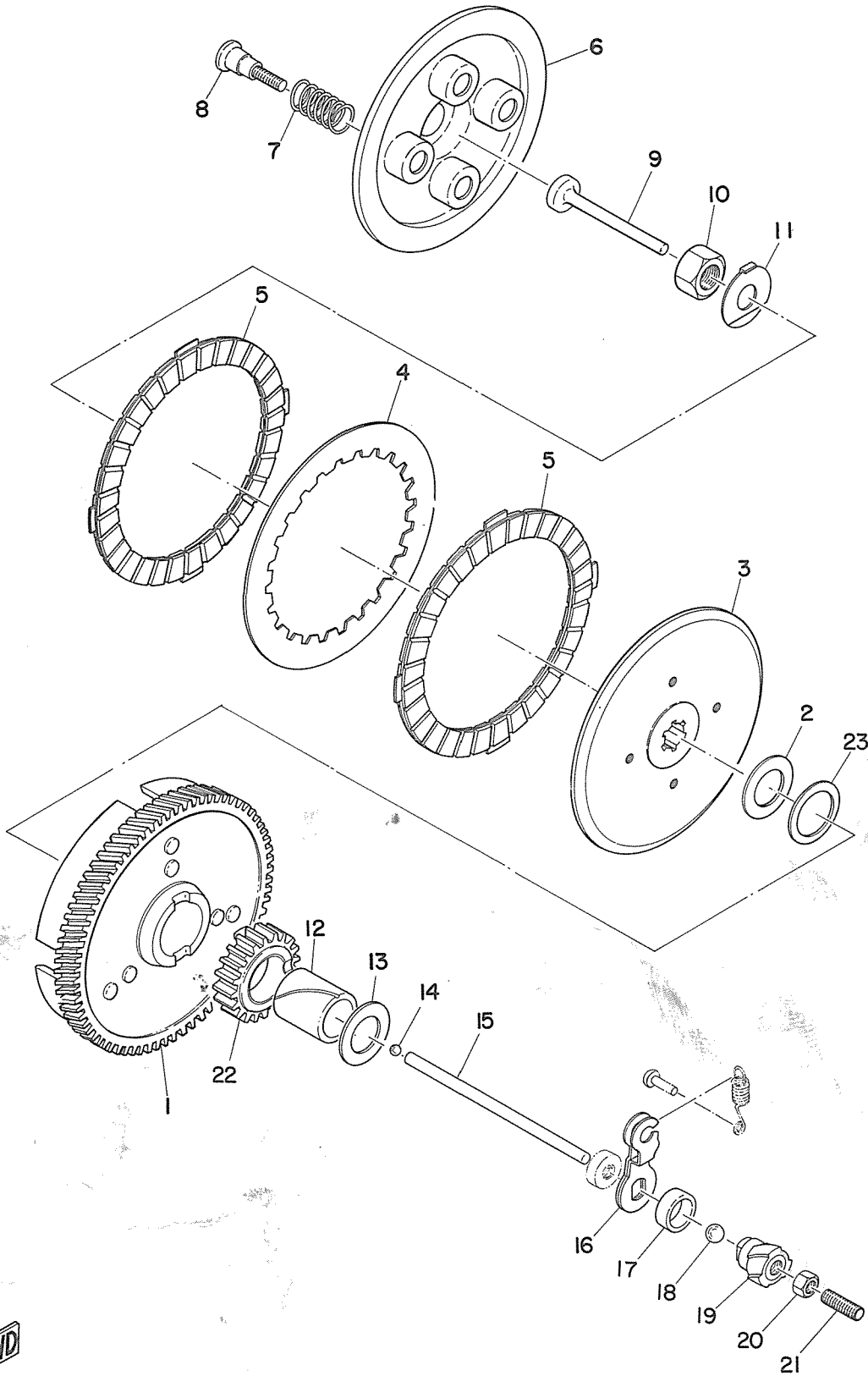

FWD

CLUTCH

Ref. No.	Part No.	Description	Q'ty	Applicable Machine No.	Remarks
4- 0-1	257-16301-01	CLUTCH ASS'Y	1		
4- 1	257-16150-01	. DRIVEN GEAR COMP. (74T)	1		
4- 2	122-16164-00	. PLATE, thrust (17.2-30-2)	1		
4- 3	257-16371-00	. BOSS, clutch	1		
4- 4	257-16324-00	. PLATE, clutch	1		
4- 5	131-16321-00	. PLATE, friction	2		
4- 6	257-16351-00	. PLATE, pressure	1		
4- 7	137-16333-00	. SPRING, clutch	4		
4- 8	137-16337-01	. SCREW, spring	4		
4- 9	137-16356-00	ROD, push 1	1		
4-10	137-16377-00	NUT, clutch boss	1		
4-11	137-16378-00	WASHER, clutch boss	1		
4-12	257-16181-00	SPACER	1		
4-13	122-16164-00	PLATE, thrust (17.2-30-2)	1		
4-14	93503-16003	BALL (3/16 inch)	1		
4-15	257-16357-00	ROD, push 2	1		
4-16	257-16342-00	LEVER, push	1		
4-17	93108-15001	OIL SEAL (OSO-15-22-7)	1		
4-18	93501-04004	BALL (1/4 inch)	1		
4-19	257-16341-00	SCREW, push	1		
4-20	92801-06300	NUT	1		
4-21	257-16343-00	SCREW, adjusting	1		
4-22	164-15631-01	GEAR, kick pinion (19T)	1		
4-23	116-16153-00	WASHER, thrust (23-30-1.5)	1		

Fig. 5 TRANSMISSION

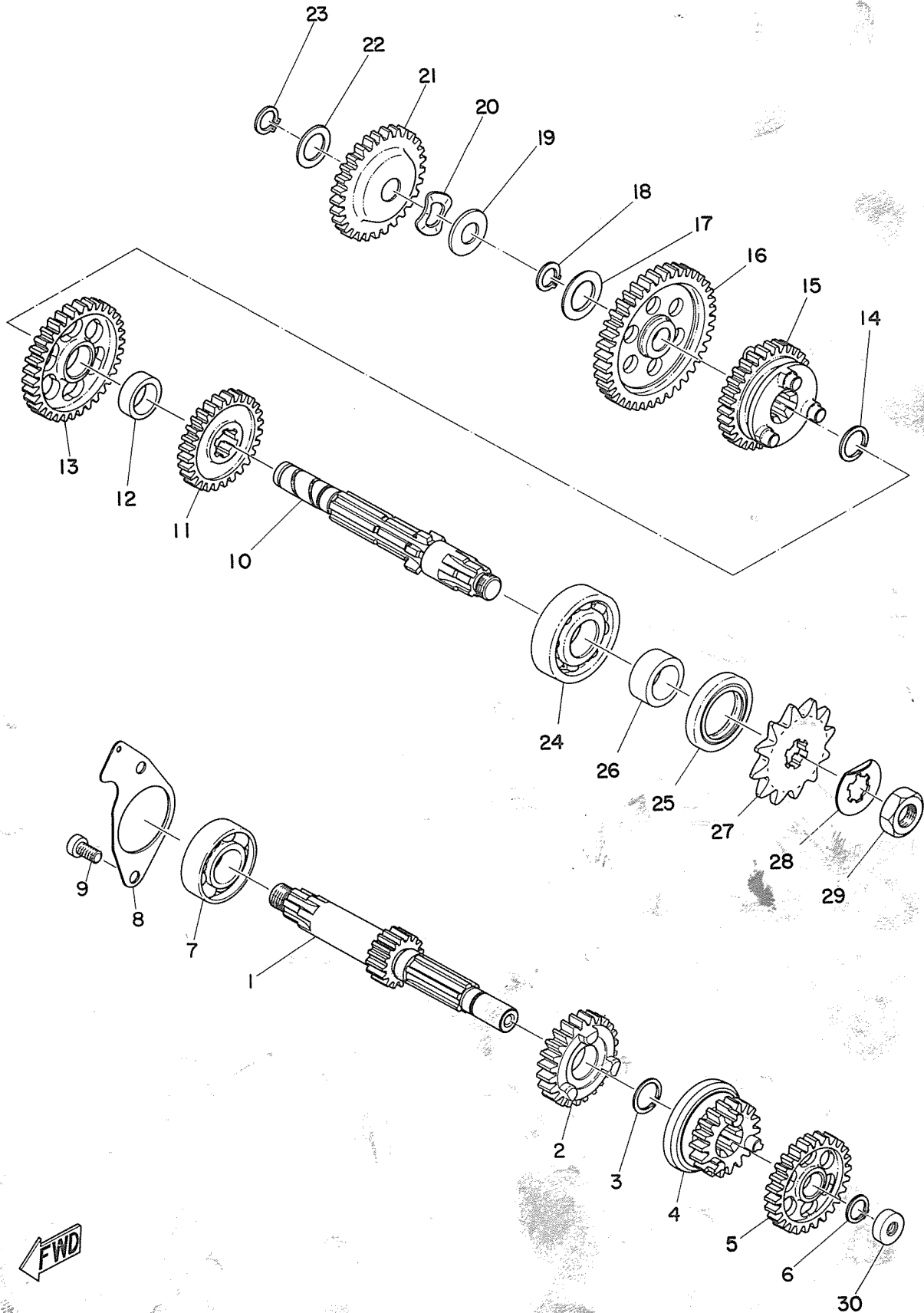

FWD

TRANSMISSION

Ref. No.	Part No.	Description	Q'ty	Applicable Machine No.	Remarks
5- 1	257-17411-01	AXLE, main (13T)	1		
5- 2	257-17131-01	GEAR, 3rd pinion (23T)	1		
5- 3	257-17414-00	CLIP	1		
5- 4	257-17121-00	GEAR, 2nd pinion (18T)	1		
5- 5	257-17141-00	GEAR, 4th pinion (26T)	1		
5- 6	93410-13004	CIRCLIP (S-13)	1		
5- 7	93306-20301	BEARING (6203)	1		
5- 8	257-17471-00	PLATE, bearing cover	1		
5- 9	92501-06012	SCREW, pan head	2		
5-10	257-17421-01	AXLE, drive	1		
5-11	257-17241-00	GEAR, 4th wheel (27T)	1		
5-12	257-17258-00	COLLAR, distance	1		
5-13	257-17221-01	GEAR, 2nd wheel (34T)	1		
5-14	257-17414-00	CLIP	1		
5-15	257-17231-00	GEAR, 3rd wheel (30T)	1		
5-16	257-17211-00	GEAR, 1st wheel (40T)	1		
5-17	257-17219-00-06	SHIM (13.2-24-0.6)	1		
5-18	93410-13004	CIRCLIP (S-13)	1		
5-19	201-15653-00	WASHER, thrust (13.2-23-1)	1		
5-20	137-15643-00	WASHER, wave	1		
5-21	257-15651-00	GEAR, kick idle (28T)	1		
5-22	132-15653-00-10	WASHER, thrust (13.3-22-1.0)	} U. R. 1		
	132-15653-00-12	WASHER, thrust (13.3-22-1.2)			
	132-15653-00-14	WASHER, thrust (13.3-22-1.4)			

Fig. 5 TRANSMISSION

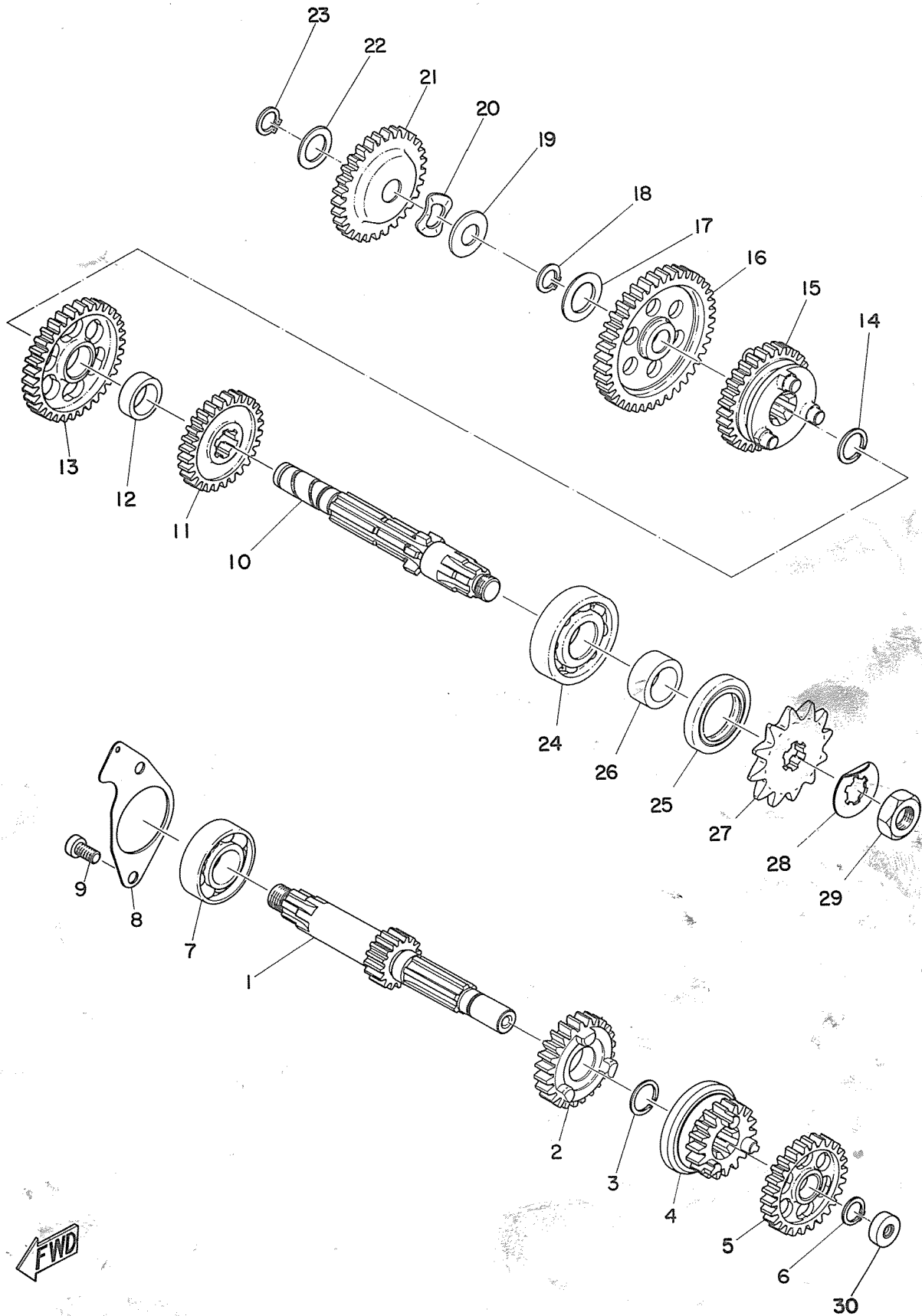

FWD

TRANSMISSION

Ref. No.	Part No.	Description	Q'ty	Applicable Machine No.	Remarks
5-23	93410-13004	CIRCLIP (S-13)	1		
5-24	93306-30305	BEARING (6303)	1		
5-25	93102-25017	OIL SEAL (SD-25-40-5)	1		
5-26	257-17462-00	COLLAR, distance	1		
5-27	257-17461-20	SPROCKET, drive (12T)	} U. R 1		STD
	257-17461-30	SPROCKET, drive (13T)			
	257-17461-40	SPROCKET, drive (14T)			
	257-17461-50	SPROCKET, drive (15T)			
5-28	257-17464-00	WASHER, lock	1		
5-29	257-17463-00	NUT, lock	1		
5-30	257-15389-00	SEAL, push rod	1		

Fig. 6 SHIFTER A

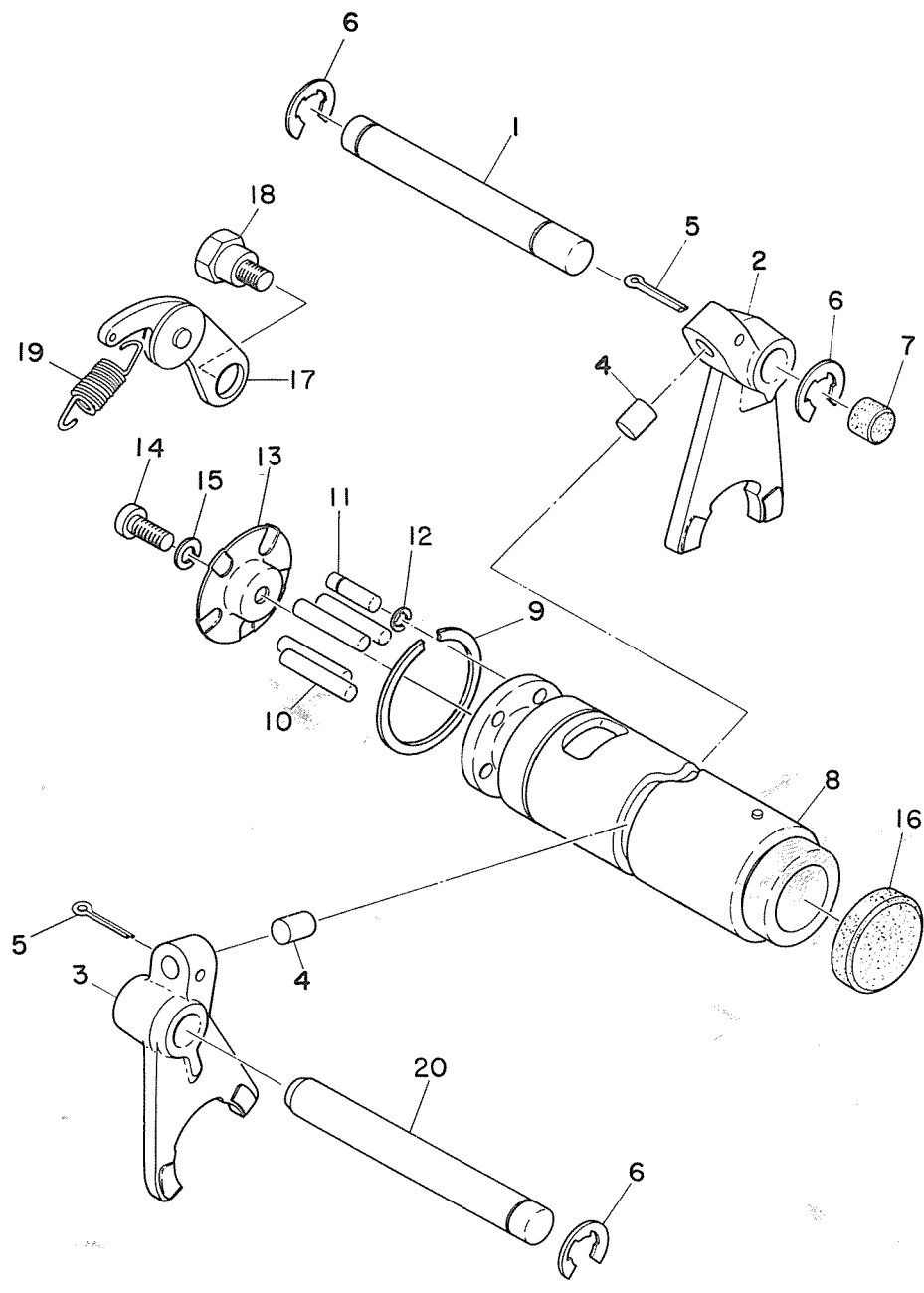

FWD

SHIFTER A

Ref. No.	Part No.	Description	Q'ty	Applicable Machine No.	Remarks
6- 1	257-18534-00	BAR, shift fork guide	1		
6- 2	259-18511-00	FORK, shift 1	1		
6- 3	257-18512-00	FORK, shift 2	1		
6- 4	257-18552-00	PIN, cam follower	2		
6- 5	91401-25017	PIN, cotter	2		
6- 6	93430-08006	CIRCLIP (E-8)	3		
6- 7	150-18328-00	PLUG, blind	1		
6- 8	257-18541-60	CAM, shaft	1		
6- 9	93440-32017	CIRCLIP	1		
6-10	93604-22050	PIN, dowel (4-21.8)	4		
6-11	174-18544-00	PIN, locating	1		
6-12	93430-03014	CIRCLIP (E-2.5)	1		
6-13	164-18561-00	PLATE, side	1		
6-14	98501-05012	SCREW, pan head	1		
6-15	92901-05100	WASHER, spring	1		
6-16	257-18589-00	PLUG, blind	1		
6-17	132-18140-00	STOPPER LEVER ASS'Y	1		
6-18	132-18177-00	BOLT, stopper	1		
6-19	132-18143-00	SPRING, stopper	1		
6-20	257-18531-00	BAR, shift fork guide	1		

Fig. 7 SHIFTER B

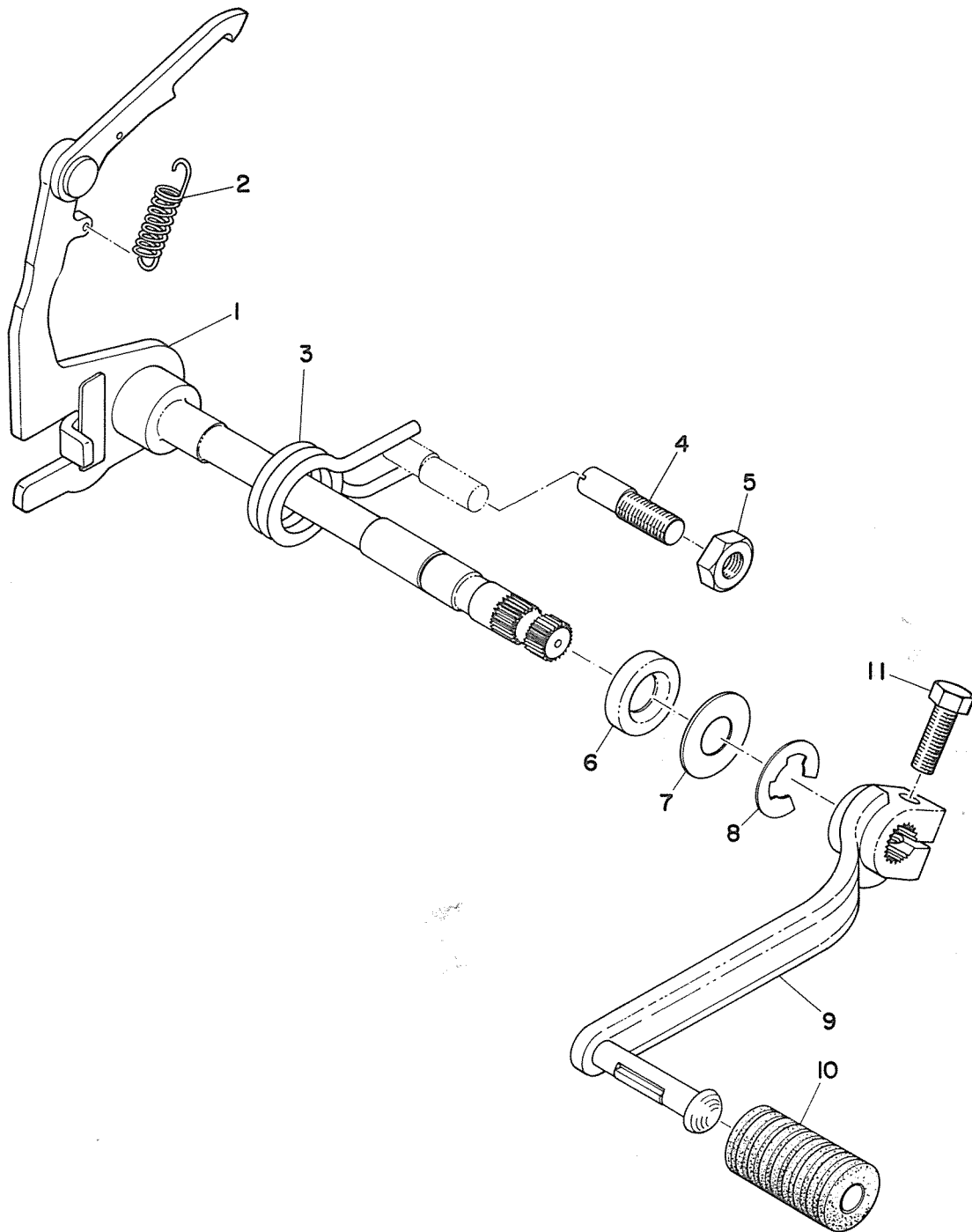

SHIFTER B

Ref. No.	Part No.	Description	Q'ty	Applicable Machine No.	Remarks
7- 1	257-18101-00	CHANGE SHAFT ASS'Y	1		
7- 2	132-18123-00	. SPRING, shift arm	1		
7- 3	132-18124-00	SPRING, shaft return	1		
7- 4	132-18133-00	SCREW, adjusting	1		
7- 5	98800-08100	NUT	1		
7- 6	93101-12004	OIL SEAL (S-12-22-5)	1		
7- 7	132-18137-00	WASHER, change axle (14.1-28-1.6) 1			
7- 8	93430-10016	CIRCLIP (E-10)	1		
7- 9	248-18111-00-93	PEDAL, change	1		
7-10	132-18113-01	COVER, change pedal	1		
7-11	91201-06020	BOLT	1		

Fig. 8 KICK

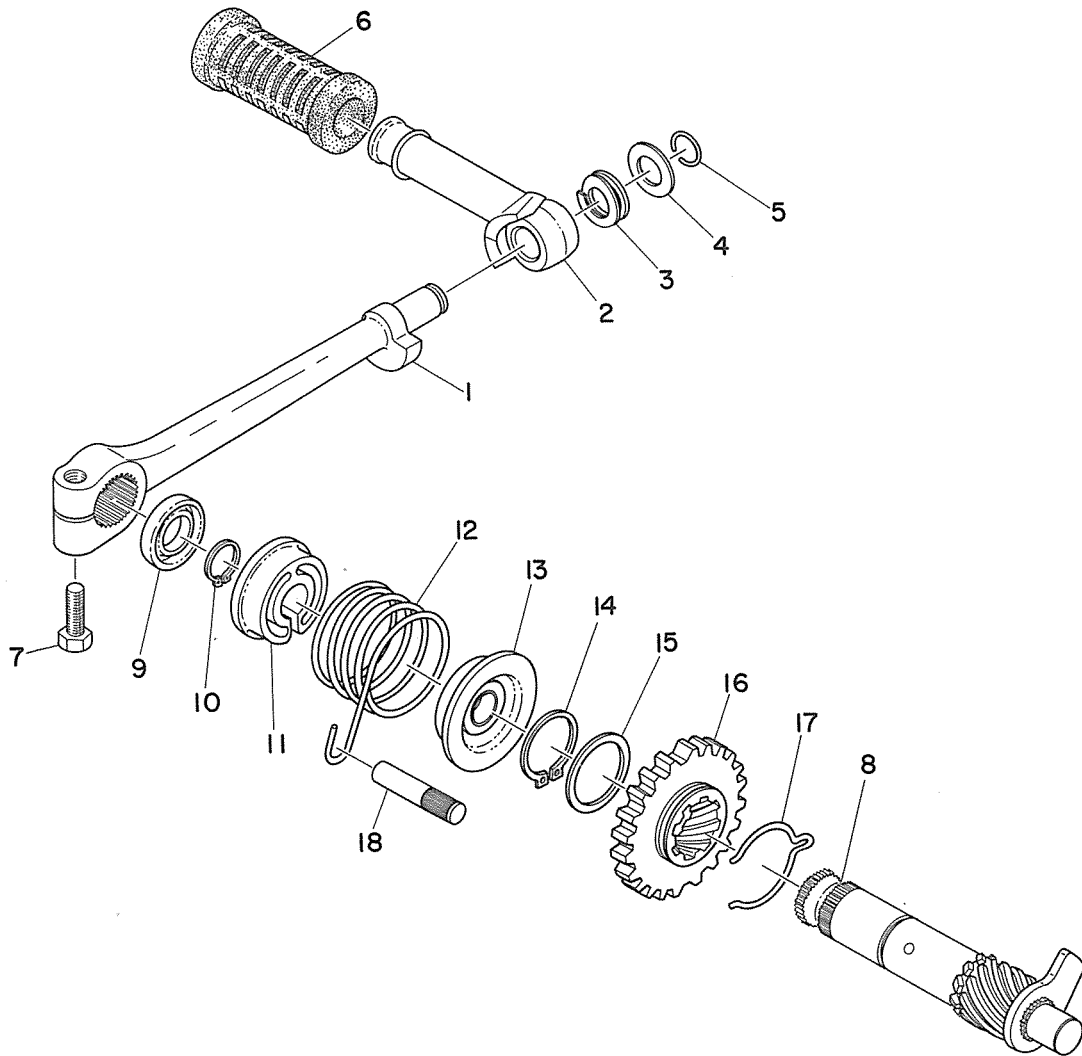

KICK

Ref. No.	Part No.	Description	Q'ty	Applicable Machine No.	Remarks
8- 0-1	276-15610-00-93	KICK CRANK ASS'Y	1		
8- 1	276-15611-00	. CRANK, kick	1		Not for sale
8- 2	122-15612-01	. LEVER, kick	1		
8- 3	214-15625-00	. SPRING, kick crank	1		
8- 4	132-15616-00	. WASHER, kick lever	1		
8- 5	132-15617-00	. CLIP, kick lever	1		
8- 6	156-15618-01	COVER, kick lever	1		
8- 7	91101-06020	BOLT	1		
8- 8	180-15660-00	KICK AXLE ASS'Y	1		
8- 9	93109-15001	OIL SEAL (SDO-15-26-6)	1		
8-10	93410-15005	CIRCLIP (S-15)	1		
8-11	132-15676-00	COVER, kick spring	1		
8-12	132-15665-00	SPRING, kick	1		
8-13	132-15664-00	GUIDE, kick spring	1		
8-14	93410-25017	CIRCLIP (S-25)	1		
8-15	117-15644-00	SHIM (25.1-32-1)	1		
8-16	180-15641-00	GEAR, kick (28T)	1		
8-17	180-15687-00	CLIP, kick	1		
8-18	257-15668-00	STOPPER, kick spring	1		

Fig. 9 AIR CLEANER

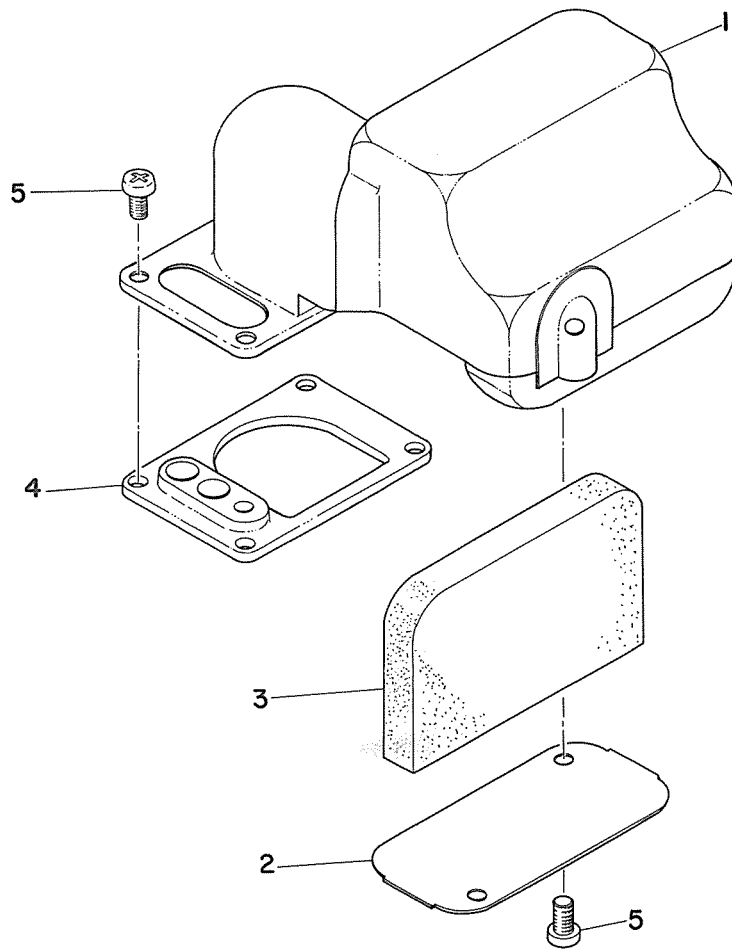

AIR CLEANER

Ref. No.	Part No.	Description	Q'ty	Applicable Machine No.	Remarks
9- 1	288-14411-00	CASE, air cleaner	1		
9- 2	288-14412-00	CAP, case	1		
9- 3	288-14451-00	ELEMENT, air cleaner	1		
9- 4	288-14453-00	JOINT, air cleaner	1		
9- 5	98501-04008	SCREW, pan head	6		

Fig. 10 CARBURETOR

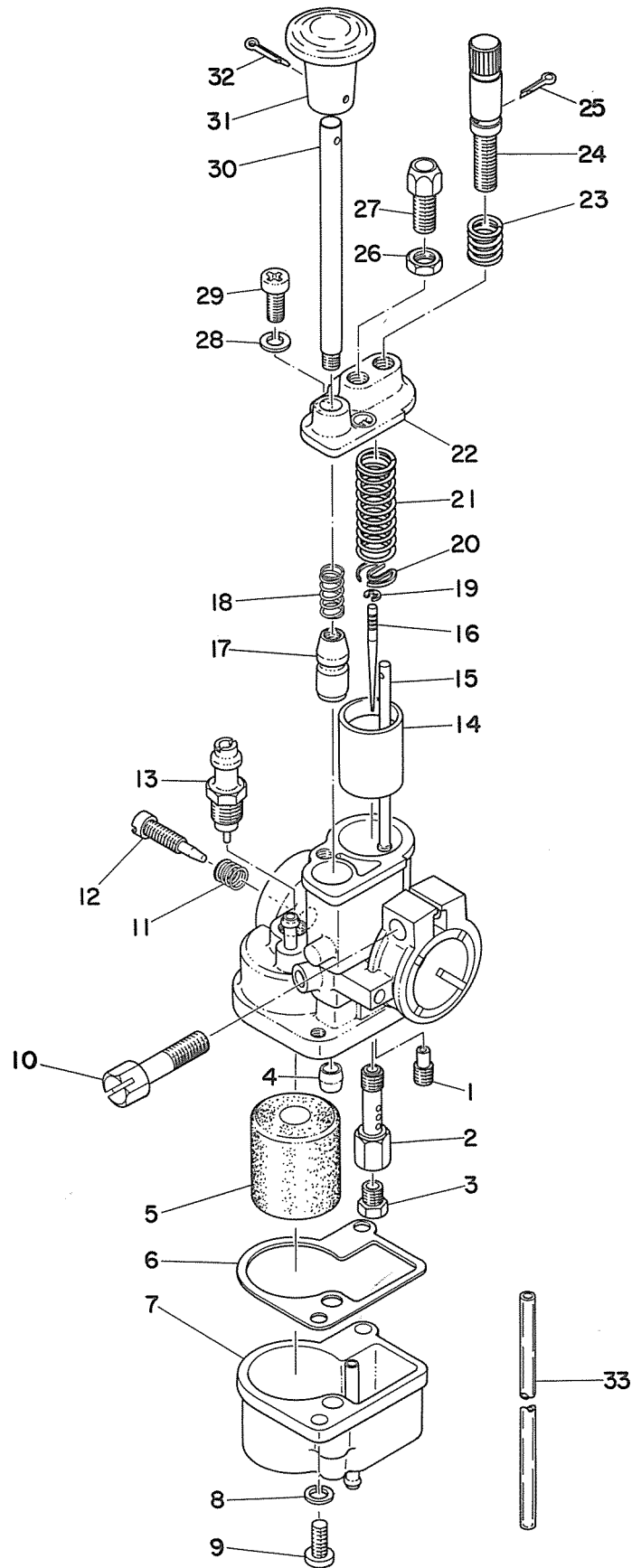

CARBURETOR

Ref. No.	Part No.	Description	Q'ty	Applicable Machine No.	Remarks
10- 0-1	288-14301-00	CARBURETOR ASS'Y	1		
10- 1	288-14342-38	. JET, pilot (#38)	1		
10- 2	288-14341-00	. NOZZLE, main	1		
10- 3	288-14343-42	. JET, main (#84)	1		
	288-14343-43	. JET, main (#86)	1		STD
	288-14343-44	. JET, main (#88)	1		
10- 4	288-14344-25	. JET, starter (#50)	1		
10- 5	288-14385-00	. FLOAT	1		
10- 6	288-14384-00	. GASKET	1		
10- 7	288-14381-00	. BODY, float chamber	1		
10- 8	92901-04100	. WASHER, spring	2		
10- 9	98501-04010	. SCREW, pan head	2		
10-10	288-14125-00	. SCREW, body fitting	1		
10-11	288-14334-00	. SPRING, air adjusting	1		
10-12	288-14323-00	. SCREW, air adjusting	1		
10-13	288-14390-10	. VALVE SEAT ASS'Y (#1.0)	1		
10-14	288-14312-15	. VALVE, throttle (#6.5)	1		
10-15	288-14314-00	. BAR, throttle	1		
10-16	288-14336-00	. NEEDLE	1		
10-17	288-14371-00	. PLUNGER STARTER ASS'Y	1		
10-18	288-14335-00	. SPRING, plunger	1		
10-19	288-14137-00	. CLIP	1		
10-20	288-14136-00	. SEAT, spring	1		
10-21	288-14331-00	. SPRING, throttle valve	1		

Fig. 10 CARBURETOR

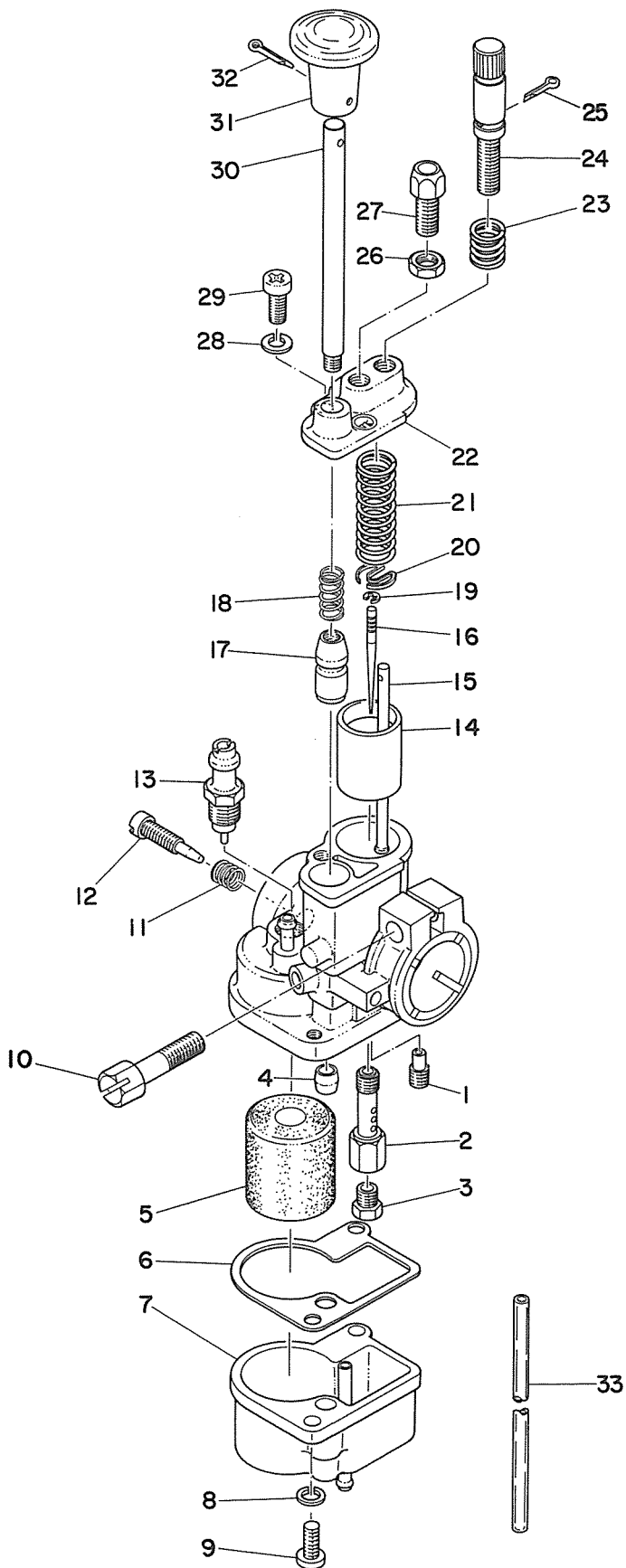

FWD

CARBURETOR

Ref. No.	Part No.	Description	Q'ty	Applicable Machine No.	Remarks
10-22	288-14158-00	. TOP, mixing chamber	1		
10-23	288-14333-00	. SPRING, throttle stop	1		
10-24	288-14321-00	. SCREW, throttle	1		
10-25	91401-12010	. PIN, cotter	1		
10-26	288-14161-00	. NUT, wire adjusting	1		
10-27	288-14124-00	. SCREW, wire adjusting	1		
10-28	92901-04100	. WASHER, spring	1		
10-29	98501-04010	. SCREW, pan head	1		
10-30	288-14379-00	. ROD, starter	1		
10-31	288-14118-00	KNOB, starter	1		
10-32	91401-16012	. PIN, cotter	1		
10-33	288-14197-00	PIPE, air vent	1		

Fig. 11 MUFFLER

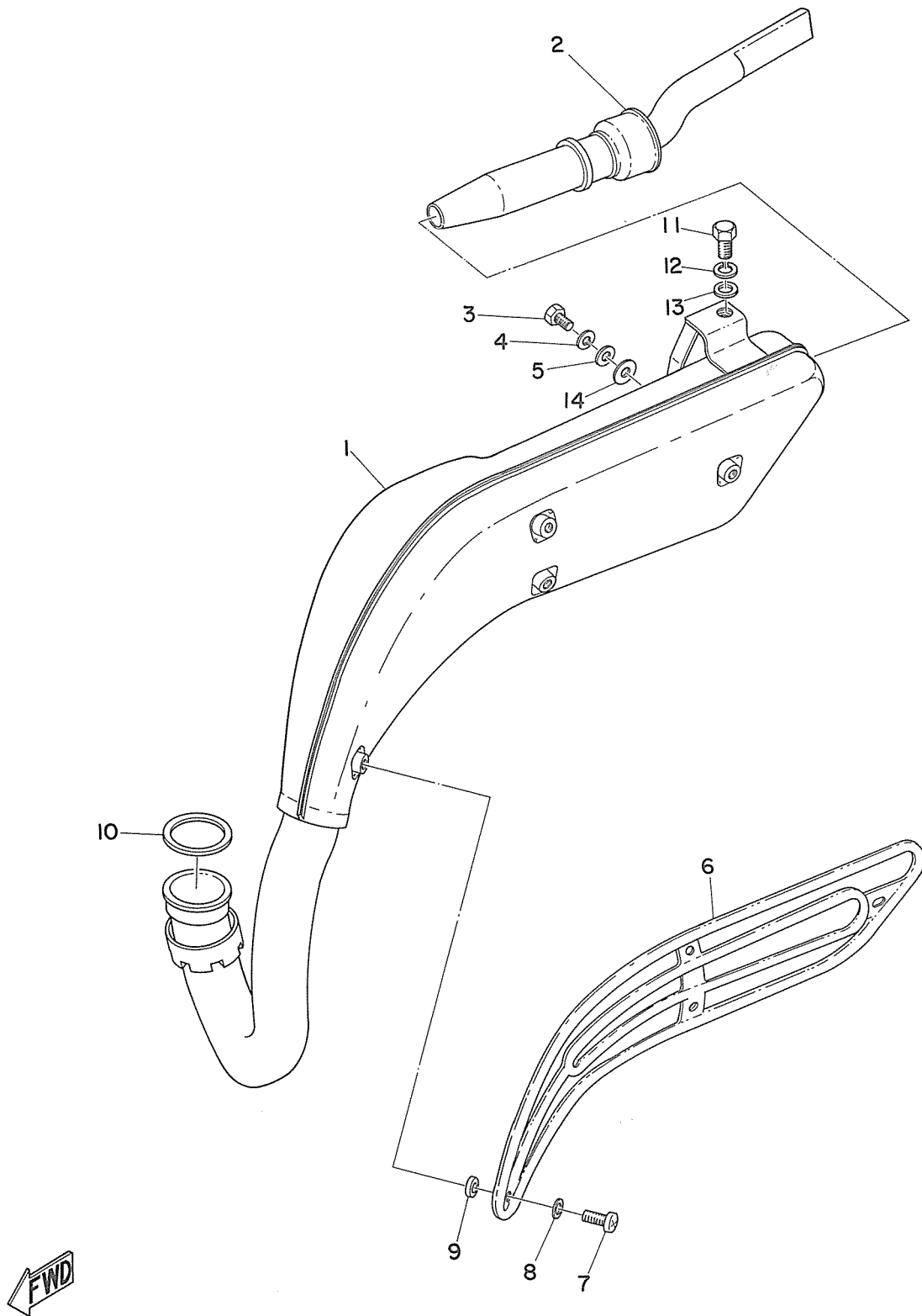

MUFFLER

Ref. No.	Part No.	Description	Q'ty	Applicable Machine No.	Remarks
11- 1	288-14610-30	EXHAUST PIPE ASS'Y	1		
11- 2	288-14752-30	. PIPE, outlet	1		
11- 3	91201-06015	. BOLT	1		
11- 4	92901-06100	. WASHER, spring	1		
11- 5	136-22316-00	. WASHER, chain case (6.5-15-1.2)	1		
11- 6	288-14718-30	PROTECTOR, muffler	1		
11- 7	91903-06010	SCREW, bind	4		
11- 8	178-14766-00	WASHER, protector (6.2-12-3.0)... ..	4		
11- 9	214-14766-00	WASHER, protector (6.2-12-1.5)... ..	4		
11-10	132-14613-00	GASKET, exhaust	1		
11-11	97201-08012	BOLT	1		
11-12	92901-08100	WASHER, spring	1		
11-13	92901-08200	WASHER, plain	1		
11-14	288-14623-00	GASKET	1		

Fig. 12 OIL PUMP

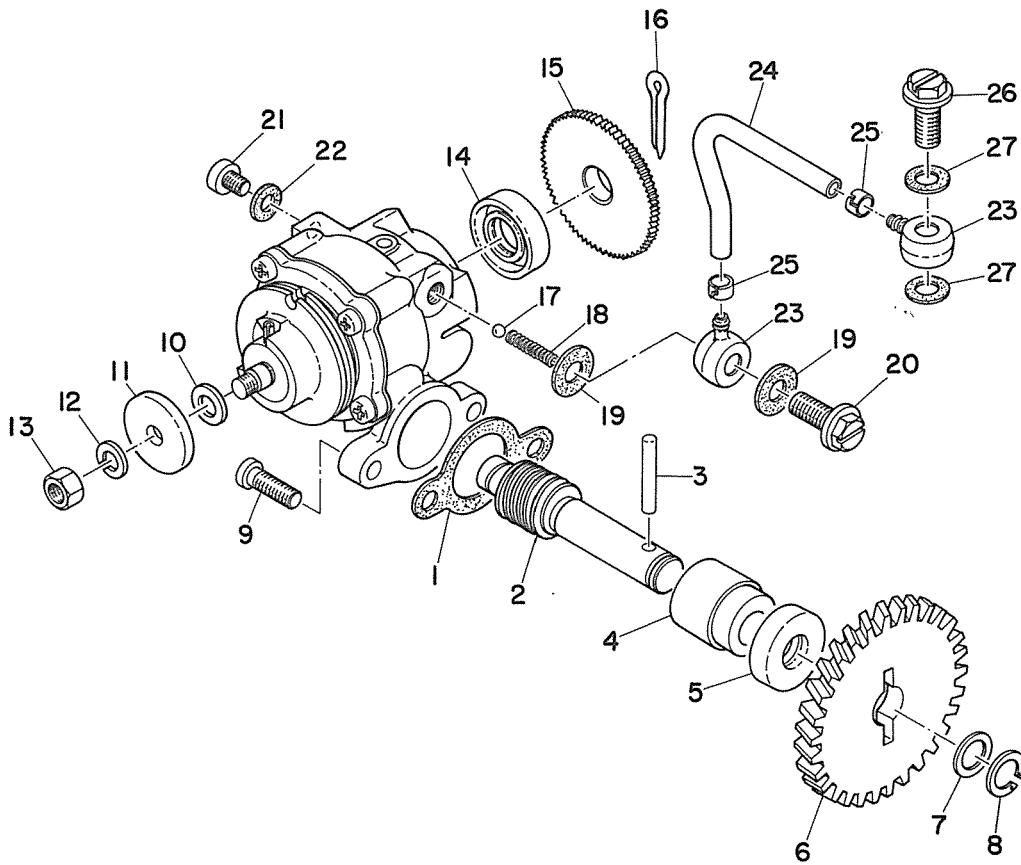

OIL PUMP

Ref. No.	Part No.	Description	Q'ty	Applicable Machine No.	Remarks
12- 1	126-13116-00	GASKET, pump case	1		
12- 2	257-13175-00	SHAFT, worm	1		
12- 3	93603-22028	PIN, dowel	1		
12- 4	137-13176-00	METAL, worm shaft outer	1		
12- 5	93101-10001	OIL SEAL (S-10-21-5)	1		
12- 6	257-13178-00	GEAR, drive (30T).....	1		
12- 7	101-18137-00	WASHER (10.5-20-1.0)	1		
12- 8	93440-08001	CIRCLIP	1		
12- 9	98501-05015	SCREW, pan head	2		
12- 0-1	257-13101-00	OIL PUMP ASS'Y	1		
12-10	137-13137-00	. SHIM, plunger (5.8-10-0.1)	1		
12-11	137-13138-01	. PLATE, adjusting	1		
12-12	92901-05100	. WASHER, spring	1		
12-13	98801-05200	. NUT	1		
12-14	93101-10001	. OIL SEAL (S-10-21-5)	1		
12-15	137-13128-00	. PLATE, starter	1		
12-16	91401-12018	. PIN, cotter	1		
12-17	93505-32002	. BALL (5/32 inch)	1		
12-18	137-13169-00	. SPRING, check ball	1		
12-19	137-13167-00	. GASKET, banjo bolt	2		
12-20	137-13165-00	. BOLT, banjo	1		
12-21	98901-04008	. SCREW, bind	1		
12-22	137-13187-00	. GASKET, breather	1		
12-23	214-13162-00	. BANJO	2		

Fig. 12 OIL PUMP

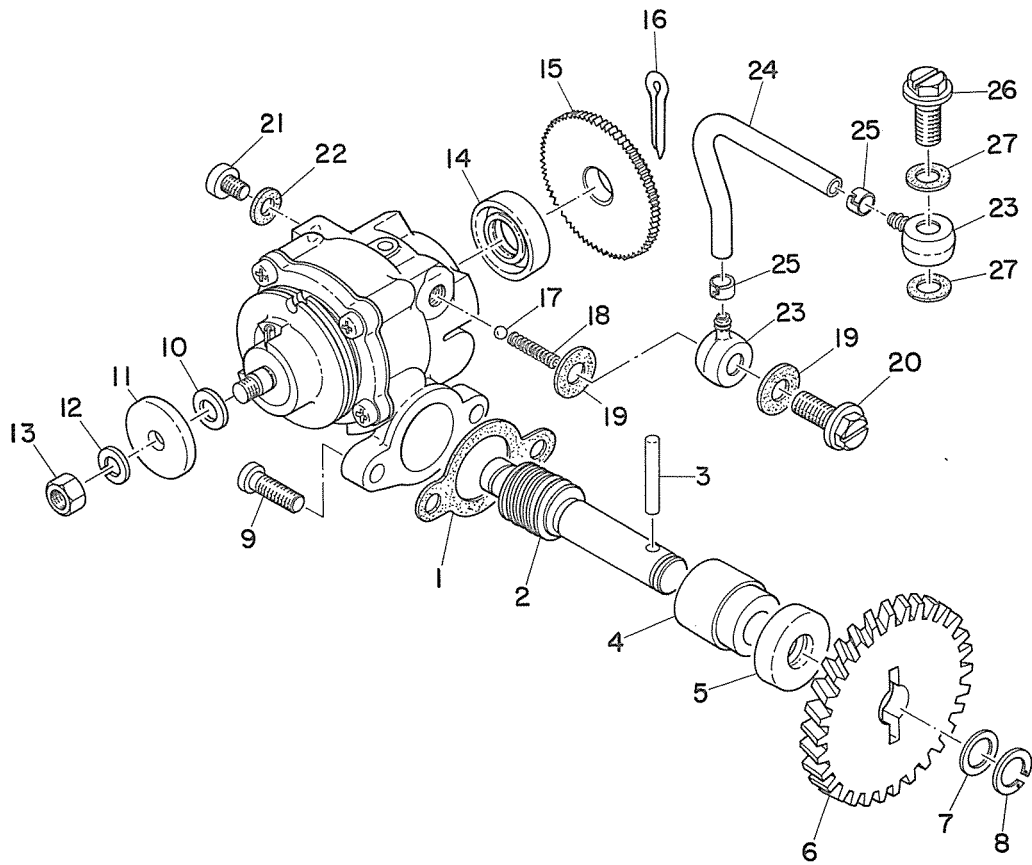

OIL PUMP

Ref. No.	Part No.	Description	Q'ty	Applicable Machine No.	Remarks
12-24	257-13161-00	. PIPE, delivery	1		
12-25	214-13164-00	. CLIP, delivery pipe	2		
12-26	137-13165-00	BOLT, banjo	1		
12-27	137-13167-00	GASKET, banjo	2		

Fig. 13 FLYWHEEL MAGNETO

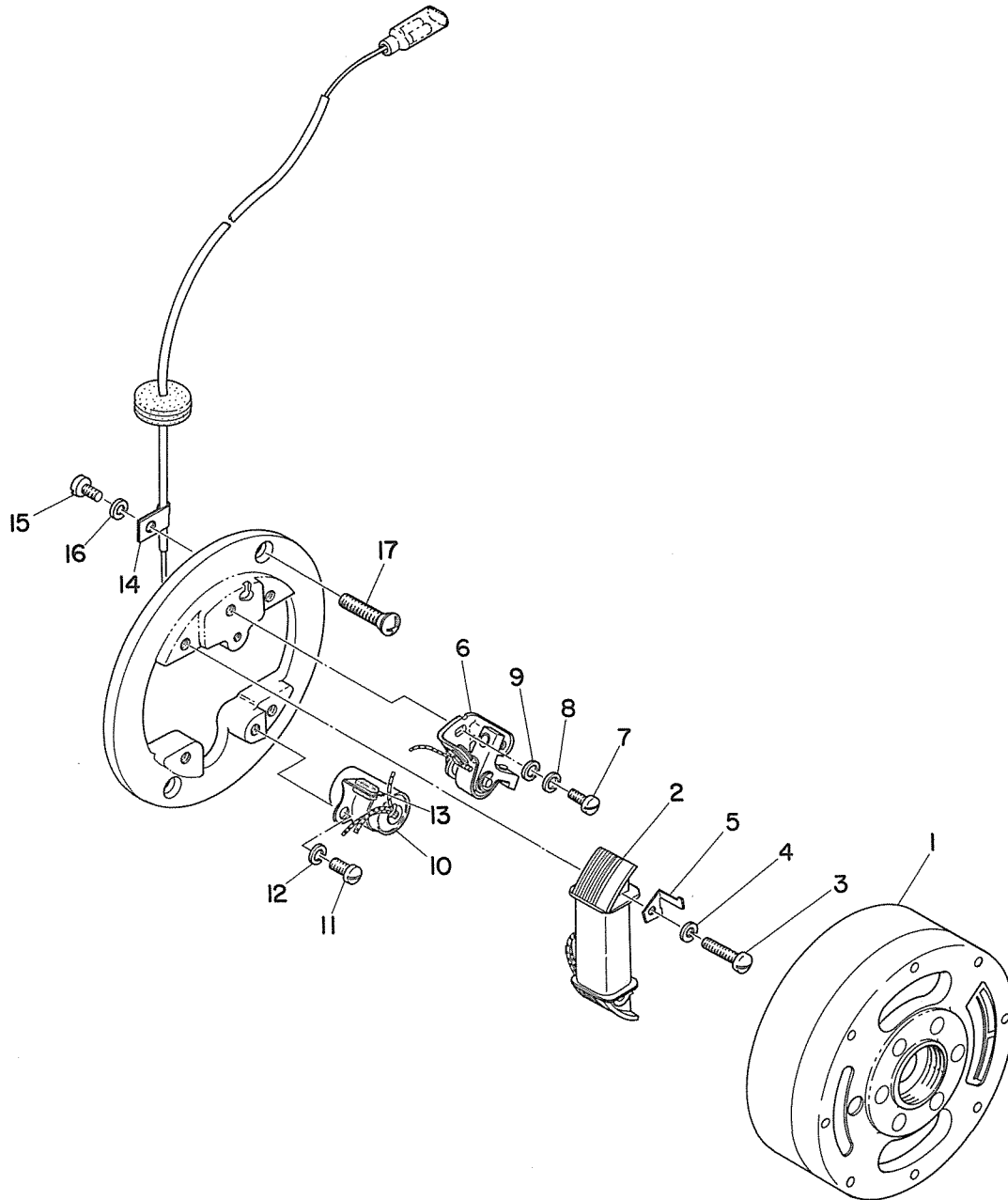

FLYWHEEL MAGNETO

Ref. No.	Part No.	Description	Q'ty	Applicable Machine No.	Remarks
13- 0-1	288-81300-10	FLYWHEEL MAGNETO ASS'Y 1		
13- 1	207-81350-10	. ROTOR ASS'Y 1		
13- 2	207-81312-10	. COIL, source 1		
13- 3	110-81348-20	. SCREW, pan head (4-25) 2		
13- 4	92901-04100	. WASHER, spring 2		
13- 5	257-81332-10	. PLATE, timing 1		
13- 6	207-81321-10	. CONTACT BREAKER ASS'Y 1		
13- 7	110-81347-20	. SCREW, pan head (4-12) 1		
13- 8	92901-04100	. WASHER, spring 1		
13- 9	92901-04200	. WASHER, plain 1		
13-10	207-81326-10	. CONDENSER 1		
13-11	110-81346-20	. SCREW, pan head (4-10) 1		
13-12	92901-04100	. WASHER, spring 1		
13-13	207-81331-10	. LUBRICATOR 1		
13-14	109-81328-10	. CLAMP, lead 1		
13-15	165-81145-21	. SCREW, pan head (4-8) 1		
13-16	92901-04100	. WASHER, spring 1		
13-17	98701-05015	SCREW, flat head 2		



CHASSIS

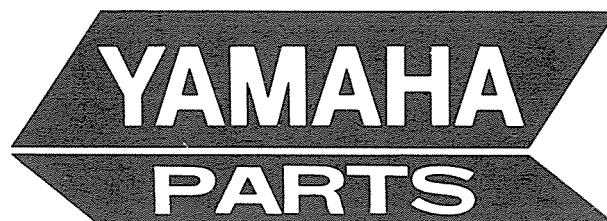
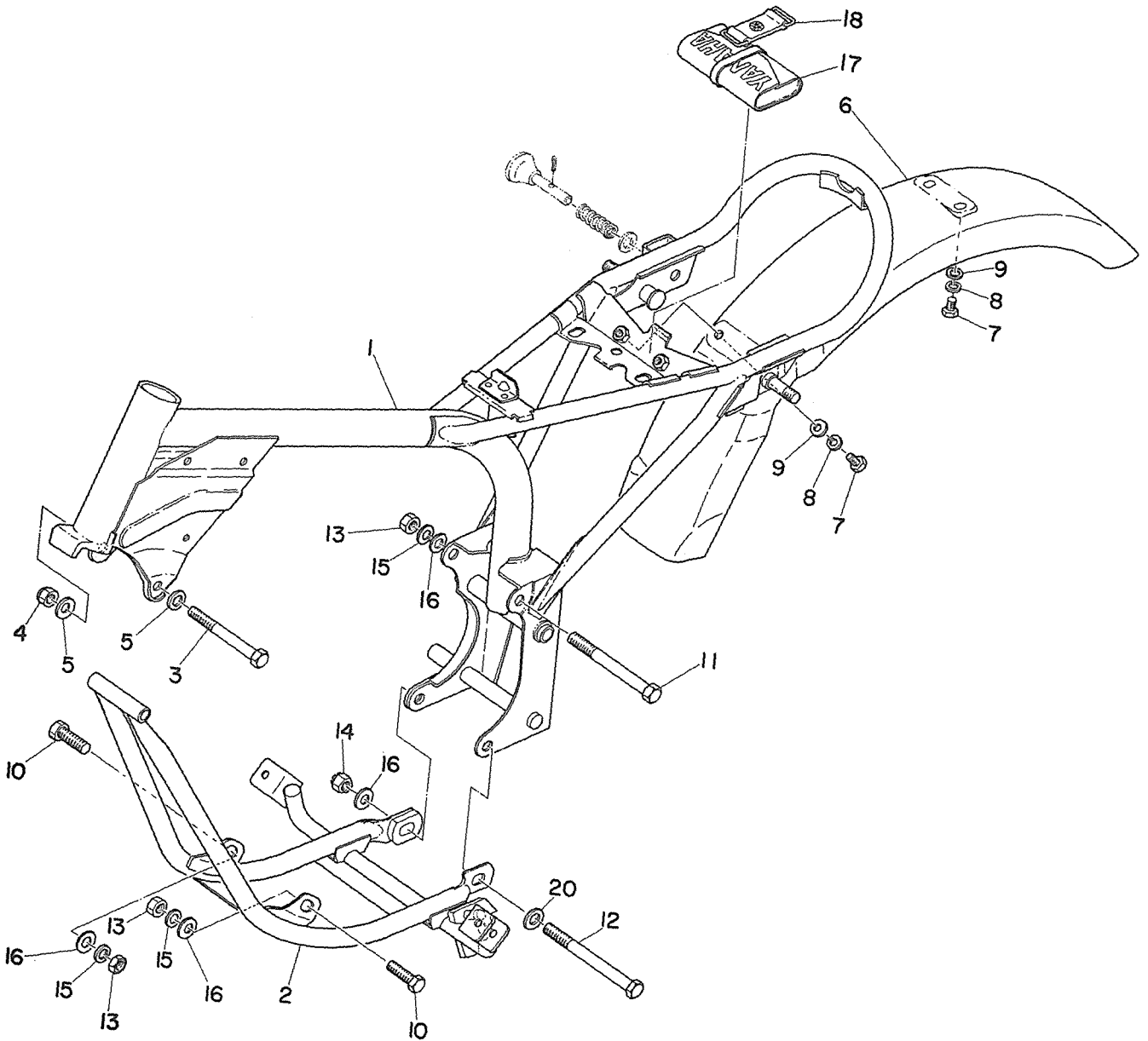





Fig. 14 FRAME



FRAME

Ref. No.	Part No.	Description	Q'ty	Applicable Machine No.	Remarks
14- 1	288-21110-00-33	FRAME COMP.	1		
14- 2	288-21280-00-33	DOWN TUBE COMP.	1		
14- 3	97201-08090	BOLT	1		
14- 4	183-22143-00	NUT	1		
14- 5	92901-08200	WASHER, plain	2		
14- 6	288-21610-00-74	REAR FENDER COMP.	1		Desert Orange
14- 7	91201-06010	BOLT	4		
14- 8	92901-06100	WASHER, spring	4		
14- 9	92901-06200	WASHER, plain	4		
14-10	97201-08030	BOLT	2		
14-11	97201-08100	BOLT	1		
14-12	97201-08115	BOLT	1		
14-13	98801-08100	NUT	3		
14-14	183-22143-00	NUT	1		
14-15	92901-08100	WASHER, spring	3		
14-16	92901-08200	WASHER, plain	4		
14-17	207-28100-00	TOOL ASS'Y	1		☆
14-18	288-21376-00	BAND, tool cover	1		

Fig. 15 REAR ARM & REAR CUSHION

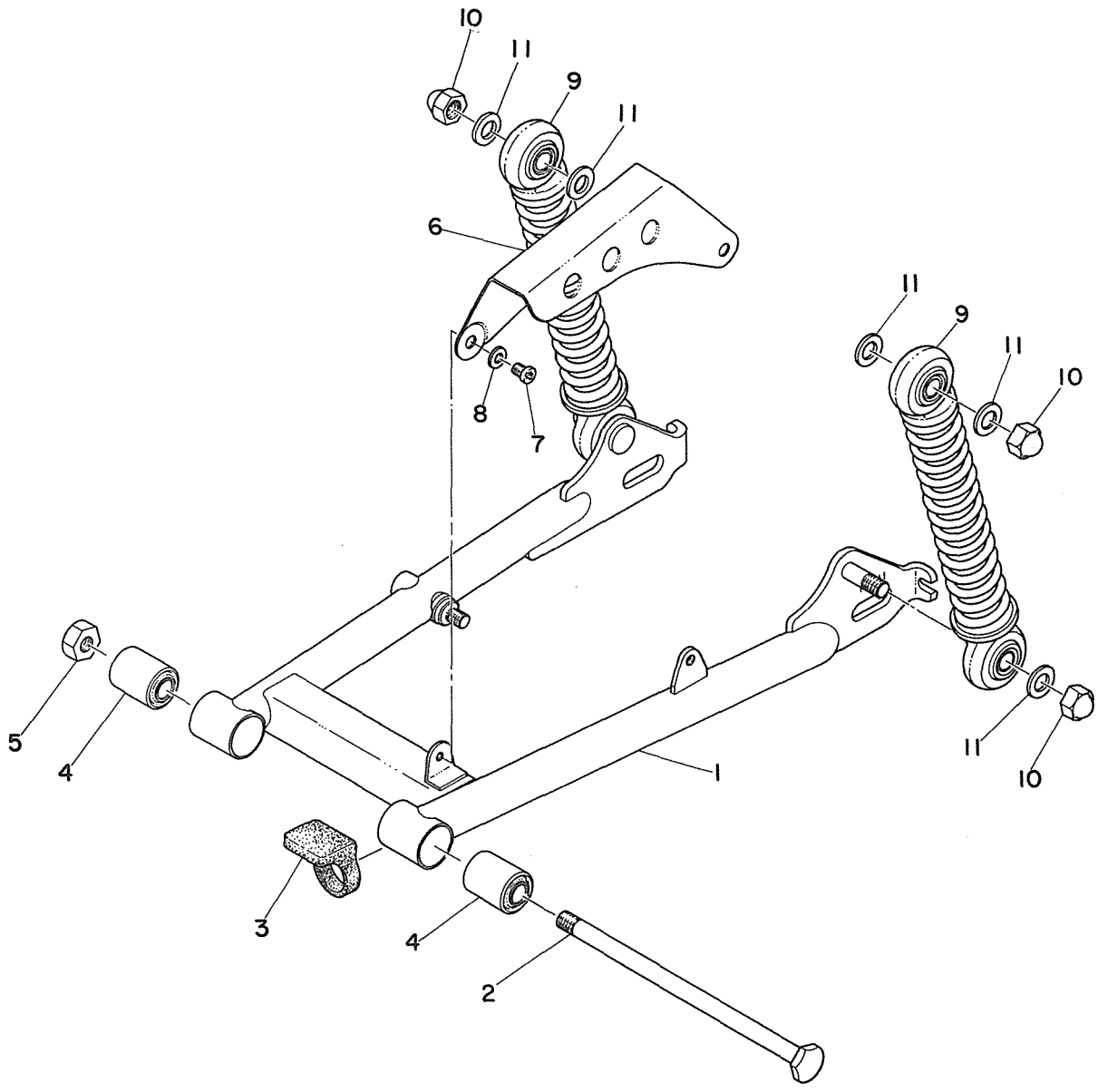

REAR ARM & REAR CUSHION

Ref. No.	Part No.	Description	Q'ty	Applicable Machine No.	Remarks
15- 1	288-22110-00-33	REAR ARM COMP.	1		
15- 2	288-22141-00	SHAFT, pivot	1		
15- 3	183-22151-00	SEAL, guard	1		
15- 4	102-22123-00	BUSHING, rear arm	2		
15- 5	92801-10100	NUT	1		
15- 6	288-22311-00-35	CHAIN CASE, half	1		
15- 7	98501-05008	SCREW, pan head	2		
15- 8	92901-05100	WASHER, spring	2		
15- 9	288-22210-00	REAR CUSHION ASS'Y	2		
15-10	9280 ⁴ 3 -10700	NUT, crown	4		
15-11	102-22243-00	WASHER, rear cushion (10-25-2) ..	6		

Fig. 16 STAND & BRAKE PEDAL

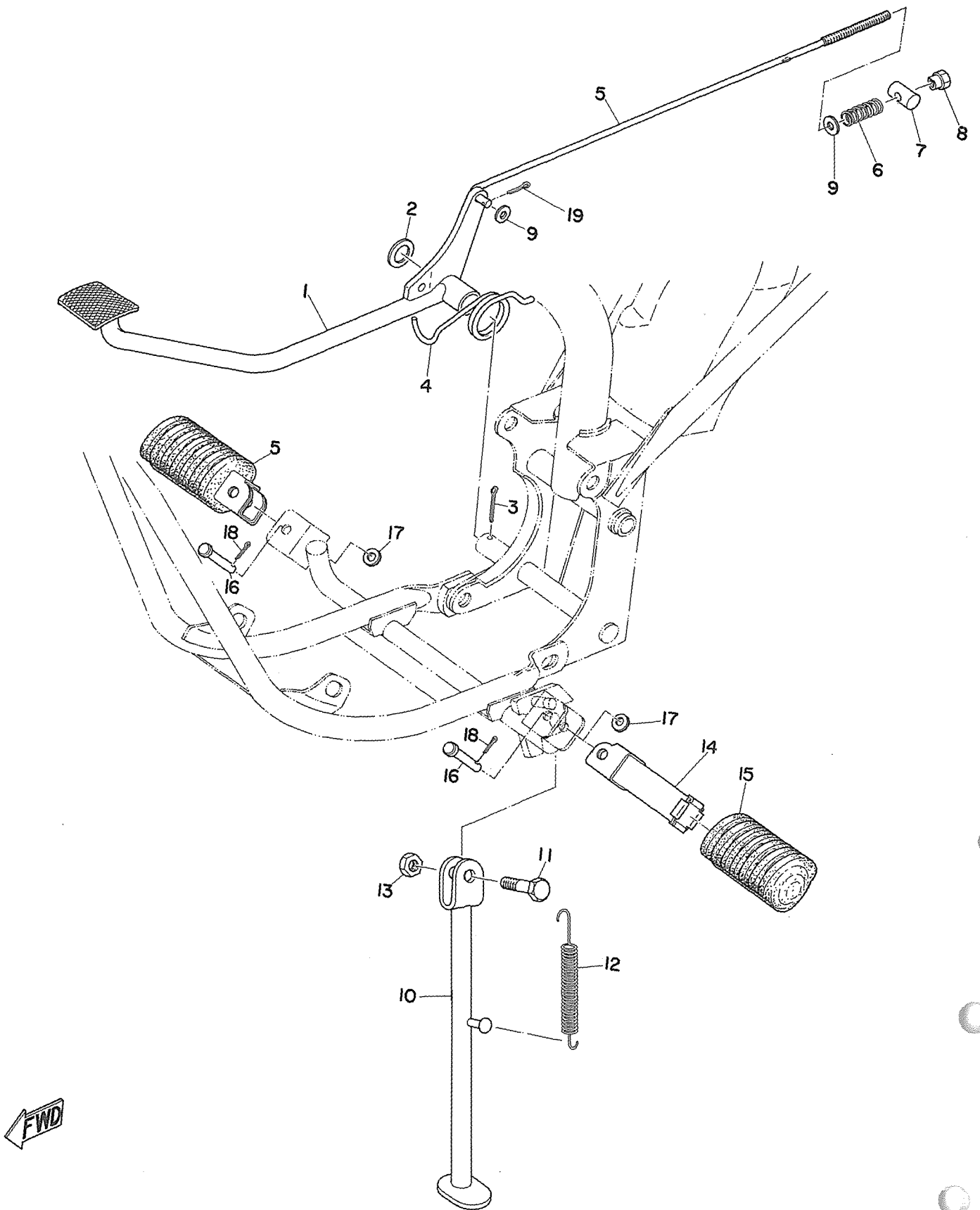

STAND & REAR BRAKE PEDAL

Ref. No.	Part No.	Description	Q'ty	Applicable Machine No.	Remarks
16- 1	288-27211-00-91	PEDAL, brake	1		
16- 2	135-22243-00	WASHER, rear cushion (14.8-27-2) .	1		
16- 3	91401-30020	PIN, cotter	1		
16- 4	183-27216-00	SPRING, return	1		
16- 5	288-27231-00	ROD, brake	1		
16- 6	180-27236-00	SPRING, rod	1		
16- 7	156-27237-00	PIN, clevis	1		
16- 8	282-27238-00	NUT, adjusting	1		
16- 9	92901-06200	WASHER, plain	2		
16-10	288-27311-00	STAND, side	1		
16-11	137-27317-00	BOLT, side stand	1		
16-12	150-27316-00	SPRING, side stand	1		
16-13	98801-08300	NUT	1		
16-14	214-27421-00	FOOTREST	2		
16-15	214-27413-00	COVER, footrest	2		
16-16	91501-08038	PIN, clevis	2		
16-17	156-27226-00	WASHER, pedal link (8.2-13-0.6) ..	2		
16-18	91401-20015	PIN, cotter	2		
16-19	91401-20012	PIN, cotter	1		

Fig. 17 FRONT FORK & FRONT FENDER

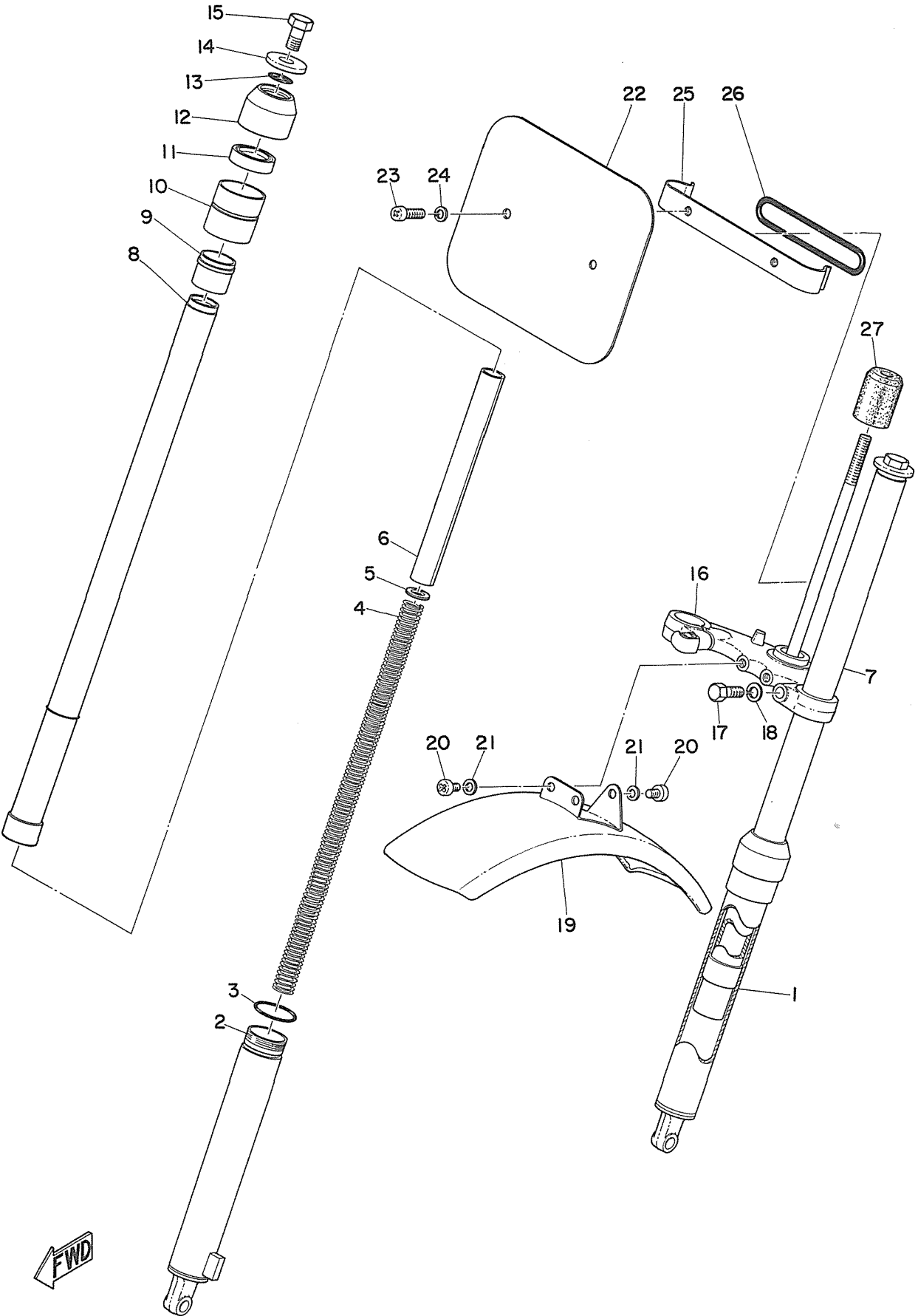

FWD

FRONT FORK & FRONT FENDER

Ref. No.	Part No.	Description	Q'ty	Applicable Machine No.	Remarks
17- 0-1	288-23100-00-74	FRONT FORK ASS'Y	1		Desert Orange
17- 1	288-23126-00-74	. TUBE, outer left	1		Desert Orange
17- 2	288-23136-00-74	. TUBE, outer right	1		Desert Orange
17- 3	207-23147-00	. O-RING	2		
17- 4	290-23141-00	. SPRING, fork	1		
17- 5	252-23149-00	. WASHER, spring upper	1		
					Only use the R.H.
17- 6	290-23118-00	. SPACER	1		
17- 7	290-23124-00	. TUBE, inner left	1		
17- 8	290-23134-00	. TUBE, inner right	1		
17- 9	109-23125-00	. METAL, slide	2		
17-10	290-23150-00	. OUTER NUT COMP.	2		
17-11	290-23145-00	. . OIL SEAL	2		
17-12	290-23144-00	. SEAL, dust	2		
17-13	122-23114-00	. PACKING	2		
17-14	207-23112-00	. WASHER, cap	2		
17-15	205-23111-40	. BOLT, cap	2		
17-16	290-23340-00	. UNDER BRACKET COMP.	1		
17-17	122-23346-00	. BOLT, under bracket	2		
17-18	92901-10100	. WASHER, spring	2		
17-19	288-21510-00-74	FRONT FENDER COMP.	1		Desert Orange
17-20	92501-06010	SCREW, pan head	3		
17-21	92901-06200	WASHER, plain	3		
17-22	288-23485-00	PLATE, number	1		
17-23	92501-06010	SCREW, pan head	2		

Fig. 17 FRONT FORK & FRONT FENDER

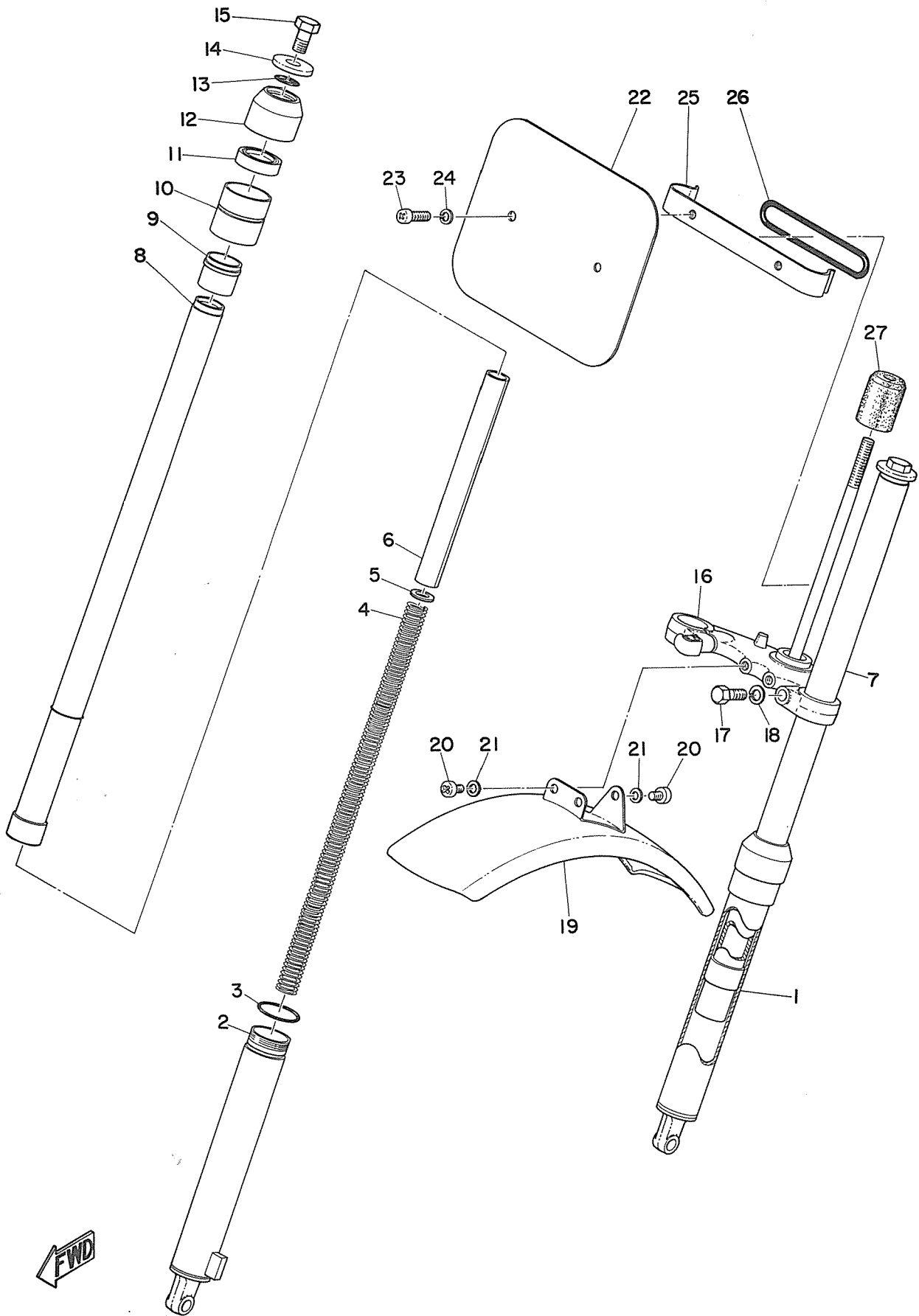

FRONT FORK & FRONT FENDER

Ref. No.	Part No.	Description	Q'ty	Applicable Machine No.	Remarks
17-24	92901-06200	WASHER, plain	2		
17-25	288-23486-00	STAY, plate	1		
17-26	288-23489-00	BAND	1		
17-27	288-23424-00	GUIDE, front fork	1		

Fig. 18 STEERING

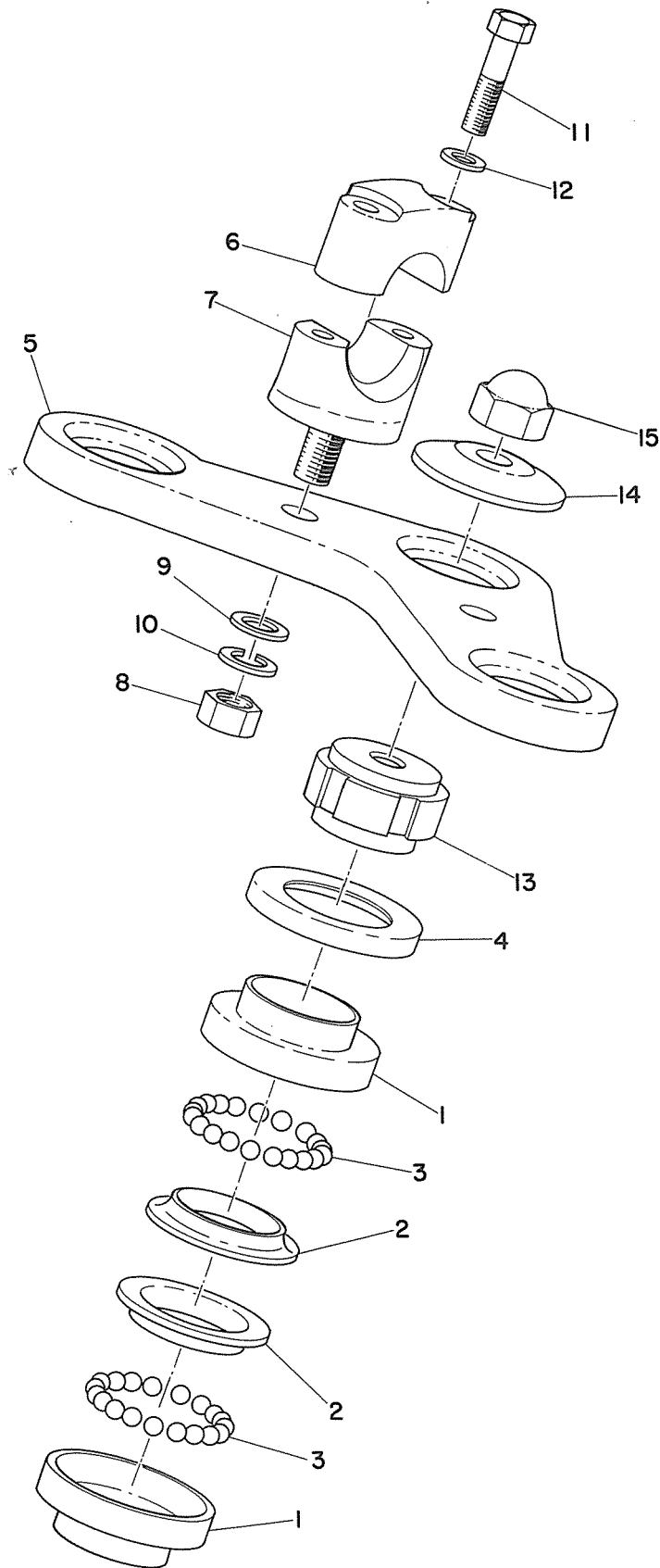

STEERING

Ref. No.	Part No.	Description	Q'ty	Applicable Machine No.	Remarks
18- 1	282-23412- 00 ⁰¹	RACE, ball 2	1	949 A	Qty need 2
18- 2	282-23414-00	RACE, ball 4	2		
18- 3	93503-16003	BALL (3/16 inch).....	48		
18- 4	288-23415-00	COVER, ball race	1		
18- 5	185-23435-00	CROWN, handle	1		
18- 6	122-23441-00	HOLDER, handle upper	2		
18- 7	122-23442-02	HOLDER, handle under	2		
18- 8	92801-10100	NUT	2		
18- 9	92901-10200	WASHER, plain	2		
18-10	92901-10100	WASHER, spring	2		
18-11	91101-06035	BOLT	4		
18-12	92901-06100	WASHER, spring	4		
18-13	288-23454-00	NUT, fitting	1		
18-14	122-23443-00	WASHER, crown	1		
18-15	92804-10700	NUT, crown	1		
18-16	282-23412	288-23413-00-00 Ball Race #3	1	949/A	E/N 26309

Fig. 19 HANDLE & WIRE

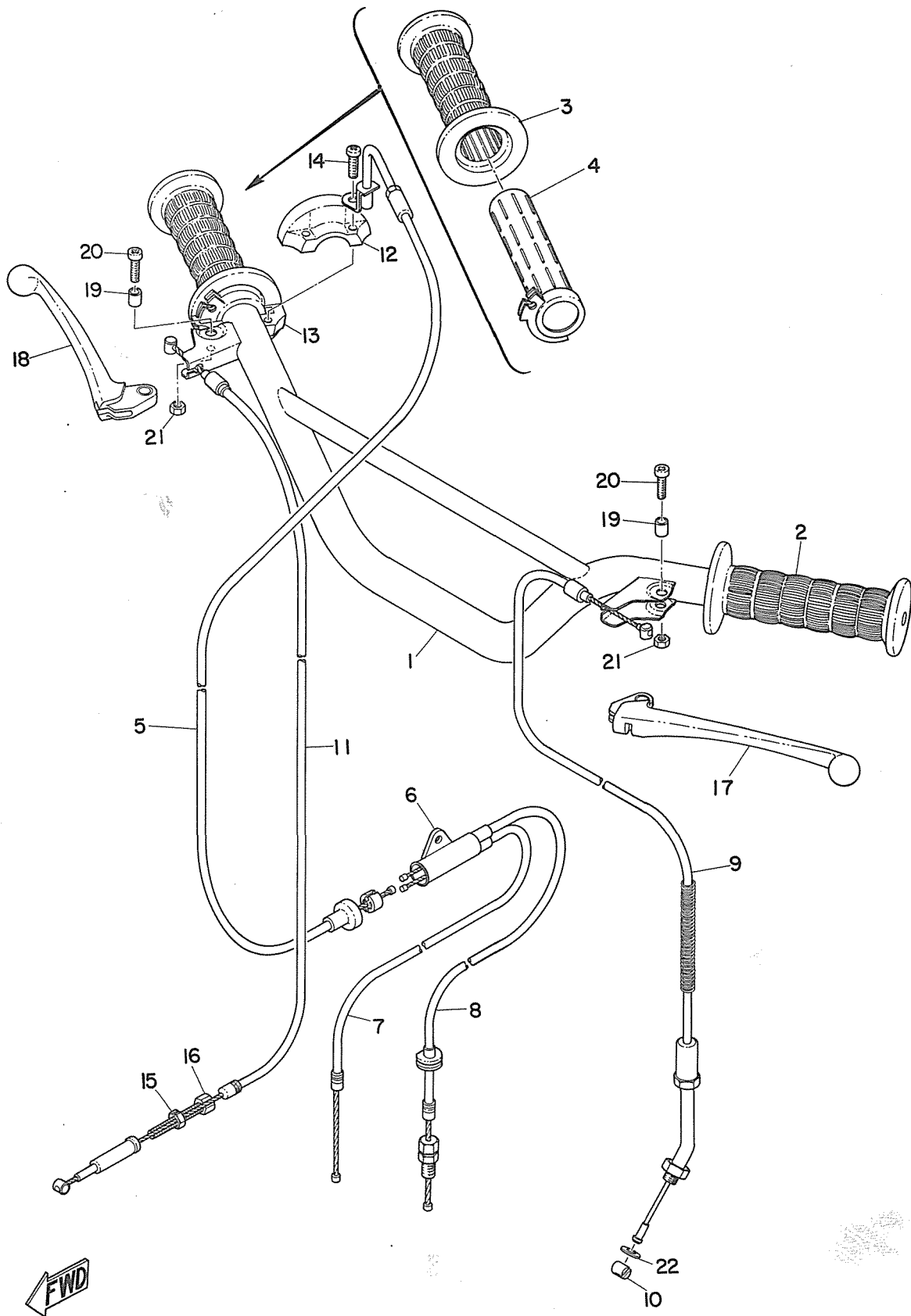

HANDLE & WIRE

Ref. No.	Part No.	Description	Q'ty	Applicable Machine No.	Remarks
19- 1	288-26111-00	HANDLE	1		
19- 2	214-26241-00	GRIP, left	1		
19- 3	214-26242-00	GRIP, right	1		
19- 4	214-26243-00	TUBE, guide	1		
19- 5	288-26311-00	WIRE, throttle 1	1		
19- 6	266-26261-00	CYLINDER	1		
19- 7	288-26312-00	WIRE, throttle 2	1		
19- 8	288-26321-00	WIRE, pump	1		
19- 9	288-26335-00	WIRE, clutch	1		
19-10	164-26363-00	. END, wire	1		
19-11	288-26341-00	WIRE, brake	1		
19-12	214-26281-01	CAP, grip upper	1		
19-13	248-26282-00	CAP, grip under	1		
19-14	98501-05018	SCREW, pan head	2		
19-15	109-26344-00	NUT, wire adjusting	1		
19-16	109-26345-00	BOLT, wire adjusting	1		
19-17	137-83912-01	LEVER, left <i>A-28</i>	1		
19-18	137-83922-01	LEVER, right <i>F-7</i>	1		
19-19	288-83913-00	COLLAR, lever	2		
19-20	98501-05018	SCREW, pan head	2		
19-21	98801-05100	NUT	2		
19-22	92901-06200	WASHER, plain	1		

Fig. 20 FUEL TANK

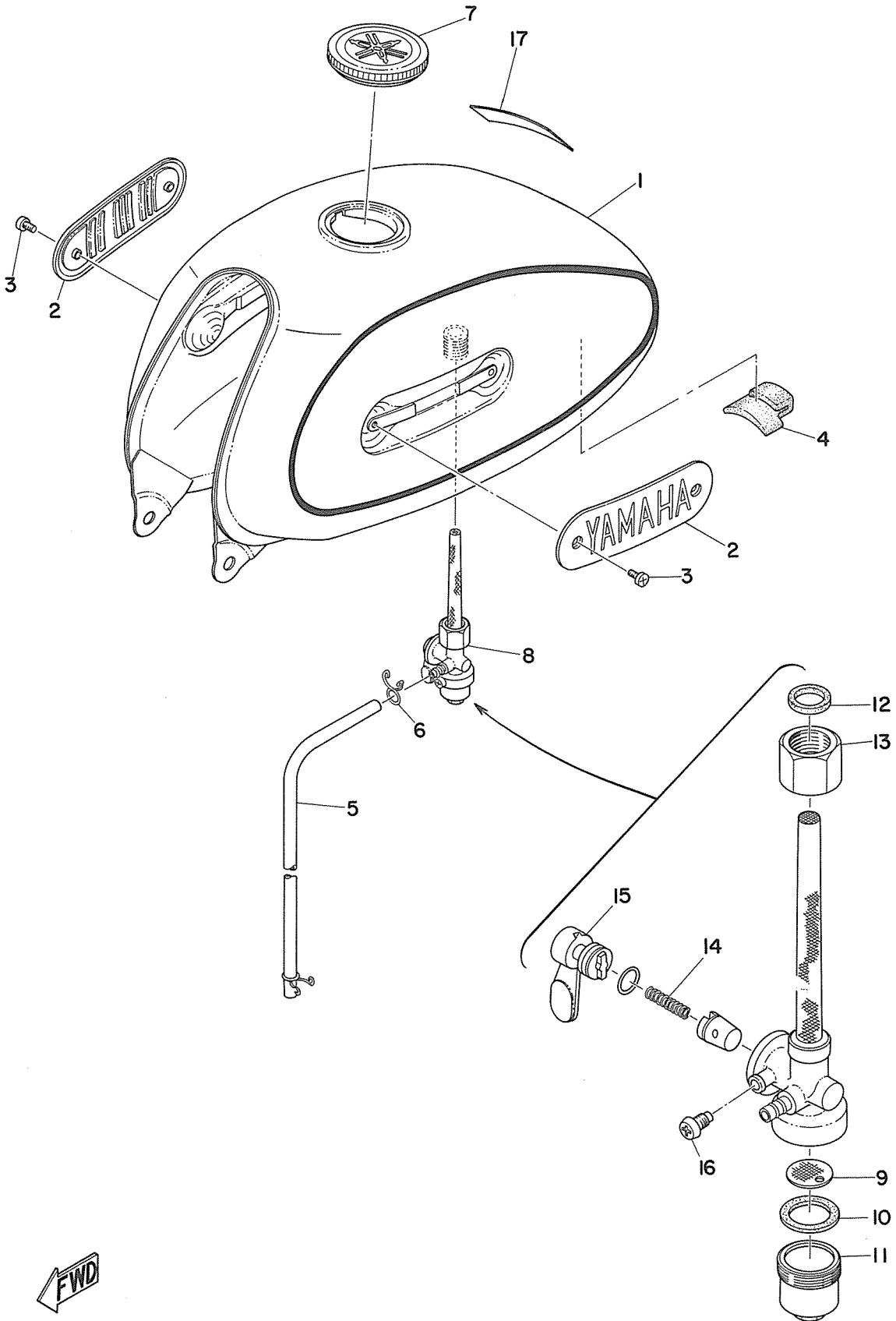

FUEL TANK

Ref. No.	Part No.	Description	Q'ty	Applicable Machine No.	Remarks
20- 1	288-24110-00-01	FUEL TANK COMP.	1		Desert Orange
20- 2	276-24161-00	EMBLEM	2		
20- 3	98501-04008	SCREW, pan head	4		
20- 4	288-24181-00	DAMPER, locating	1		
20- 5	626-24315-00	PIPE (5-235)	1		
20- 6	101-24356-00	CLIP, pipe	2		
20- 7	122-24610-01	CAP ASS'Y	1		
20- 8	127-24500-00	FUEL COCK ASS'Y	1		
20- 9	122-24515-00	. NET, filter	1		
20-10	102-24522-00	. GASKET, filter	1		
20-11	122-24521-00	. CUP, filter	1		
20-12	122-24532-00	. GASKET, nut	1		
20-13	122-24531-00	. NUT	1		
20-14	102-24529-00	. SPRING	1		
20-15	122-24524-00	. LEVER, cock	1		
20-16	127-24535-00	. SCREW, lever fitting	1		
20-17	288-21659-00	LAVEL, warning	1		

Fig. 21 OIL TANK

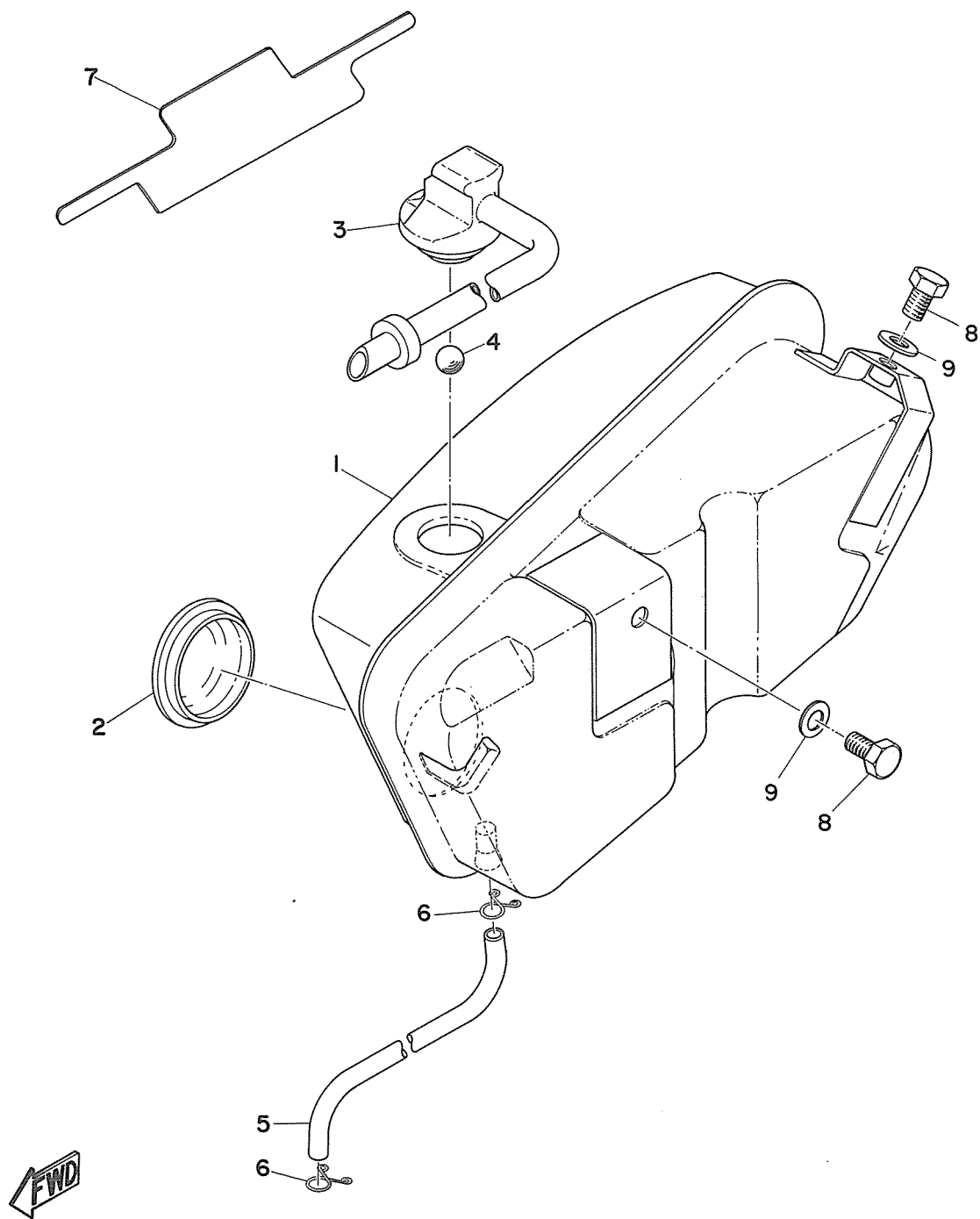

OIL TANK

Ref. No.	Part No.	Description	Q'ty	Applicable Machine No.	Remarks
21- 1	288-21705-00-74	OIL TANK ASS'Y	1		Desert Orange
21- 2	214-21761-00	. GAUGE, level	1		
21- 3	288-21771-00	BODY, cap	1		
21- 4	288-24684-00	BALL	1		
21- 5	132-24319-01	PIPE, oil (5-380)	1		
21- 6	101-24356-00	CLIP, oil	2		
21- 7	288-21787-00	EMBLEM, enduro	1		
21- 8	91201-06012	BOLT	2		
21- 9	92901-06200	WASHER, plain	2		

Fig. 22 SEAT

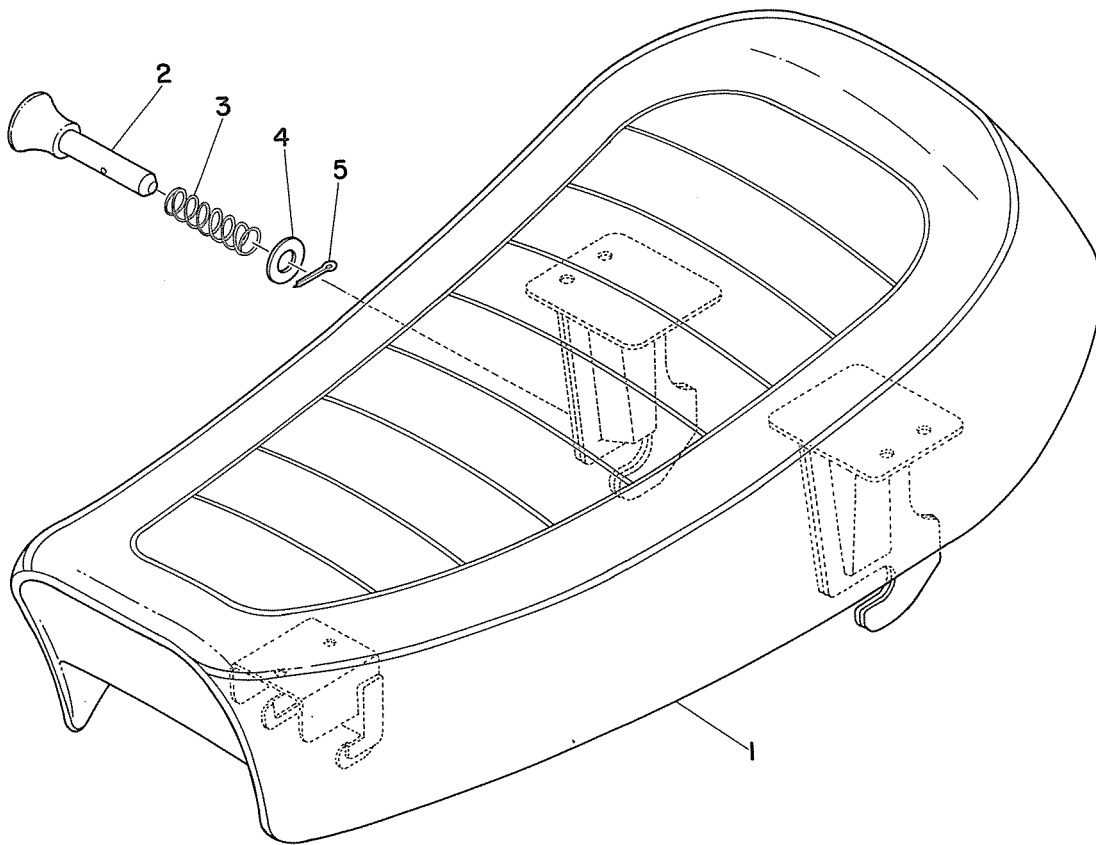

SEAT

Ref. No.	Part No.	Description	Q'ty	Applicable Machine No.	Remarks
22- 1	288-24770-00	SEMI-DOUBLE SEAT ASS'Y 1		
22- 1-1	288-24771-00	. COVER, seat 1		
22- 2	288-24727-00	PIN, seat fitting 1		
22- 3	288-24781-00	SPRING, seat 1		
22- 4	156-27226-00	WASHER (8.2-13-0.6) 1		
22- 5	91401-20012	PIN, cotter 1		

Fig. 23 FRONT WHEEL

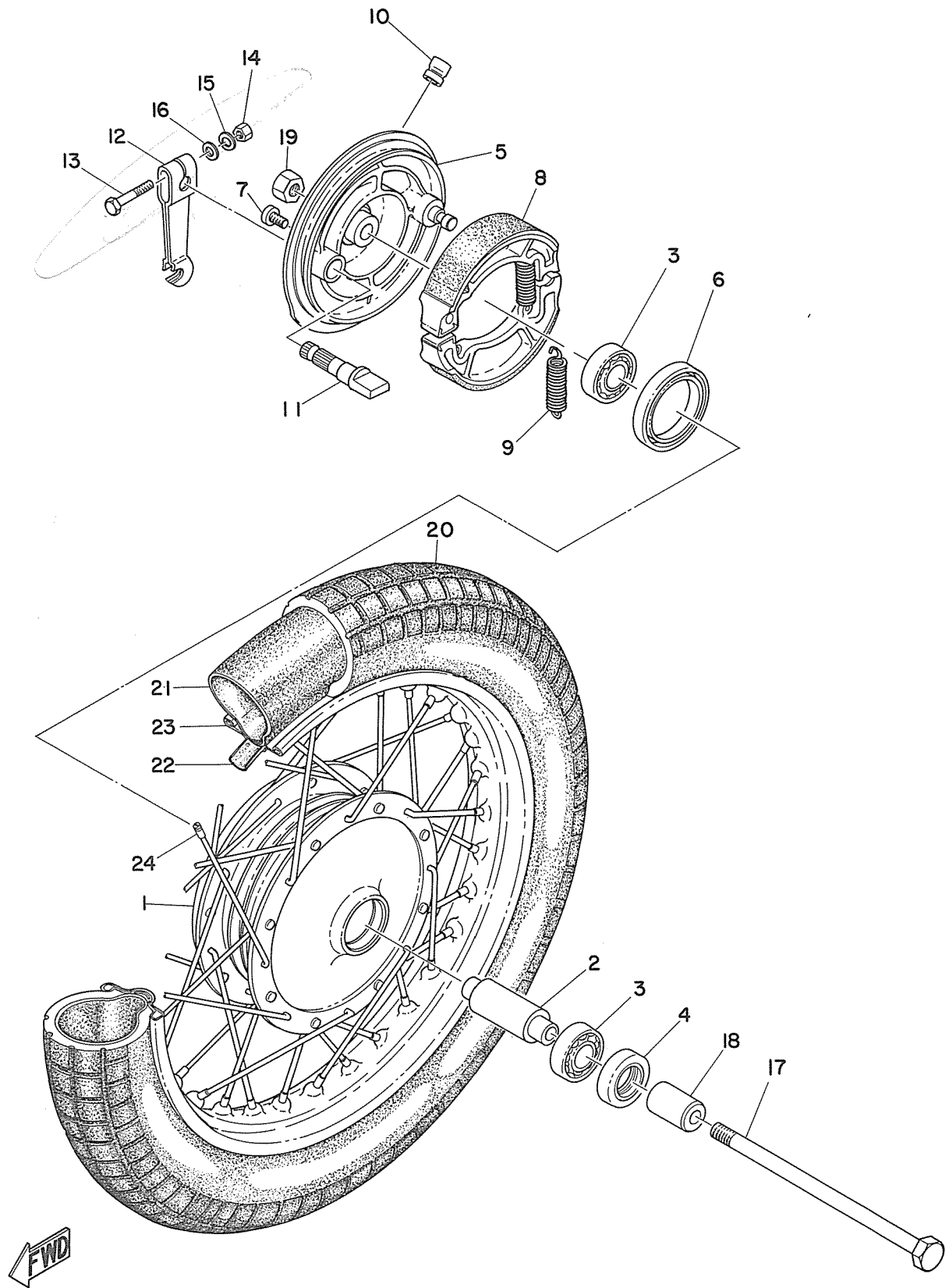

FRONT WHEEL

Ref. No.	Part No.	Description	Q'ty	Applicable Machine No.	Remarks
23- 1	288-25111-00	HUB, front	1		
23- 2	102-25117-00	SPACER, bearing	1		
23- 3	93306-20203	BEARING (6202)	2		
23- 4	93106-20001	OIL SEAL (DD20-35-7)	1		
23- 5	109-25121-01	PLATE, brake shoe	1		
23- 6	93107-42001	OIL SEAL (OS42-52.5-7)	1		
23- 7	92501-06010	SCREW, pan head	1		
23- 8	122-25330-00	BRAKE SHOE COMP.	2		
23- 9	102-25333-00	SPRING, return	2		
23-10	288-25139-00	PLUG, blind	1		
23-11	122-25351-01	CAM SHAFT	1		
23-12	109-25155-00	LEVER, cam shaft	1		
23-13	91201-06030 91183-06030	BOLT	1		
23-14	92801-06100	NUT	1		
23-15	92901-06100	WASHER, spring	1		
23-16	92901-06200	WASHER, plain	1		
23-17	128-25181-00	SHAFT, wheel	1		
23-18	128-25183-00	COLLAR, wheel shaft	1		
23-19	92801-10100	NUT	1		
23-20	94125-15091	TIRE (2.50-15-4PR)	1		☆
23-21	94225-15036	TUBE (2.50-15)	1		☆
23-22	94325-15028	BAND, rim (2.50-15)	1		
23-23	94414-15058	RIM (1.40-15)	1		
23-24	288-25104-00	SPOKE SET	1s		

Fig. 24 REAR WHEEL

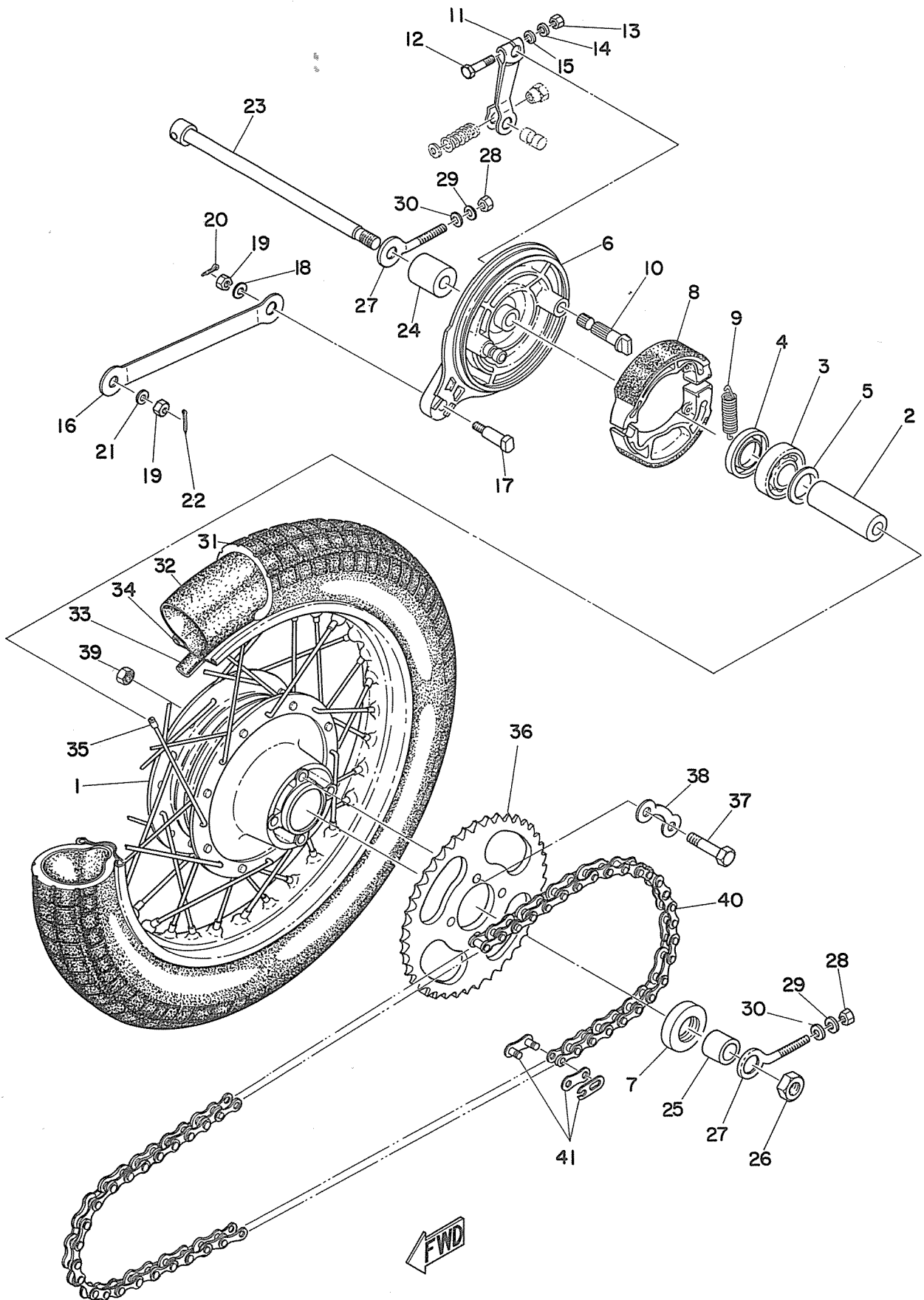

REAR WHEEL

Ref. No.	Part No.	Description	Q'ty	Applicable Machine No.	Remarks
24- 1	288-25311-00	HUB, rear	1		
24- 2	109-25317-00	SPACER, bearing	1		
24- 3	93306-30101	BEARING (6301)	1		
24- 4	93106-20002	OIL SEAL (DD-20-37-8)	1		
24- 5	102-25315-00	FLANGE, spacer	1		
24- 6	109-25321-02	PLATE, brake shoe	1		
24- 7	93102-18008	OIL SEAL (SD-18-37-8)	1		
24- 8	122-25330-00	BRAKE SHOE COMP.	2		
24- 9	102-25333-00	SPRING, return	2		
24-10	122-25351-01	CAM SHAFT	1		
24-10	122-25355-00	LEVER, cam shaft	1		
24-12	91201-06030	BOLT	1		
24-13	92801-06100	NUT	1		
24-14	92901-06100	WASHER, spring	1		
24-15	92901-06200	WASHER, plain	1		
24-16	102-25371-00	BAR, tension	1		
24-17	109-25373-00	BOLT, tension bar	1		
24-18	92901-08100	WASHER, spring	1		
24-19	98801-08300	NUT	2		
24-20	91401-20012	PIN, cotter	1		
24-21	92901-08200	WASHER, plain	1		
24-22	91401-20012	PIN, cotter	1		
24-23	288-25381-00	SHAFT, wheel	1		
24-24	102-25383-00	COLLAR, wheel shaft	1		

Fig. 24 REAR WHEEL

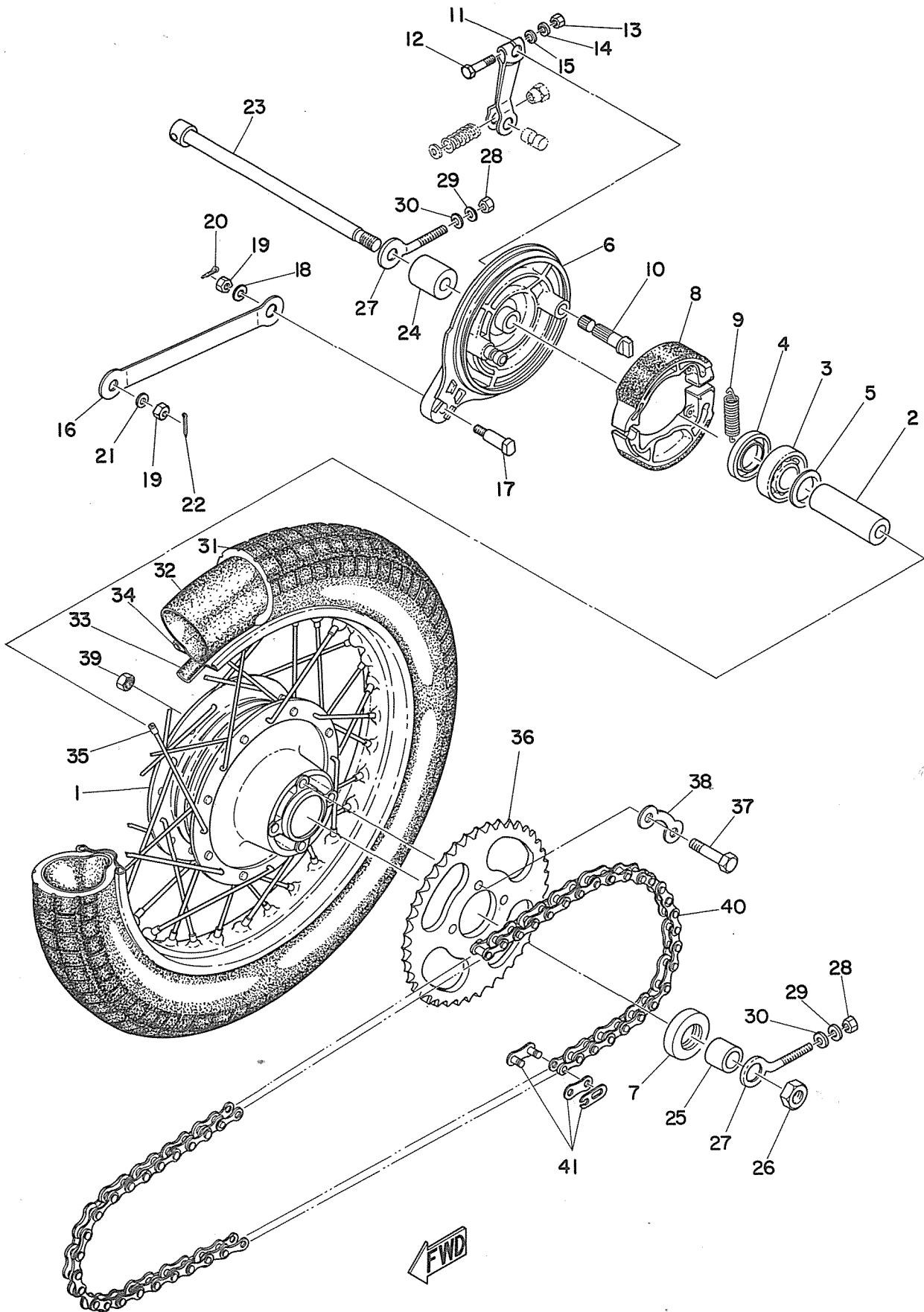

REAR WHEEL

Ref. No.	Part No.	Description	Q'ty	Applicable Machine No.	Remarks
24-25	109-25377-01	COLLAR, shaft	1		
24-26	183-25182-00	NUT, shaft	1		
24-27	102-25389-00	PULLER, chain	2		
24-28	92801-06100	NUT	2		
24-29	92901-06100	WASHER, spring	2		
24-30	92901-06200	WASHER, plain	2		
24-31	94125-15091	TIRE (2.50-15-4PR)	1		☆
24-32	94225-15036	TUBE (2.50-15)	1		☆
24-33	94325-15028	BAND, rim (2.50-15)	1		
24-34	94414-15058	RIM (1.40-15)	1		
24-35	288-25304-00	SPOKE SET	1s		
24-36	288-25441-10	GEAR, sprocket wheel (41T)	1		
24-37	109-25411-00	BOLT, fitting	4		
24-38	101-25412-00	WASHER, lock	2		
24-39	98801-08300	NUT	4		
24-40	94504-20090	CHAIN (DK420-90L)	1		
24-41	94604-20001	JOINT, chain	1		

Fig. 25 ELECTRICAL

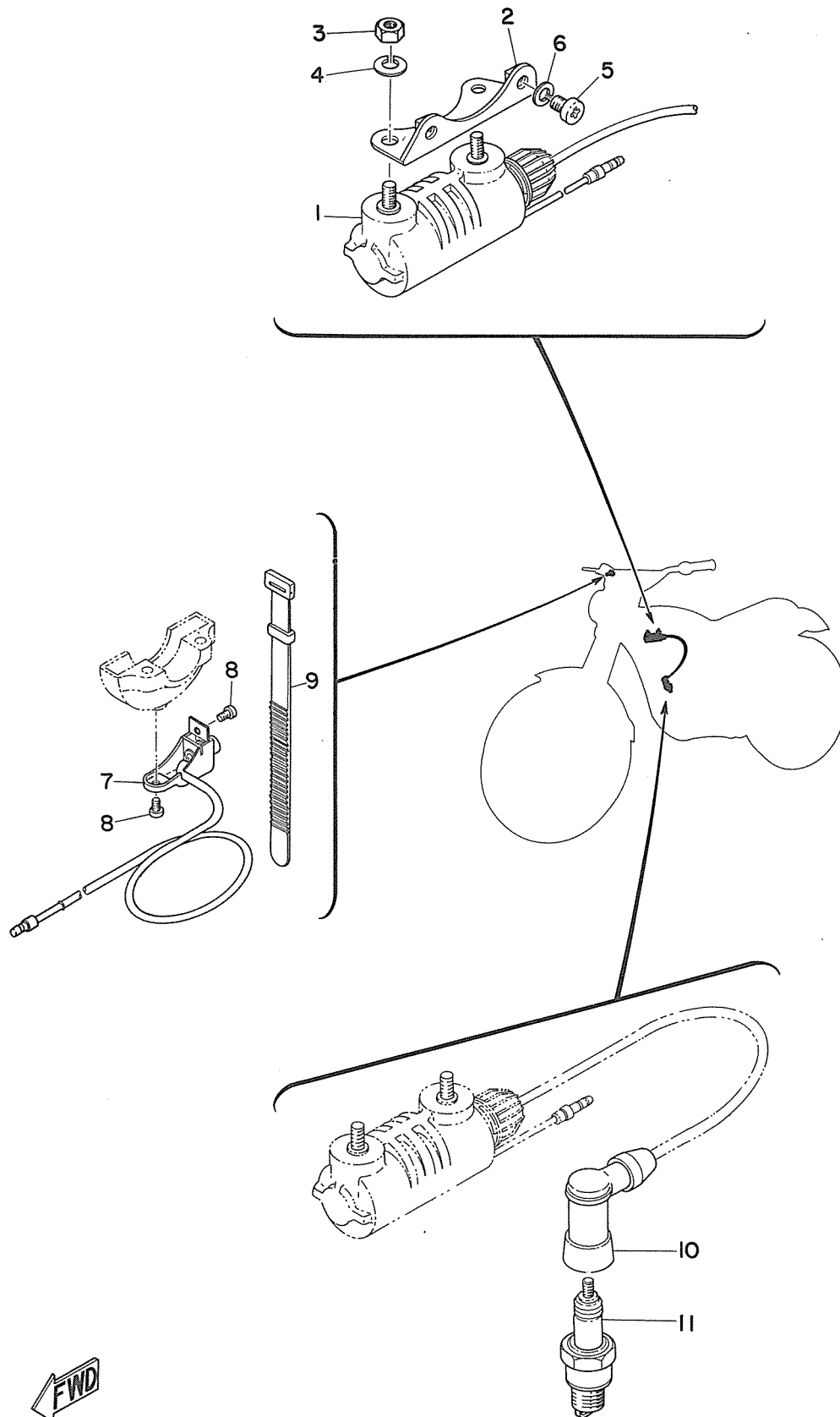

ELECTRICAL

Ref. No.	Part No.	Description	Q'ty	Applicable Machine No.	Remarks
25- 1	248-82310- ¹¹ 10	IGNITION COIL ASS'Y	1		
25- 2	248-82316-00	BRACKET, ignition coil	1		
25- 3	92801-06100	NUT ,.....	2		
25- 4	92901-06100	WASHER, spring	2		
25- 5	92501-06012	SCREW, pan head	2		
25- 6	92901-06100	WASHER, spring	2		
25- 7	261-83976-00	SWITCH, handle 1	1		
25- 8	98501-05005	SCREW, pan head	2		
25- 9	168-83936-01	BAND, switch cord	1		
25-10	117-82370-20	PLUG CAP ASS'Y	1		
25-11	94700-00040	PLUG, spark (B-7HS)	1		



MOTORCYCLE PARTS NEWS

NUMBER
304

PAGE
1

YAMAHA INTERNATIONAL CORPORATION
MONTEBELLO, CALIFORNIA

DATE 1/27/71

JT1 LIGHTING KIT (P/N ACC-01100-04-00)

As mentioned in Service News Bulletin #261 the following lighting kit is available for the JT1.

THE KIT DOES NOT MAKE THE JT1 LEGAL FOR STREET USE AND IS OFFERED AS AN ACCESSORY ONLY TO MAKE THE MACHINE MORE USEABLE FOR THE DIRT RIDER.

<u>PART NUMBER</u>	<u>DESCRIPTION</u>	<u>Q'TY</u>	<u>PRICE</u>	<u>DISCOUNT</u>
ACC-01100-04-00	JT1 Lighting Kit (comp)	1	\$17.50	N/D
288-84110-60-00	.Headlamp Unit Assy	1		
241-84330-00-74	.Body	1		
173-84313-00-00	.Wire, earth	1		
195-84325-00-00	.Screw	1		
290-84118-00-00	.Stay, headlamp	1		
290-84119-00-00	.Stay, headlamp	1		
912-01060-15-00	.Bolt	2		
929-01062-00-00	.Washer	2		
972-04080-20-00	.Bolt	2		
929-03082-00-00	.Washer	2		
929-01081-00-00	.Washer	2		
988-01081-00-00	.Nut	2		
288-84510-60-00	.Taillamp Unit Assy	1		
288-84551-09-00	.Bracket	1		
152-84518-00-00	.Grommet	2		
912-01060-12-00	.Bolt	3		
988-01061-00-00	.Nut	3		
922-01061-00-00	.Washer	3		
290-82530-00-00	.Stop Switch	1		
290-82539-00-00	.Stay, Switch	1		
288-83973-00-00	.Switch, Handle	1		
214-83974-00-00	.Holder, Switch	1		
985-03050-18-00	.Screw	1		
288-81313-10-00	.Coil, Lighting	1		
288-82590-20-00	.Wire, Harness	1		
803-82591-00-00	.Clamp, Wiring	1		

TOTAL PIECES: 39

NOTE: Suggested retail price for the above unit is: \$25.95.
Installation will require approximately 2 hours.

Available: Feb. 10 @ Bellmawr
Mar. 1 @ Los Angeles

PLEASE MAKE NOTE OF THIS BULLETIN IN YOUR JT1 PARTS BOOK

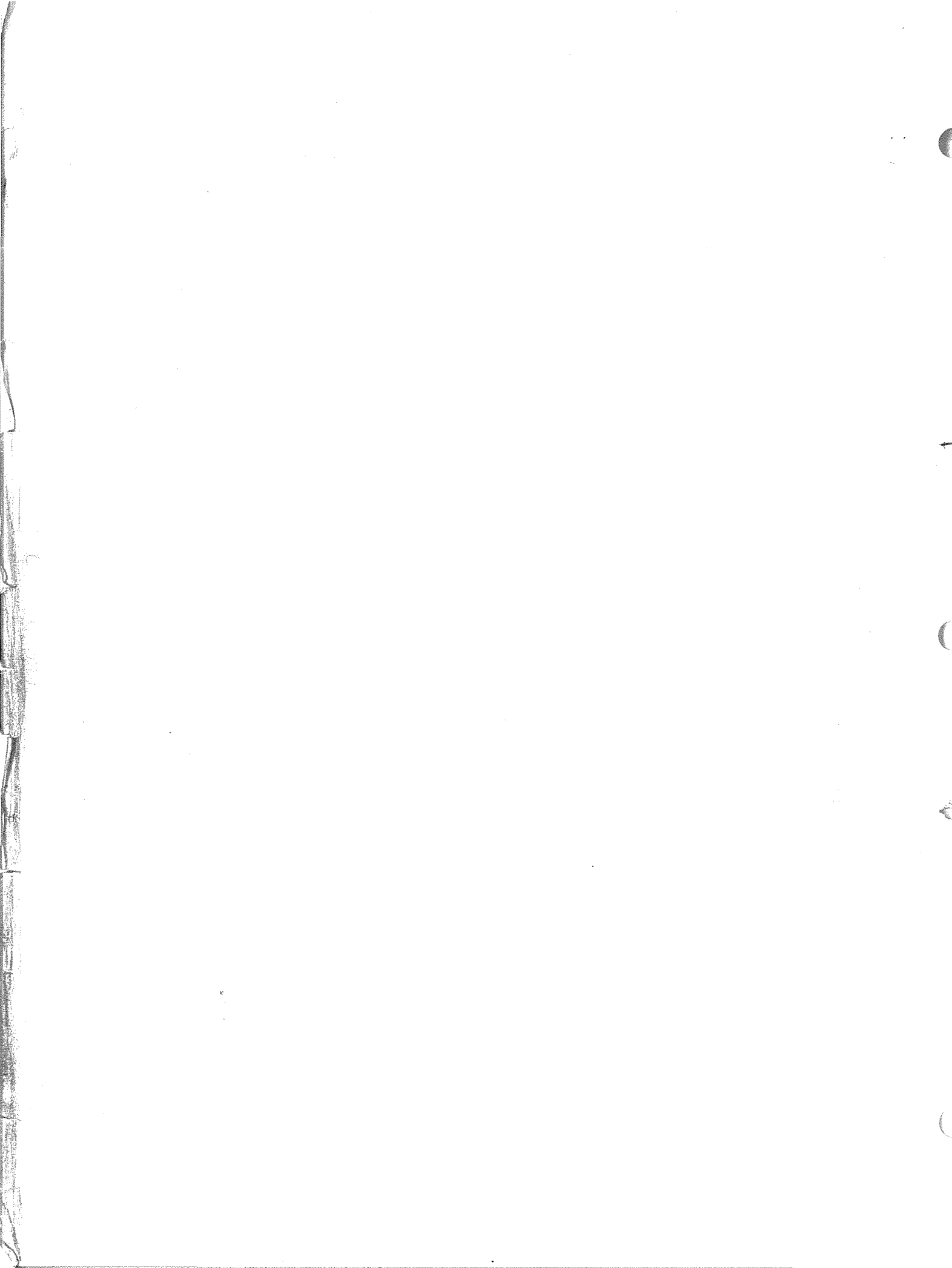

NUMERICAL INDEX

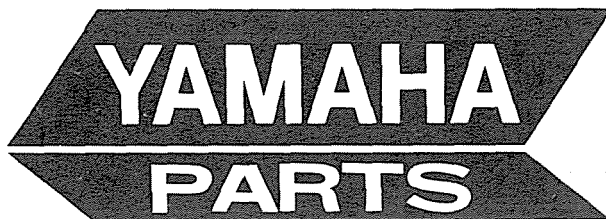



NUMERICAL INDEX

Ref No.	Parts No.	Ref No.	Parts No.	Ref No.	Parts No.
12- 7	101-18137-00	25-10	117-82370-20	8-13	132-15664-00
20- 6	101-24356-00	2-16	122-15486-00	8-12	132-15665-00
21- 6	101-24356-00	8- 2	122-15612-01	8-11	132-15676-00
24-38	101-25412-00	4- 2	122-16164-00	2- 3	132-16346-00
3- 8	102-11633-01	4-13	122-16164-00	7-10	132-18113-01
15- 4	102-22123-00	17-13	122-23114-00	7- 2	132-18123-00
15-11	102-22243-00	17-17	122-23346-00	7- 3	132-18124-00
20-10	102-24522-00	18- 6	122-23441-00	7- 4	132-18133-00
20-14	102-24529-00	18- 7	122-23442-02	7- 7	132-18137-00
23- 2	102-25117-00	18-14	122-23443-00	6-17	132-18140-00
24- 5	102-25315-00	20- 9	122-24515-00	6-19	132-18143-00
23- 9	102-25333-00	20-11	122-24521-00	6-18	132-18177-00
24- 9	102-25333-00	20-15	122-24524-00	21- 5	132-24319-01
24-10	102-25371-00	20-13	122-24531-00	16- 2	135-22243-00
24-24	102-25383-00	20-12	122-24532-00	11- 5	136-22316-00
24-27	102-25389-00	20- 7	122-24610-01	1-27	136-82543-00
1-13	107-11181-01	23- 8	122-25330-00	12-15	137-13128-00
1-11	109-11351-00	24- 8	122-25330-00	12-10	137-13137-00
1-10	109-11361-00	23-11	122-25351-01	12-11	137-13138-01
17- 9	109-23125-00	24-10	122-25351-01	12-20	137-13165-00
23- 5	109-25121-01	24-10	122-25355-00	12-26	137-13165-00
23-12	109-25155-00	1-15	126-11171-60	12-19	137-13167-00
24- 2	109-25317-00	3- 3	126-11651-00	12-27	137-13167-00
24- 6	109-25321-02	12- 1	126-13116-00	12-18	137-13169-00
24-17	109-25373-00	20- 8	127-24500-00	12- 4	137-13176-00
24-25	109-25377-01	20-16	127-24535-00	12-22	137-13187-00
24-37	109-25411-00	23-17	128-25181-00	5-20	137-15643-00
19-15	109-26344-00	23-18	128-25183-00	4- 7	137-16333-00
19-16	109-26345-00	4- 5	131-16321-00	4- 8	137-16337-01
13-14	109-81328-10	3- 9	132-11634-00	4- 9	137-16356-00
13-11	110-81346-20	11-10	132-14613-00	3-19	137-16377-00
13- 7	110-81347-20	1-17	132-15351-00	4-10	137-16377-00
13- 3	110-81348-20	1-18	132-15353-00	4-11	137-16378-00
3-10	113-11601-02	8- 4	132-15616-00	16-11	137-27317-00
3-10	113-11601-12	8- 5	132-15617-00	19-17	137-83912-01
3-10	113-11601-22	5-22	132-15653-00-10	19-18	137-83922-01
4-23	116-16153-00	5-22	132-15653-00-12	3-25	146-11545-00
8-15	117-15644-00	5-22	132-15653-00-14	6- 7	150-18328-00

NUMERICAL INDEX

Ref No.	Parts No.	Ref No.	Parts No.	Ref No.	Parts No.
16-12	150-27316-00	12-25	214-13164-00	2-18	257-15463-00
8- 6	156-15618-01	11- 9	214-14766-00	5-21	257-15651-00
16-17	156-27226-00	8- 3	214-15625-00	8-18	257-15668-00
22- 4	156-27226-00	21- 2	214-21761-00	3-17	257-16111-00
16- 7	156-27237-00	19- 2	214-26241-00	3-15	257-16136-00
2- 6	164-15415-00	19- 3	214-26242-00	4- 1	257-16150-01
4-22	164-15631-01	19- 4	214-26243-00	4-12	257-16181-00
3-18	164-16119-00	19-12	214-26281-01	4- 0-1	257-16301-01
6-13	164-18561-00	16-15	214-27413-00	4- 4	257-16324-00
19-10	164-26363-00	16-14	214-27421-00	4-19	257-16341-00
13-15	165-81145-21	7- 9	248-18111-00-93	4-16	257-16342-00
25- 9	168-83936-01	19-13	248-26282-00	4-21	257-16343-00
6-11	174-18544-00	25- 1	248-82310-10	2- 2	257-16345-00
11- 8	178-14766-00	25- 2	248-82316-00	4- 6	257-16351-00
1-20	180-13554-00	17- 5	252-23149-00	4-15	257-16357-00
2-15	180-15362-00	17- 6	290-23118-00	4- 3	257-16371-00
8-16	180-15641-00	17- 7	290-23124-00	5- 4	257-17121-00
8- 8	180-15660-00	17- 4	290-23141-00	5- 2	257-17131-01
8-17	180-15687-00	17-12	290-23144-00	5- 5	257-17141-00
16- 6	180-27236-00	17-10	290-23150-00	5-16	257-17211-01
14- 4	183-22143-00	17-16	290-23340-00	5-17	257-17219-00-06
14-14	183-22143-00	3- 5	257-11681-00	5-13	257-17221-01
15- 3	183-22151-00	12- 0-1	257-13101-00	5-15	257-17231-00
24-26	183-25182-00	12-24	257-13161-00	5-11	257-17241-00
16- 4	183-27216-00	12- 2	257-13175-00	5-12	257-17258-00
18- 5	185-23435-00	12- 6	257-13178-00	5- 1	257-17411-01
5-19	201-15653-00	3-13	257-13512-00	5- 3	257-17414-00
17-15	205-23111-40	3-14	257-13515-00	5-14	257-17414-00
17-14	207-23112-00	1-21	257-13551-00	5-27	257-17461-20
17- 3	207-23147-00	1- 1	257-15111-00	5-27	257-17461-30
14-17	207-28100-00	1- 2	257-15121-00	5-27	257-17461-40
13- 2	207-81312-10	5-30	257-15389-00	5-27	257-17461-50
13- 6	207-81321-10	2- 1	257-15410-00	5-26	257-17462-00
13-10	207-81326-10	2-17	257-15413-00	5-29	257-17463-00
13-13	207-81331-10	2- 5	257-15417-01	5-28	257-17464-00
13- 1	207-81350-10	2-10	257-15421-00	5- 8	257-17471-00
3-22	214-11557-01	2-21	257-15433-00	7- 1	257-18101-00
12-23	214-13162-00	2-11	257-15451-00	6- 3	257-18512-00

NUMERICAL INDEX

Ref No.	Parts No.	Ref No.	Parts No.	Ref No.	Parts No.
6-20	257-18531-00	10- 2	288-14341-00	17- 1	288-23126-00-74
6- 1	257-18534-00	10- 1	288-14342-38	17- 2	288-23136-00-74
6- 8	257-18541-60	10- 3	288-14343-42	18- 4	288-23415-00
6- 4	257-18552-00	10- 3	288-14343-43	17-27	288-23424-00
6-16	257-18589-00	10- 3	288-14343-44	18-13	288-23454-00
13- 5	257-81332-10	10- 4	288-14344-25	17-22	288-23485-00
1-14	259-11111-01-74	10-17	288-14371-00	17-25	288-23486-00
1-12	259-11311-00	10-30	288-14379-00	17-26	288-23489-00
3- 0-1	259-11400-00	10- 7	288-14381-00	20- 1	288-24110-00-74
3- 1	259-11412-00	10- 6	288-14384-00	20- 4	288-24181-00
3- 2	259-11422-00	10- 5	288-14385-00	21- 4	288-24684-00
6- 2	259-18511-00	10-13	288-14390-10	22- 2	288-24727-00
25- 7	261-83967-00	9- 1	288-14411-00	22- 1	288-24770-00
19- 6	266-26261-00	9- 2	288-14412-00	22- 1-1	288-24771-00
8- 0-1	276-15610-00-93	9- 3	288-14451-00	22- 3	288-24781-00
8- 1	276-15611-00	9- 4	288-14453-00	23-24	288-25104-00
20- 2	276-24161-00	2-20	288-14481-00	23- 1	288-25111-00
18- 1	282-23412-00	11- 1	288-14610-30	23-10	288-25139-00
18- 2	282-23414-00	11-14	288-14623-00	24-35	288-25304-00
16- 8	282-27238-00	11- 6	288-14718-30	24- 1	288-25311-00
10-31	288-14118-00	11- 2	288-14752-30	24-23	288-25381-00
10-27	288-14124-00	1-19	288-15371-00	24-36	288-25441-10
10-10	288-14125-00	1-20	288-15373-00	19- 1	288-26111-00
10-20	288-14136-00	1-27	288-18588-00	19- 5	288-26311-00
10-19	288-14137-00	14- 1	288-21110-00-33	19- 7	288-26312-00
10-22	288-14158-00	14- 2	288-21280-00-33	19- 8	288-26321-00
10-26	288-14161-00	14-18	288-21376-00	19- 9	288-26335-00
10-33	288-14197-00	17-19	288-21510-00-74	19-11	288-26341-00
10- 0-1	288-14301-00	14- 6	288-21610-00-74	16- 1	288-27211-00-91
10-14	288-14312-15	20-17	288-21659-00	16- 5	288-27231-00
10-15	288-14314-00	21- 1	288-21705-00-74	16-10	288-27311-00
10-24	288-14321-00	21- 3	288-21771-00	13- 0-1	288-81300-10
10-12	288-14323-00	21- 7	288-21787-00	19-19	288-83913-00
10-21	288-14331-00	15- 1	288-22110-00-33	3- 7	289-11631-00-96
10-23	288-14333-00	15- 2	288-22141-00	3- 7	289-11631-00-97
10-11	288-14334-00	15- 9	288-22210-00	3- 7	289-11631-00-98
10-18	288-14335-00	15- 6	288-22311-00-35	3- 7	289-11631-00-99
10-16	288-14336-00	17- 0-1	288-23100-00-74	3- 7	289-11635-00

NUMERICAL INDEX

Ref No.	Parts No.	Ref No.	Parts No.	Ref No.	Parts No.
3- 7	289-11636-00	1- 5	92501-06045	17-24	92901-06200
17- 8	290-23134-00	2- 8	92501-06045	19-22	92901-06200
17-11	290-23145-00	1- 6	92501-06050	21- 9	92901-06200
20- 5	626-24315-00	1- 9	92501-06055	23-16	92901-06200
8- 7	91101-06020	1- 7	92501-06060	24-15	92901-06200
18-11	91101-06035	1- 8	92501-06065	24-30	92901-06200
14- 7	91201-06010	23-14	92801-06100	11-12	92901-08100
21- 8	91201-06012	24-13	92801-06100	14-15	92901-08100
11- 3	91201-06015	24-28	92801-06100	24-18	92901-08100
7-11	91201-06020	25- 3	92801-06100	11-13	92901-08200
23-13	91201-06030	4-20	92801-06300	14- 5	92901-08200
24-12	91201-06030	15- 5	92801-10100	14-16	92901-08200
10-25	91401-12010	18- 8	92801-10100	24-21	92901-08200
12-16	91401-12018	23-19	92801-10100	17-18	92901-10100
10-32	91401-16012	15-10	92803-10700	18-10	92901-10100
19-19	91401-20012	18-15	92804-10700	18- 9	92901-10200
22- 5	91401-20012	10- 8	92901-04100	3-23	92901-12100
24-20	91401-20012	10-28	92901-04100	12- 5	93101-10001
24-22	91401-20012	13- 4	92901-04100	12-14	93101-10001
16-18	91401-20015	13- 8	92901-04100	7- 6	93101-12004
6- 5	91401-25017	13-12	92901-04100	24- 7	93102-18008
16- 3	91401-30020	13-16	92901-04100	3-21	93102-20009
16-16	91501-08038	13- 9	92901-04200	5-25	93102-25017
2- 4	91810-03014	6-15	92901-05100	3-16	93103-28012
2-12	91810-03014	12-12	92901-05100	23- 4	93106-20001
1- 3	91810-08016	15- 8	92901-05100	24- 4	93106-20002
11- 7	91903-06010	11- 4	92901-06100	23- 6	93107-42001
17-20	91501-06010	14- 8	92901-06100	4-17	93108-15001
17-23	91501-06010	18-12	92901-06100	8- 9	93109-15001
23- 7	92501-06010	23-15	92901-06100	1-23	93210-12014
5- 9	92501-06012	24-14	92901-06100	1-22	93210-23029
25- 5	92501-06012	24-29	92901-06100	23- 3	93306-20203
1-25	92501-06015	25- 4	92901-06100	5- 7	93306-20301
2-19	92501-06018	25- 6	92901-06100	3-20	93306-20408
1- 4	92501-06030	1-16	92901-06200	24- 3	93306-30101
2-13	92501-06030	14- 9	92901-06200	3-11	93306-30302
2- 9	92501-06040	16- 9	92901-06200	5-24	93306-30305
2-14	92501-06040	17-21	92901-06200	3- 6	93310-11202

NUMERICAL INDEX

Ref No.	Parts No.	Ref No.	Parts No.	Ref No.	Parts No.
3- 4	93310-41810	10- 9	98501-04010		
5- 6	93410-13004	10-29	98501-04010		
5-18	93410-13004	25- 8	98501-05005		
5-23	93410-13004	15- 7	98501-05008		
8-10	93410-15005	6-14	98501-05012		
8-14	93410-25017	12- 9	98501-05015		
6-12	93430-03014	19-14	98501-05018		
6- 6	93430-08006	19-20	98501-05018		
7- 8	93430-10016	13-17	98701-05015		
12- 8	93440-08001	7- 5	98800-08100		
6- 9	93440-32017	19-21	98801-05100		
4-18	93501-04004	12-13	98801-05200		
4-14	93503-16003	14-13	98801-08100		
18- 3	93503-16003	16-13	98801-08300		
12-17	93505-32002	24-19	98801-08300		
3-12	93603-08067	24-39	98801-08300		
12- 3	93603-22028	3-24	98801-12200		
1-24	93604-14012	12-21	98901-04008		
6-10	93604-22050				
23-20	94125-15091				
24-31	94125-15091				
23-21	94225-15036				
24-32	94225-15036				
23-22	94325-15028				
24-33	94325-15028				
23-23	94414-15058				
24-34	94414-15058				
24-40	94504-20090				
24-41	94604-20001				
25-11	94700-00040				
11-11	97201-08012				
14-10	97201-08030				
14- 3	97201-08090				
14-11	97201-08100				
14-12	97201-08115				
2- 7	98501-04008				
9- 5	98501-04008				
20- 3	98501-04008				



OIL PUMP

Ref. No.	Part No.	Description	Qty	Applicable Machine No.	Remarks
12-24	257-13161-00	. PIPE, delivery	1		
12-25	214-13164-00	. CLIP, delivery pipe	2		
12-26	137-13165-00	BOLT, banjo	1		
12-27	137-13167-00	GASKET, banjo	2		

PUT THIS PAGE IN THE PLACE OF JT1 PARTS LIST.

Fig. 13 FLYWHEEL MAGNETO

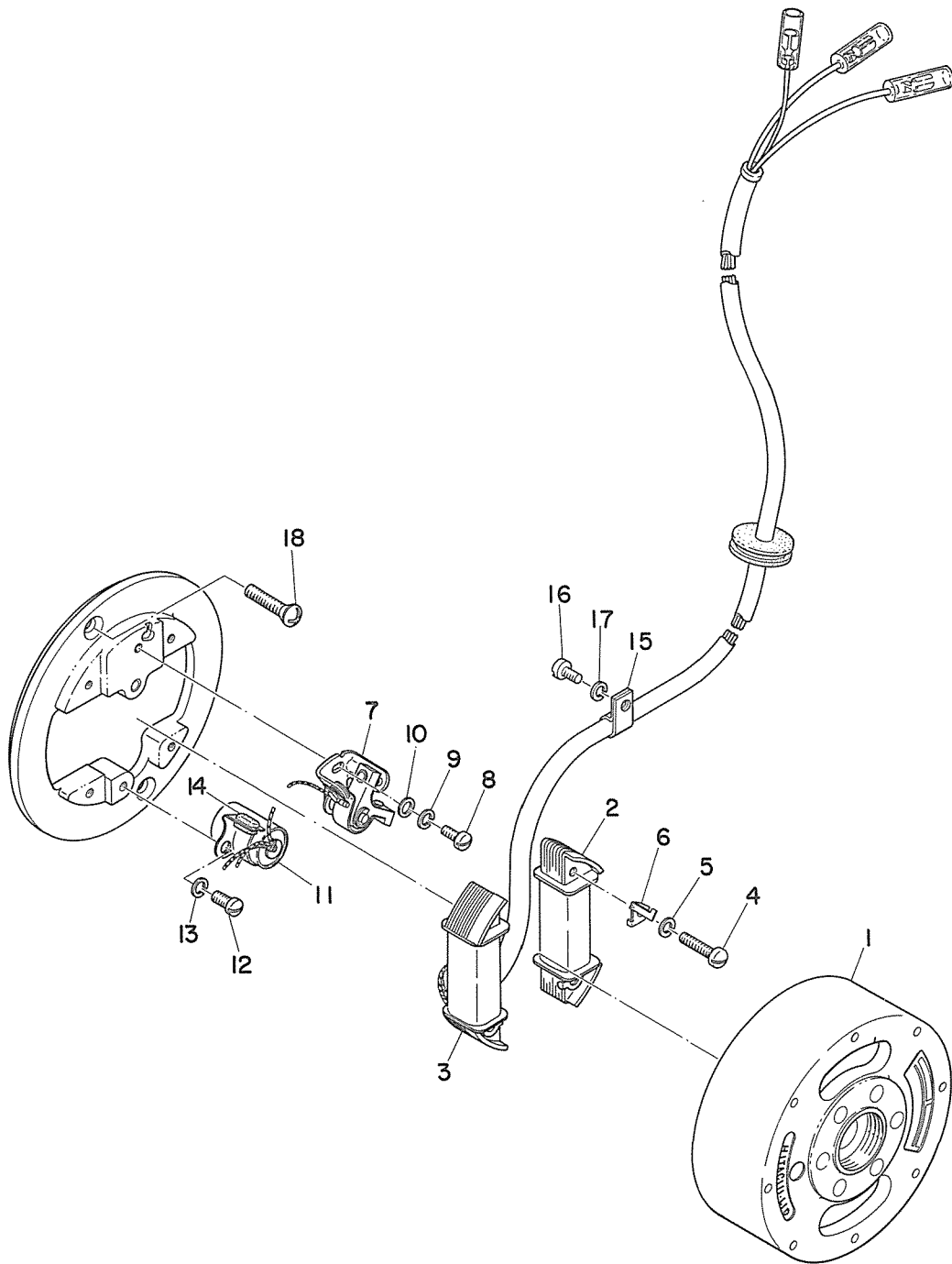

FLYWHEEL MAGNETO

Ref. No.	Part. No.	Description	Q'ty	Applicable Machine No.	Remarks
13- 0-1	288-81300-10	FLYWHEEL MAGNETO ASS'Y	1		
	288-81300-11	FLYWHEEL MAGNETO ASS'Y	1		
13- 1	207-81350-10	. ROTOR ASS'Y	1		
13- 2	207-81312-10	. COIL, source	1		
13- 3	288-81313-11	. COIL, lighting	1		
13- 4	110-81348-20	. SCREW, pan head	4		
13- 5	92901-04100	. WASHER, spring	4		
13- 6	257-81332-10	. PLATE, timing	1		
13- 7	207-81321-10	. CONTACT BREAKER ASS'Y	1		
13- 8	110-81347-20	. SCREW, pan head	1		
13- 9	92901-04100	. WASHER, spring	1		
13-10	92901-04200	. WASHER, plain	1		
13-11	207-81326-10	. CONDENSER	1		
13-12	110-81346-20	. SCREW, pan head	1		
13-13	92901-04100	. WASHER, spring	1		
13-14	207-81331-10	. LUBRICATOR	1		
13-15	109-81328-10	. CLAMP, lead	1		
13-16	165-81145-21	. SCREW, pan head (4-8)	1		
13-17	92901-04100	. WASHER, spring	1		
13-18	98701-05015	SCREW, flat head	2		

PUT THIS PAGE IN THE PLACE OF JT1 PARTS LIST.





Fig. 26 HEAD LAMP & TAIL LAMP (JT1L)

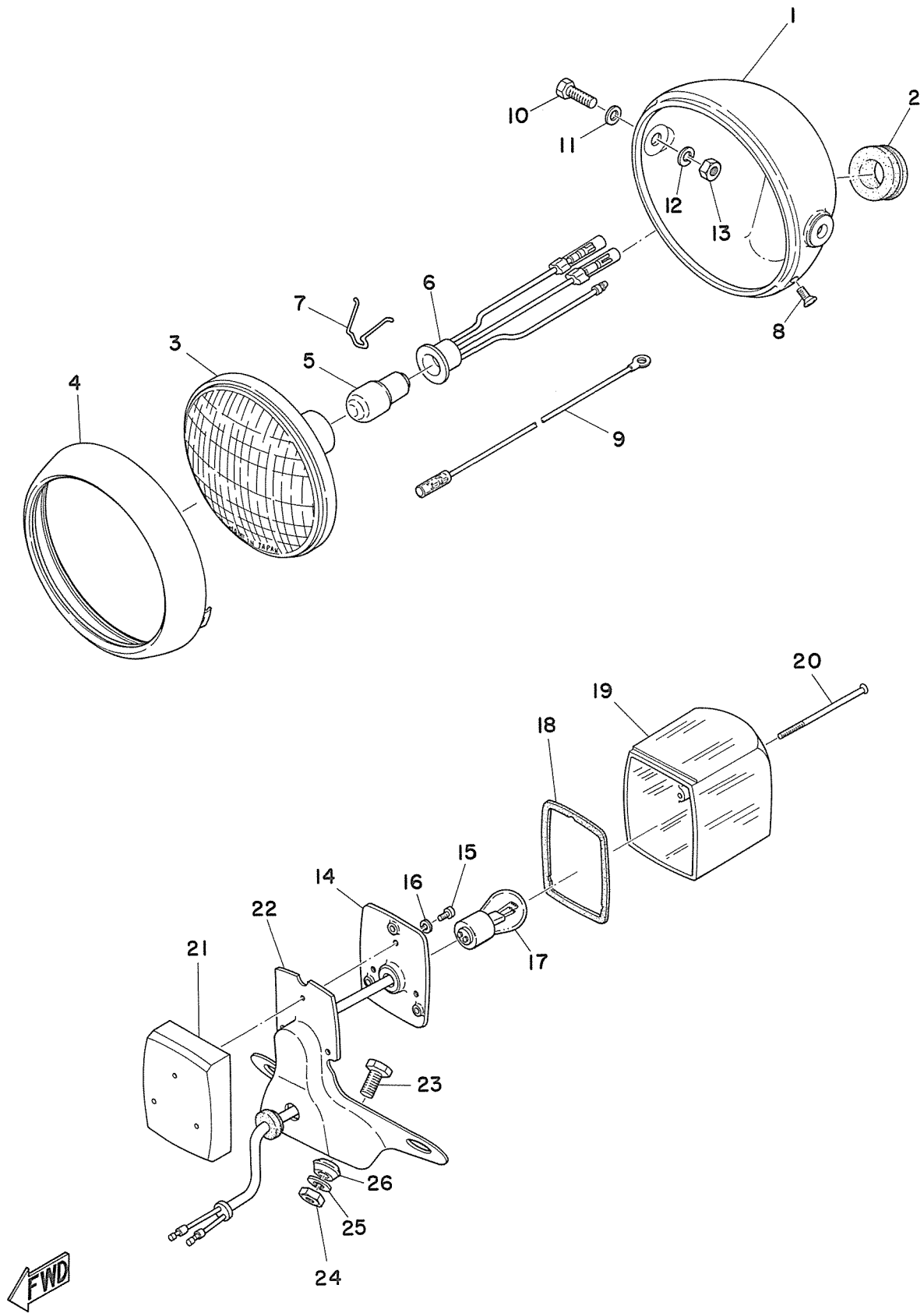
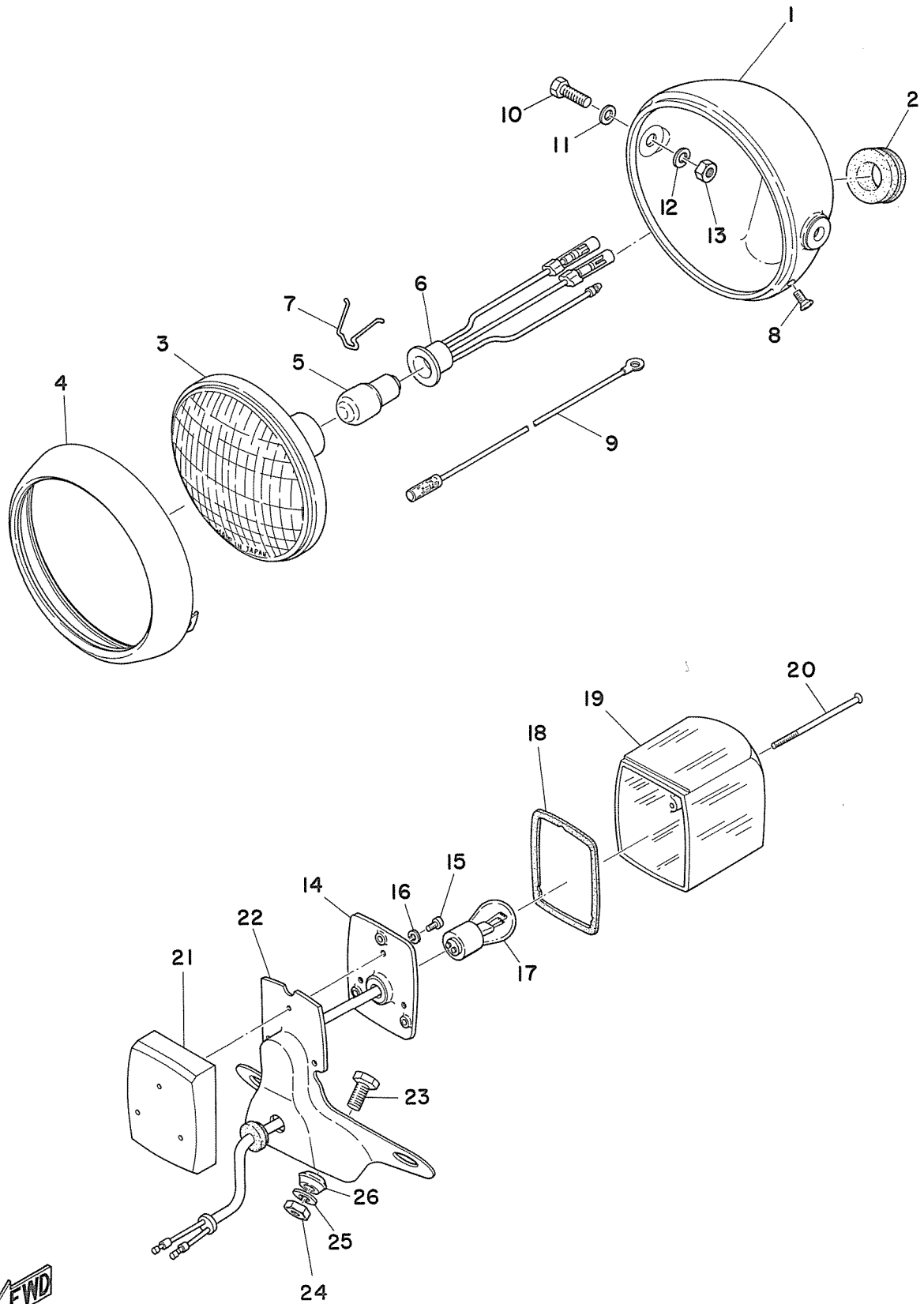

Fig. 26 HEAD LAMP & TAIL LAMP (JT1L)

Ref. No.	Parts No.	Description	Q'ty	Applicable Machine No.	Remarks
26- 1	241-84330-00-74	BODY ASS'Y	1		
26- 2	150-84153-00	. GROMMET	1		
26- 0-1	288-84110-60	HEAD LAMP UNIT ASS'Y	1		
26- 3	288-84120-60	. LENS ASSY	1		
26- 4	195-84315-01	. RIM, head lamp	1		
26- 5	104-84114-00	. BULB (6V 15W/15W)	1		
26- 6	241-84312-00	. SOCKET	1		
26- 7	195-84324-00	. SPRING, reflector set	3		
26- 8	195-84325-00	SCREW, rim fitting	1		
26- 9	173-84313-00	WIRE, earth	1		
26-10	97203-08020	BOLT	2		
26-11	92903-08200	WASHER, plain	2		
26-12	92901-08100	WASHER, spring	2		
26-13	98801-08100	NUT	2		
26- 0-2	288-84510-60	TAIL LAMP UNIT ASS'Y	1		
26-14	290-84511-00	. BASE	1		
26-15	98501-04010	. SCREW, pan head	3		
26-16	92901-04100	. WASHER, spring	3		
26-17	122-84514-00	. BULB, tail lamp (6V 10/3W)	1		
26-18	164-84723-00	. GASKET	1		
26-19	288-84521-09	. LENS, tail lamp	1		
26-20	201-84724-00	. SCREW, lens fitting	3		
26-21	201-84716-00	. COVER, tail lamp	1		
26-22	288-84551-09-35	BRACKET, license	1		

Fig. 26 HEAD LAMP & TAIL LAMP (JT1L)



HEAD LAMP & TAIL LAMP (JT1L)

Ref. No.	Parts No.	Description	Q'ty	Applicable Machine No.	Remarks
26-23	91201-06012	BOLT	2		
26-24	92801-06100	NUT	2		
26-25	92901-06100	WASHER, spring	2		
26-26	152-84518-00	GROMMET	2		

Fig. 27 ELECTRICAL (JT1L)

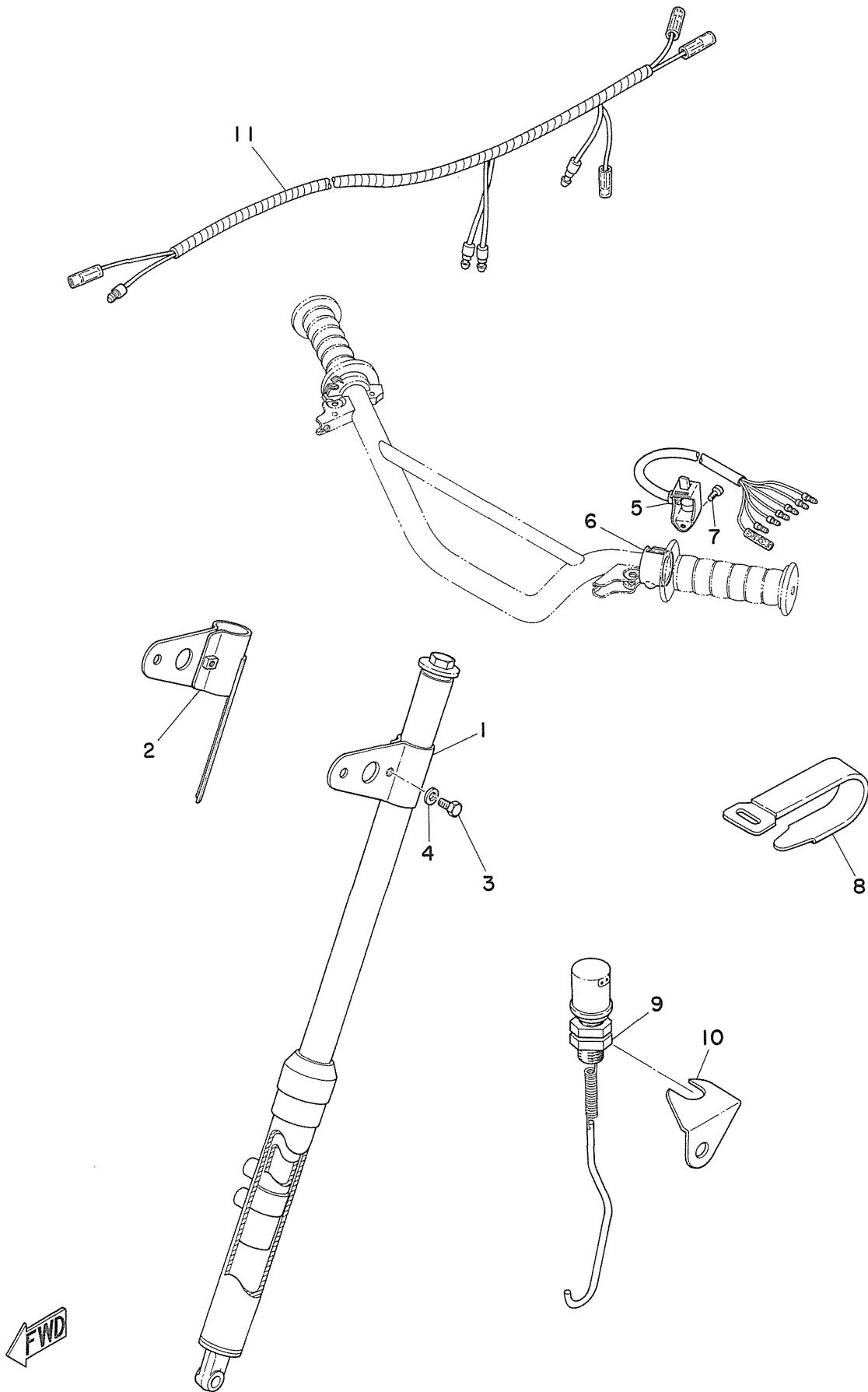

ELECTRICAL (JT1L)

Ref. No.	Parts No.	Description	Q'ty	Applicable Machine No.	Remarks
27- 1	290-84118-01	STAY, head lamp left	1		
27- 2	290-84119-01	STAY, head lamp right	1		
27- 3	91203-06015	BOLT	2		
27- 4	92901-06200	WASHER, plain	2		
27- 5	288-83973-00	SWITCH, handle 3	1		
27- 6	214-83974-00	HOLDER, handle switch	1		
27- 7	98503-05015	SCREW, pan head	1		
27- 8	168-83936-01	BAND, switch cord	1		
27- 9	290-83530-00	STOP SWITCH ASS'Y	1		
27-10	290-83539-00	STAY, stop switch	1		
27-11	288-82590-20	WIRE HARNESS ASS'Y	1		

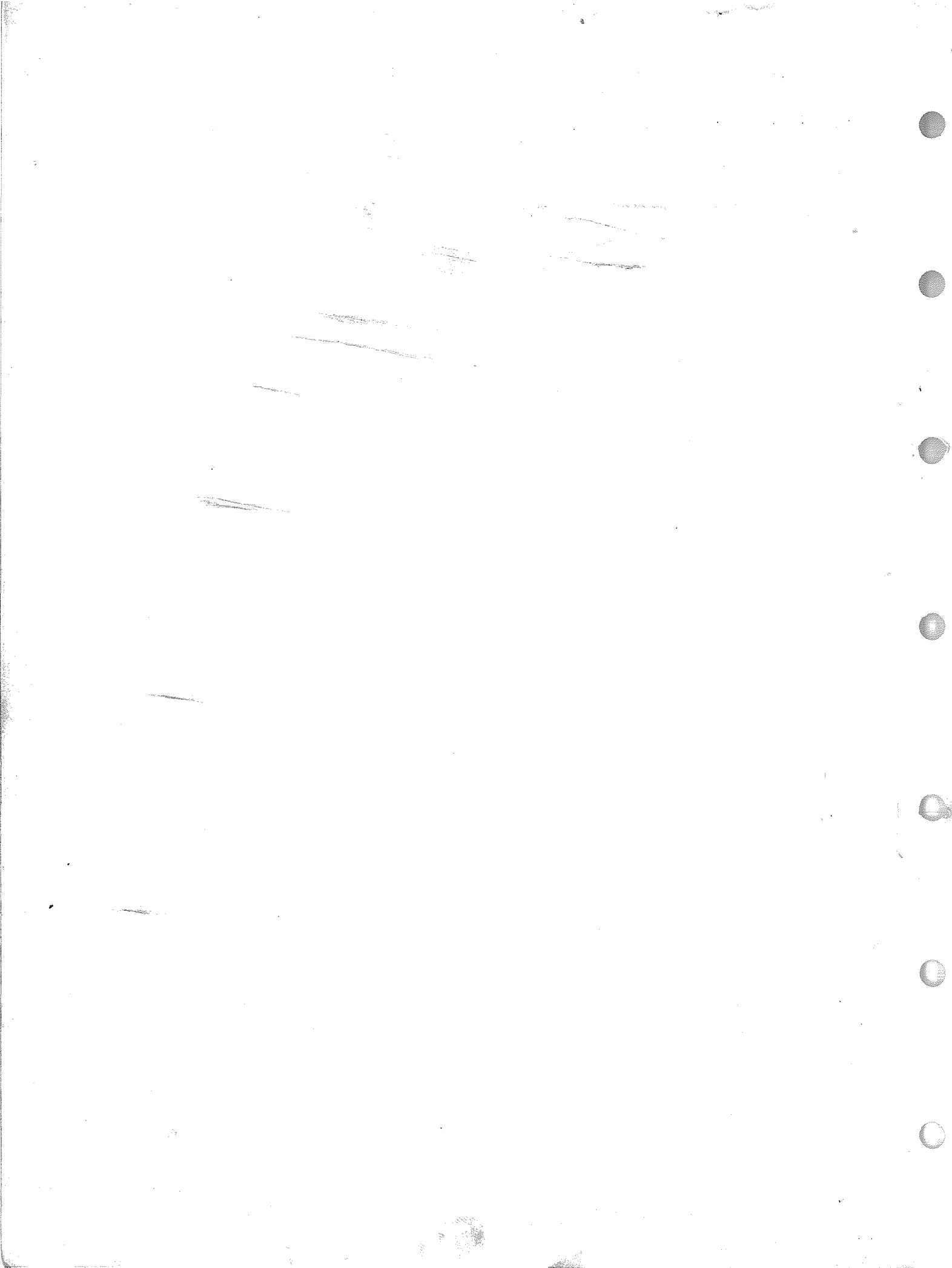



YAMAHA MOTOR CO., LTD.

PRINTED IN JAPAN

First edition June, 1970